

Work support

7 MPa

Hydraulic lift,
support force enhanced model
model CSU-H10-L



Hydraulic lift,
standard model
model CSU10-L



Spring lift
model CST10-L



Hydraulic lift,
support force enhanced model
model CSY03-L



Hydraulic lift,
standard model
model CSN03-L



Spring lift
model CSK03-L



Hydraulic lift

Standard model **CSU**□-□□

Support force enhanced model **CSU-H**□-□□



Work support

CSU Hydraulic lift

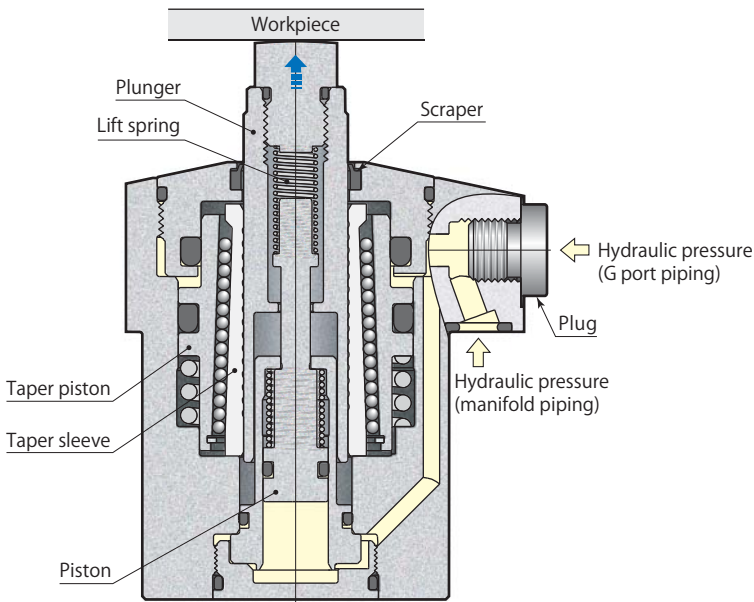

Lock

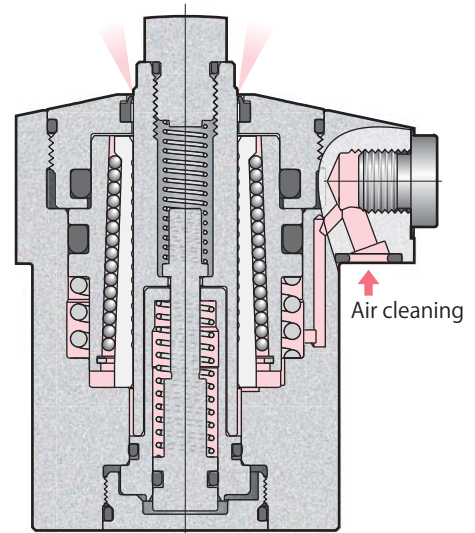

Unlock

Hydraulic and pneumatic circuit diagram

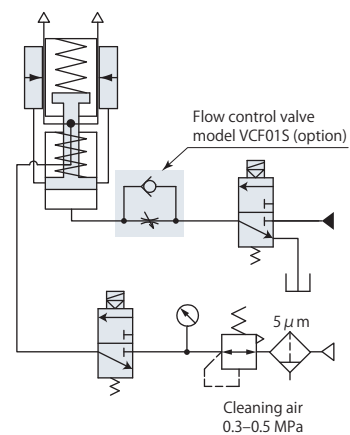

Specifications	page → 110
Hydraulic pressure & support force	page → 111
Applied load & deformation	page → 111
Dimensions	page → 112
Mounting details	page → 112
Air sensor	page → 114

Spring lift

model CST □-□

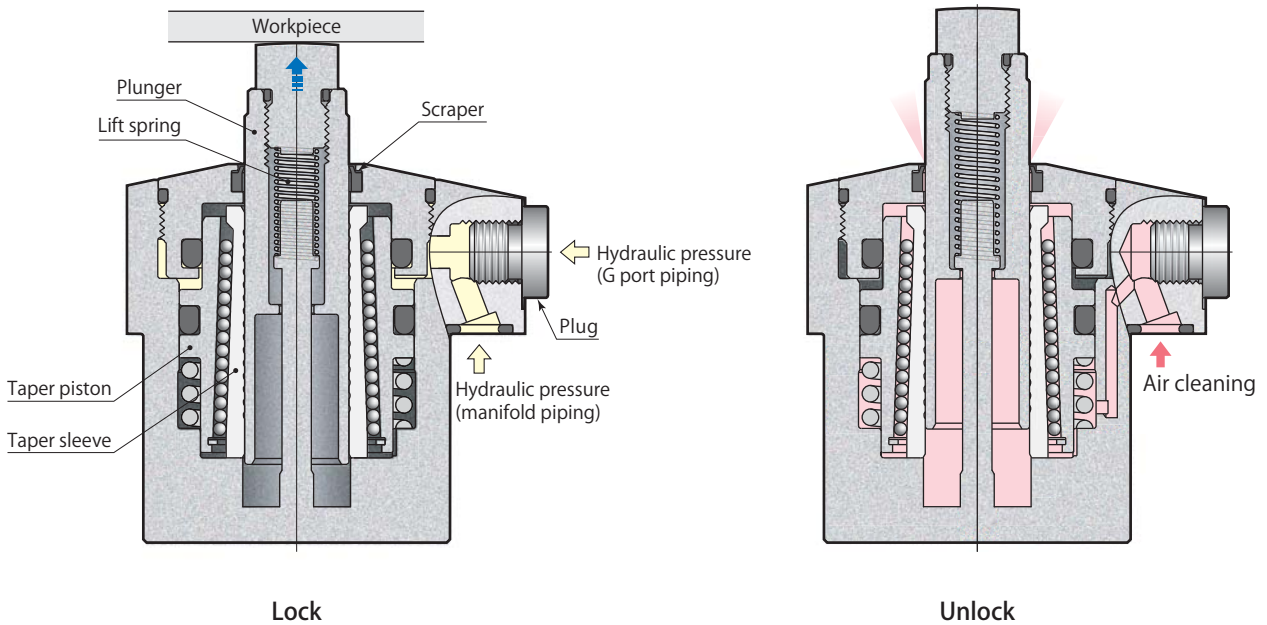

Work support
CST Spring lift

Hydraulic and pneumatic circuit diagram

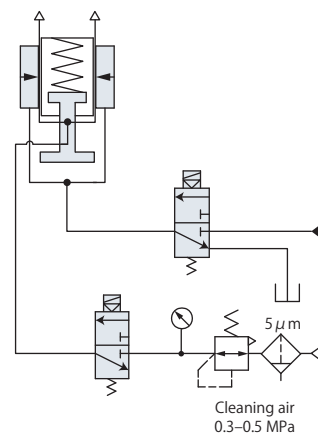

- Specifications page → 110
- Hydraulic pressure & support force page → 111
- Applied load & deformation page → 111
- Dimensions page → 118
- Mounting details page → 118

Hydraulic lift (model CSU)

Plunger is locked after it stroked by the structure containing sequential movement, which enables a workpiece to hold securely.

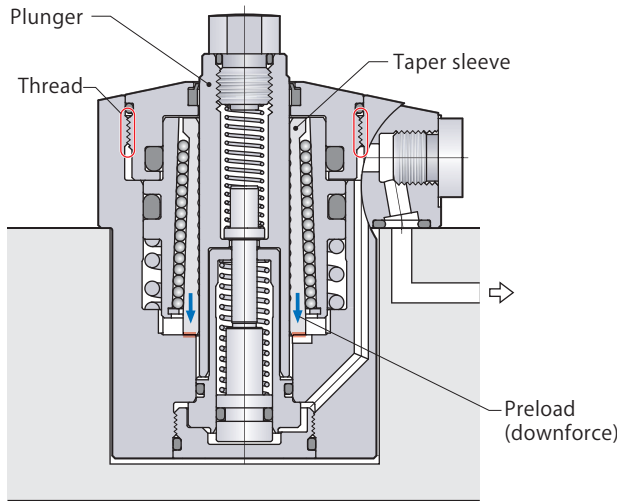

- The taper sleeve is preloaded by the thread and is kept the position lower.

① The piston moves upward

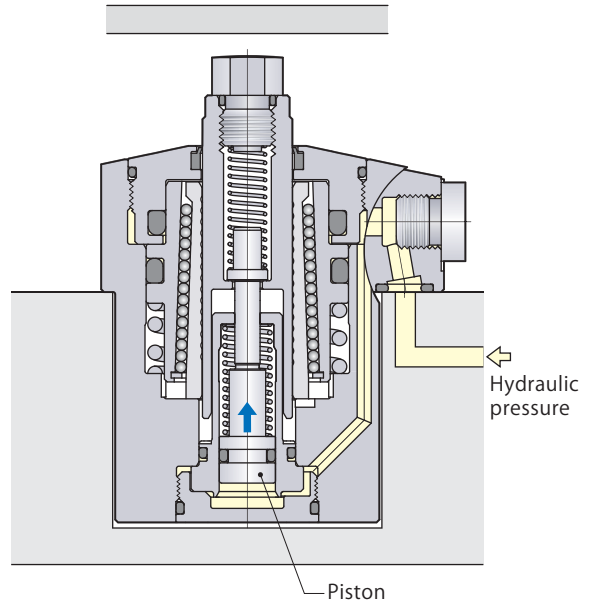

- Piston moves upward by the hydraulic force.

Spring lift (model CST)

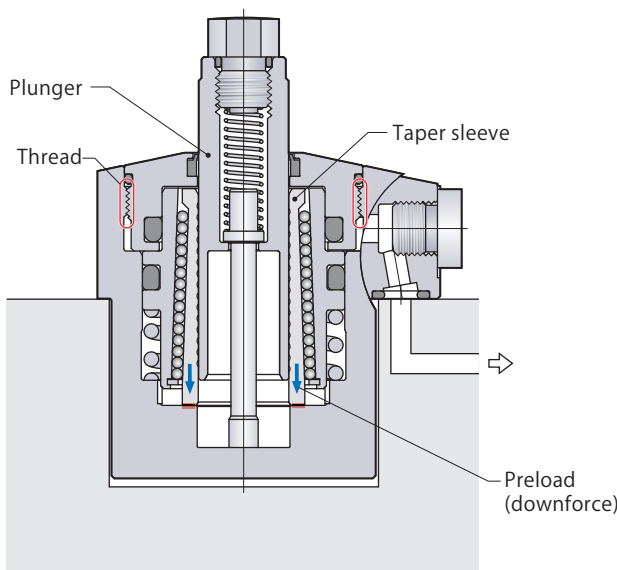

- The taper sleeve is preloaded by the thread and is kept the position lower.

① Before the workpiece approaches

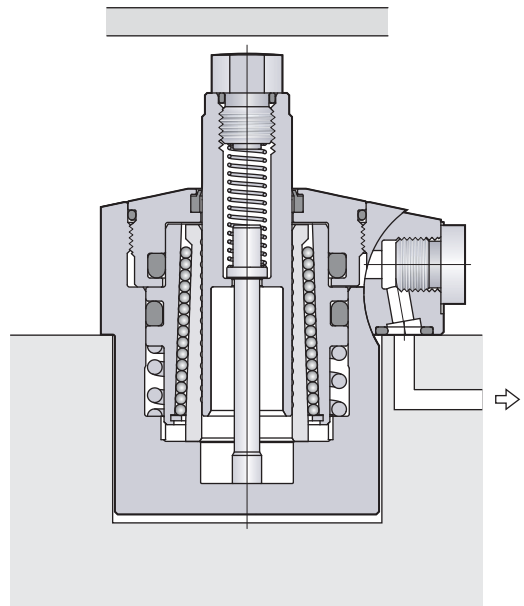

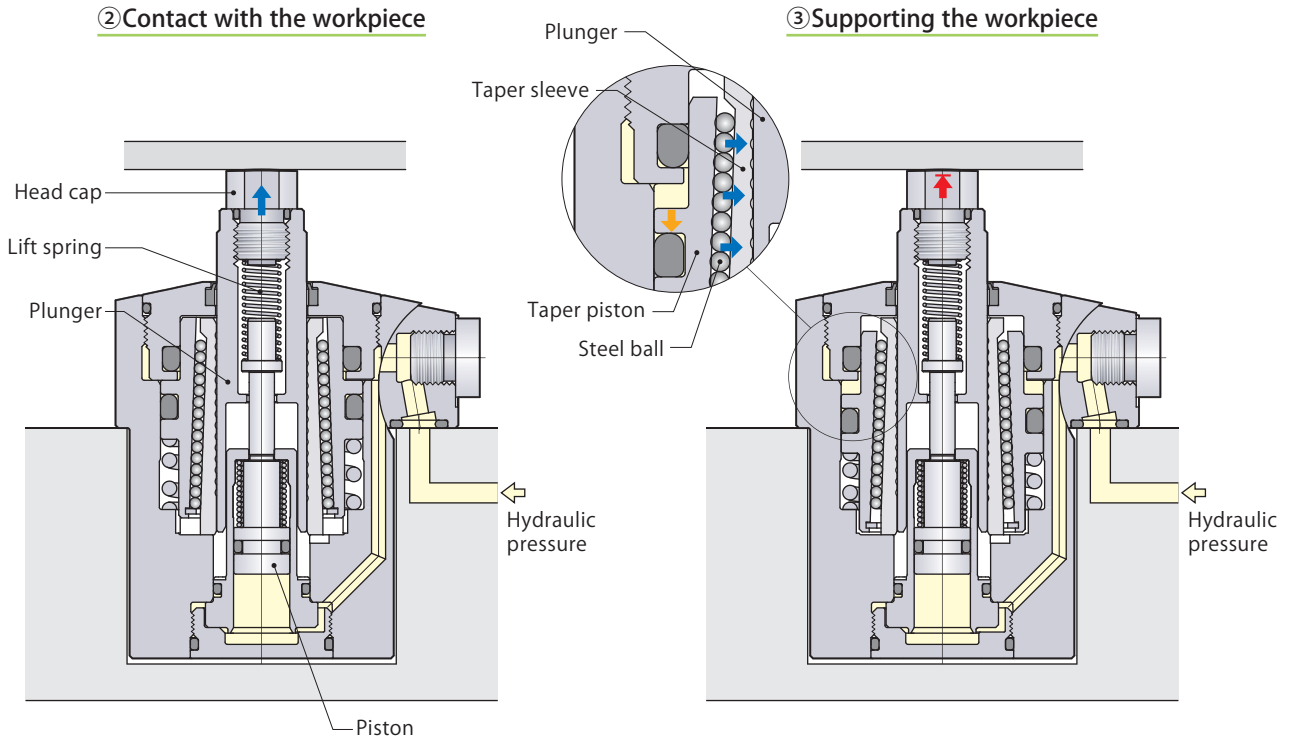

- The plunger with a head cap strokes upward by the lift spring to contact the workpiece. The plunger puts a load on the workpiece since the piston continues to move upward to the end of its stroke.

- After piston stroking, the taper piston moves down by the hydraulic force to depress the taper sleeve by means of the steel balls. Then the taper sleeve locks the plunger firmly.

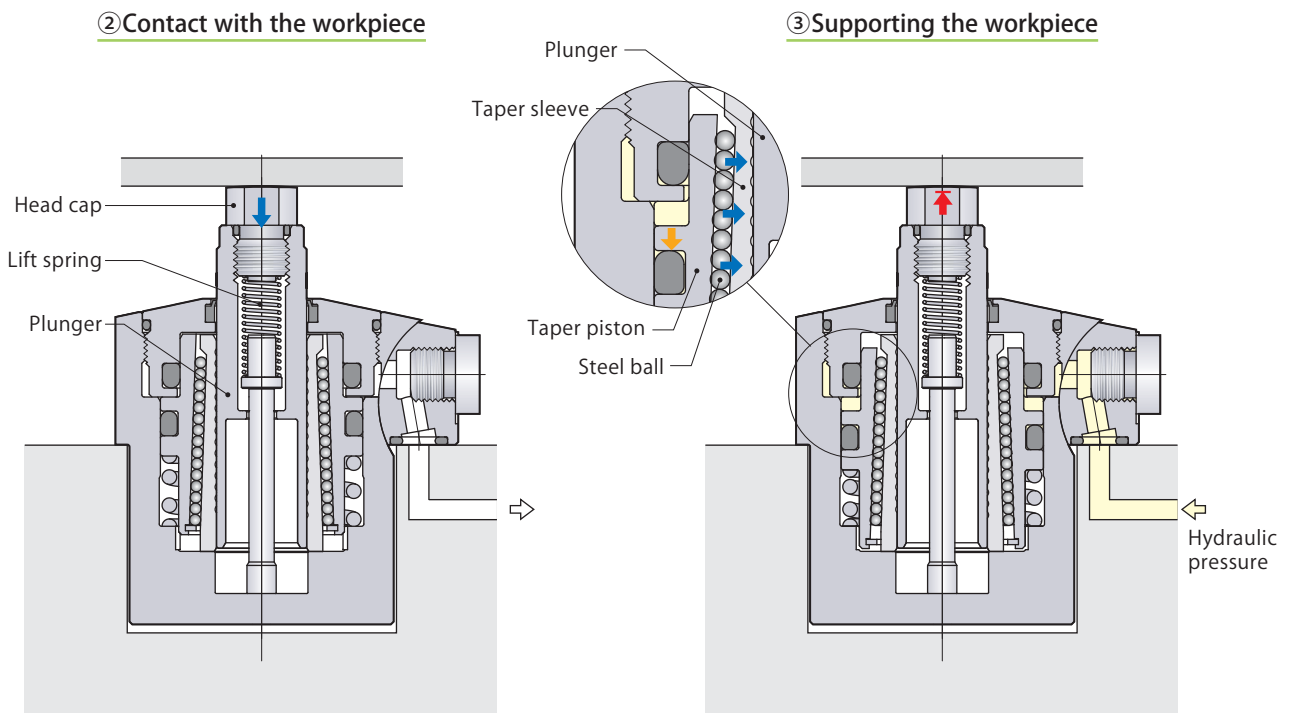

- The workpiece touches head cap then depresses the plunger until it reaches to the seating surface. The lift spring puts a load onto the workpiece.

- The taper piston is pushed down by the hydraulic force to depress the taper sleeve by means of the steel balls. Then the taper sleeve locks the plunger firmly.

Specifications

	Size	Lift spring force	
CSU : Hydraulic lift, standard	04		
	06	L : Standard	(Nil) : Standard
CSU-H : Hydraulic lift, support force enhanced	10 —		B : Air sensor
	16	H : Strong	
CST : Spring lift	25		
			■ indicates made to order.

Air sensor is not applicable for CSU-H, also force exchanged type or air sensor is not available for CST.

Model		CSU□04	CSU□06	CSU□10	CSU□16	CSU□25		
		CST04	CST06	CST10	CST16	CST25		
Support force (hydraulic pressure 7MPa)*1	Standard	kN	5	7	10	16	25	
	Support force enhanced	kN	7	10	14	23	36	
Cylinder capacity	CSU	cm ³	1.2	1.8	2.6	3.9	5.7	
	CST	cm ³	0.7	0.9	1.2	2.1	3.3	
Lift spring force*2	L:Standard	Standard	N	3.0–4.1	4.3–8.1	5.3–10.8	5.5–10.8	6.9–13.2
		Support force enhanced	N	4.5–6.0	5.0–11.0	8.0–17.0	9.0–17.0	11.0–20.0
	H:Strong	Standard	N	4.8–7.5	6.6–11.1	7.8–13.3	11.2–19.8	13.5–22.4
		Support force enhanced	N	6.0–9.5	8.0–14.0	11.0–20.0	11.0–21.0	20.0–25.0
Plunger stroke		mm	8	12	12	16	16	
Max. allowable mass of head cap		kg	0.15	0.2	0.2	0.3	0.3	
Mass	CSU	kg	0.6	1.0	1.2	2.0	3.3	
	CST	kg	0.5	0.9	1.1	1.8	3.1	
Recommended tightening torque of mounting screws*3		N·m	7	7	7	12	29	

- Pressure range: 2.5–7 MPa ● Proof pressure: 10.5 MPa ● Operating temperature: 0–70 °C
- Fluid used: General mineral based hydraulic oil (ISO-VG32 equivalent)
- Seals are resistant to chlorine-based cutting fluid. (not thermal resistant specification)

*1: When work support and clamp are used facing each other, work support and clamp must be selected in such a way that the support force is 1.5 times the applied load (clamping force + machining force).

*2: Figures are for “upper end to lower end” of plunger action. *3: ISO R898 class 12.9

Manifold piping and G port piping are available.

Manifold piping

When choosing manifold piping, a flow control valve (model VCF) and an air bleeding valve (model VCE) are mountable on the G ports of the clamp.

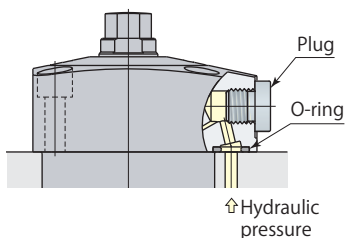

G port piping

Remove plugs when choosing G port piping. (O-ring must be used.) Refer to **page →150** for details on G port piping flareless fitting. The flow control valve and the air bleeding valve should be installed in the middle of oil path.

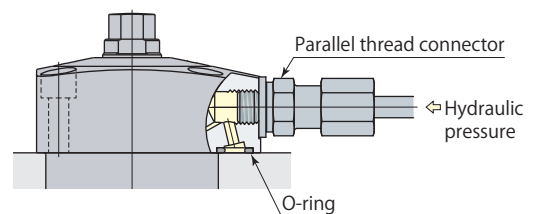

Hydraulic pressure & support force

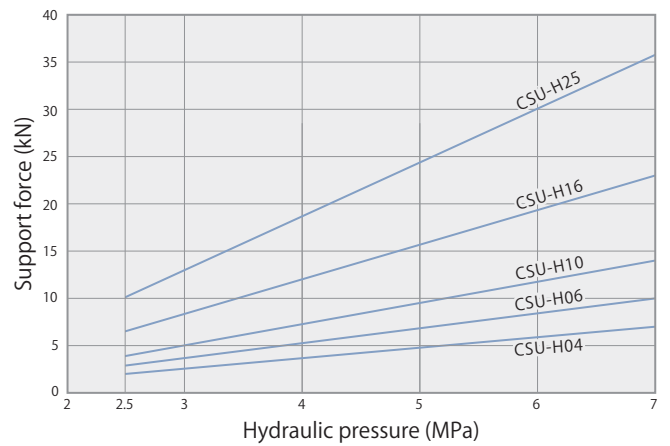
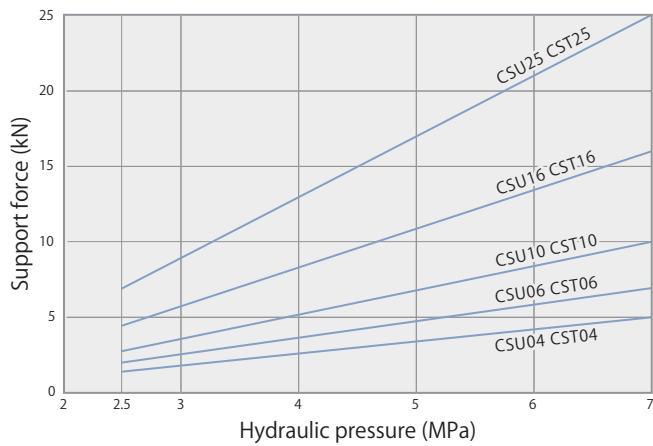

Hydraulic pressure MPa	Support force kN				
	CSU04 CST04	CSU06 CST06	CSU10 CST10	CSU16 CST16	CSU25 CST25
2.5	1.4	2.0	2.8	4.5	7.0
3.0	1.8	2.6	3.6	5.8	9.0
3.5	2.2	3.1	4.4	7.1	11.0
4.0	2.6	3.7	5.2	8.3	13.0
4.5	3.0	4.2	6.0	9.6	15.0
5.0	3.4	4.8	6.8	10.9	17.0
5.5	3.8	5.3	7.6	12.2	19.0
6.0	4.2	5.9	8.4	13.4	21.0
6.5	4.6	6.4	9.2	14.7	23.0
7.0	5.0	7.0	10.0	16.0	25.0

Hydraulic pressure MPa	Support force kN				
	CSU-H04	CSU-H06	CSU-H10	CSU-H16	CSU-H25
2.5	2.0	2.9	3.9	6.5	10.1
3.0	2.6	3.7	5.0	8.3	13.0
3.5	3.1	4.5	6.1	10.2	15.9
4.0	3.7	5.3	7.3	12.0	18.7
4.5	4.2	6.1	8.4	13.8	21.6
5.0	4.8	6.9	9.5	15.7	24.5
5.5	5.3	7.6	10.6	17.5	27.4
6.0	5.9	8.4	11.7	19.3	30.2
6.5	6.4	9.2	12.9	21.2	33.1
7.0	7.0	10.0	14.0	23.0	36.0

Applied load & deformation

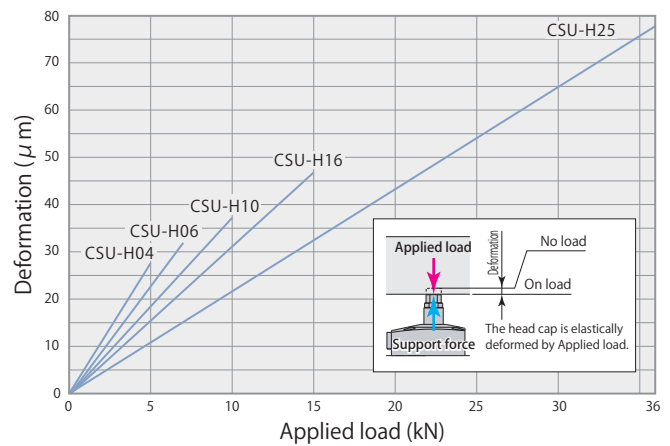
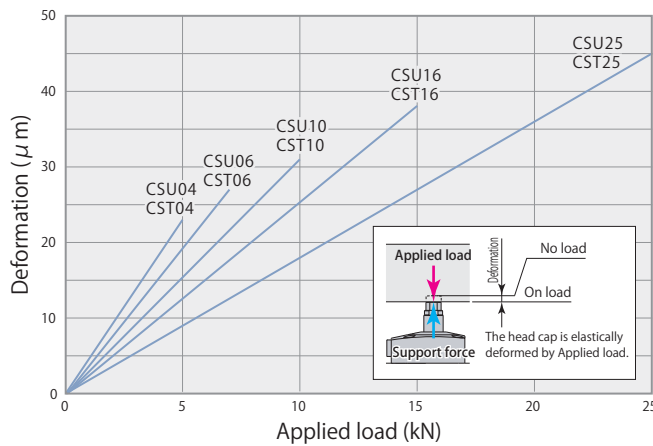

Applied load kN	Deformation μm				
	CSU04 CST04	CSU06 CST06	CSU10 CST10	CSU16 CST16	CSU25 CST25
0	0	0	0	0	0
5	23	19	16	13	9
7		27	22	18	13
10			31	26	18
15				38	27
20			Nonusable range		36
25					45

Applied load kN	Deformation μm				
	CSU-H04	CSU-H06	CSU-H10	CSU-H16	CSU-H25
0	0	0	0	0	0
5	27.6	22.8	18.6	15.6	10.8
7		31.9	26	21.8	15.1
10			37.2	31.2	21.6
15				46.8	32.4
20			Nonusable range		43.2
25					54
36					77.8

Held with hydraulic pressure of 7 MPa.

Held with hydraulic pressure of 7 MPa.

Dimensions

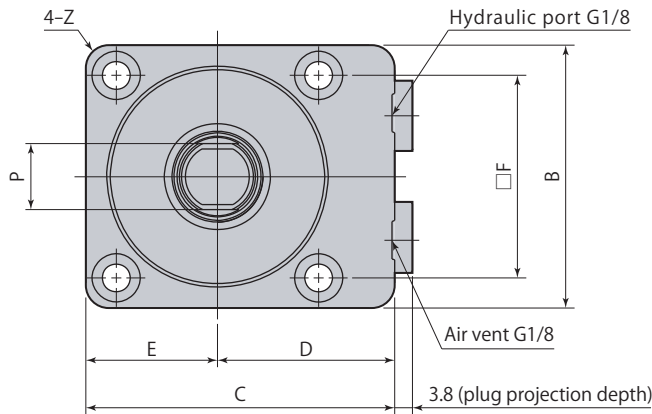

Mounting details

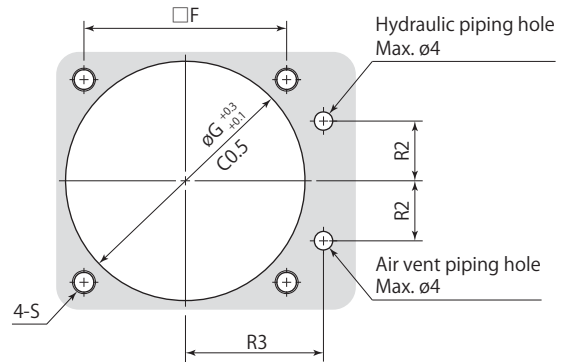

Plunger tip section details

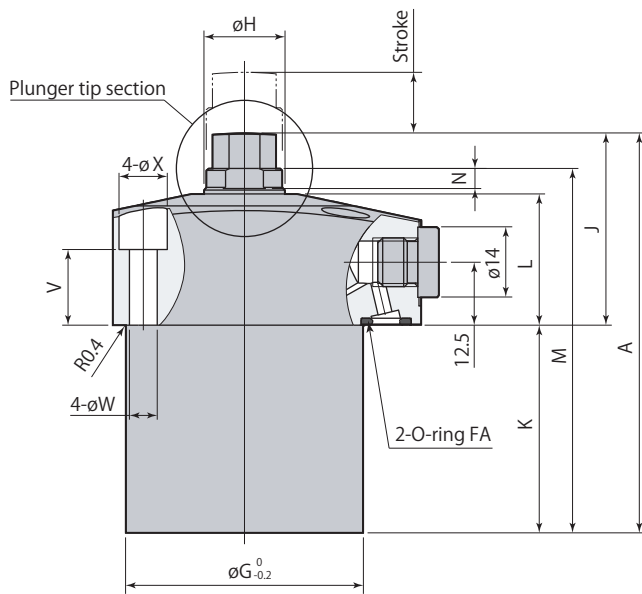
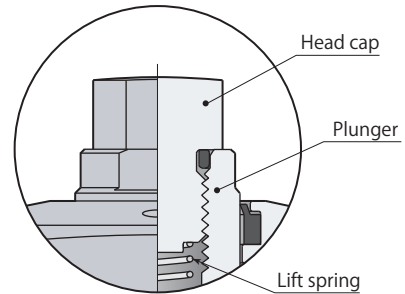

Head cap details

Hardness: HRC52

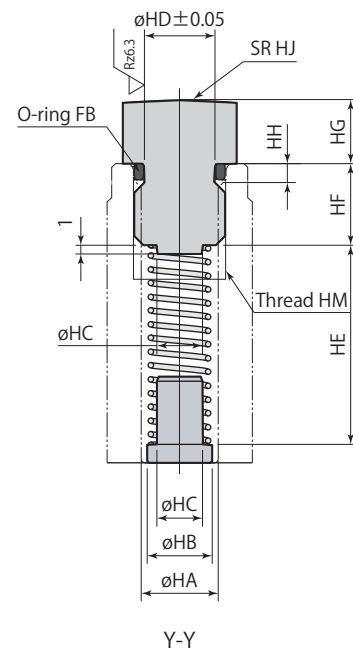
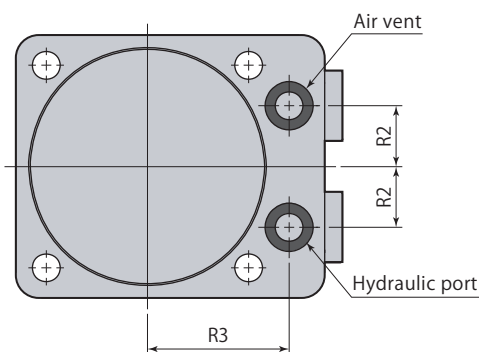
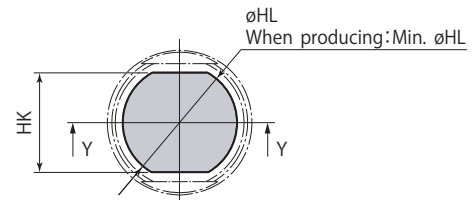

Y-Y

Work support

CSU Hydraulic lift

Model	CSU□04-□	CSU□06-□	CSU□10-□	CSU□16-□	CSU□25-□
A	68	79	82	102	122
B	45	52	56	65	78
C	55	61	65	73	85
D	32.5	35	37	40.5	46
E	22.5	26	28	32.5	39
F	34	40	44	52	62
øG	40	47	52	60	72
øH	15	16	20	22	25
J	38	38	40	45	46
K	30	41	42	57	76
L	26	26	28	30	30
M	61	72	75	93	113
N (width across flats height)	4	4	4.5	5	6
P (width across flats)	13	13	17	19	22
R2	10	12	13	15	18
R3	25.5	28	30	33.5	39
S	M5	M5	M5	M6	M8
V	15	15	16.5	15.9	12
W	5.5	5.5	5.5	6.8	9
X	9.5	9.5	9.5	11	14
Z	R3	R5	R5	R6	R7
O-ring FA (fluorocarbon hardness Hs90)	P7	P7	P7	P7	P7
Flow control valve (meter-in)	VCF01S	VCF01S	VCF01S	VCF01S	VCF01S
Air bleeding valve	VCE01	VCE01	VCE01	VCE01	VCE01

- The mounting surface finish must be no rougher than Rz6.3 (ISO4287:1997).
- Always attach head cap (lift spring cannot be retained).
- Mounting screws are not included.

Head cap details

Model	CSU□04-□	CSU□06-□	CSU□10-□	CSU□16-□	CSU□25-□
øHA	8.5	8.5	10.3	10.3	14
øHB	7.2	7.2	9.2	9.2	11.2
øHC	5	5	6	6	7.5
øHD	7.8	7.8	9.2	9.2	13.5
HE	17.6	22	22.5	32.5	39
HF	9	9	11	11	15
HG	7	7	7	9	9
HH	1.9	1.9	2.3	2.3	3.5
HJ	70	70	90	110	140
HK	11	11	14	14	18
øHL	12.6	12.6	16.5	16.5	21.5
Min. øHL	12.5	12.5	16.5	16.5	21.5
HM (recommended tightening torque)	M10×1.5 depth 11 (30 N·m)	M10×1.5 depth 11 (30 N·m)	M12×1.75 depth 13 (50 N·m)	M12×1.75 depth 13 (50 N·m)	M16×2 depth 20 (80 N·m)
O-ring FB (fluorocarbon hardness Hs70)	S8	S8	P9	P9	AS568-014

- When fabricating head cap, ensure that O-ring slot, spring spot facing and guide are made by referring to head cap details. Be sure to always use included O-ring.
- When fabricating a lift spring, determine dimensions by referring to head cap details. Furthermore, rustproofing must be implemented (however, there is no guarantee for operation).
- This diagram indicates a situation where head cap has been fitted into plunger with no pressure applied.

Air sensor

Supplier and model	ISA3-G series manufactured by SMC GPS2-05, GPS3-E series manufactured by CKD
Air supply pressure	0.1 MPa
Inner diameter of piping	ø4 mm
Overall piping length	5 m or less

- Air supply to air sensor unit should be provided to the air vent port. Supplied air should be dried and filtered with particulate size 5 μm or less.
- Use a solenoid valve with needle for air sensor unit and control it supplying air all the time in order to eliminate intrusion of chips or coolant.
- There is a case that air sensing cannot be successfully made as designed when it is used out of the above usage. Contact Technical service center for more details.
- Refer to the sensor supplier's instruction manual for the details of setting.
- Sensing performance such as detectable time and pressure differs depending on the supplier and model number of the sensor. Select the right model referring to sensor's application and characteristics.
- When performing workpiece contact detection for multiple workpieces (in parallel fittings) using one air sensor, consider detection range of air sensor before determining the number of workpiece contacts to be detected.
- Setting air pressure that exceeds air pressure range results in leaking of air from scraper and accurate detection will not be possible.
- If the lowering operation slows down due to air pressure, stop air supply during lowering operation.

Workpiece contact force

Workpiece contact force (lift spring + air pressure lift) is exerted onto workpiece during workpiece setting. Lift spring force varies according to the stroke used. Use following formula to obtain lift spring force:

Lift spring force calculation formula $P_s = P_1 - (P_1 - P_2) \times D_2 / D_1$

Example: model CSU06-LB using stroke of 5 mm:
Lift spring force = 8.1 - (8.1 - 4.3) × 5 / 12 = 6.5 (N)

Workpiece contact force varies according to the air pressure used. Use following formula to obtain workpiece contact force:

Workpiece contact force calculation formula $P = P_s + \eta \times P_a$

Example: model CSU06-LB using stroke of 5 mm and air pressure of 0.05 MPa,
Workpiece contact force = 6.5 + 200 × 0.05 = 16.5 (N)

P1 : Lift spring force at lower end (N) Lower end of plunger Upper end of plunger
P2 : Lift spring force at upper end (N)
D1 : Full stroke (mm)
D2 : Used stroke (mm)
P_s : Lift spring force (N)
η : Push up coefficient (refer to table below)
P_a : Air pressure (MPa)
P : Workpiece contact force (N)

The workpiece contact force varies depending on sliding resistance of scraper. Use calculated figures only as reference.

Model		CSU04-□B	CSU06-□B	CSU10-□B
Lift spring force N	L:Standard	3.0-4.1	4.3-8.1	5.3-10.8
	H:Strong	4.8-7.5	6.6-11.1	7.8-13.3
Air pressure range	MPa	0.03-0.1		
Plunger stroke	mm	8	12	12
Push up coefficient η		180	200	310

Lift spring force is shown as spring force for "upper end to lower end" of plunger action.

Air sensor & hydraulic circuit diagram

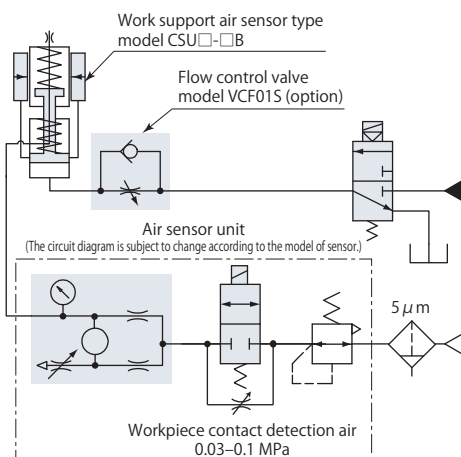

Air sensor & air cleaning & hydraulic circuit diagram

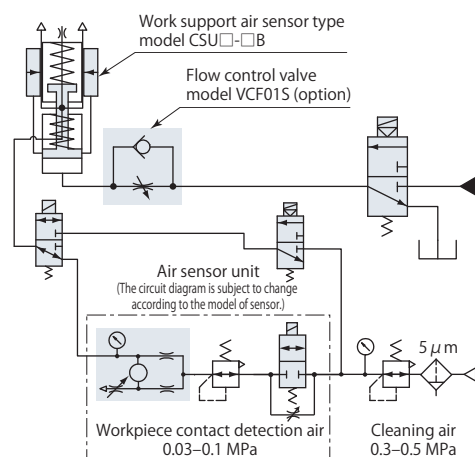

Air sensor head cap details

Hardness: HRC52

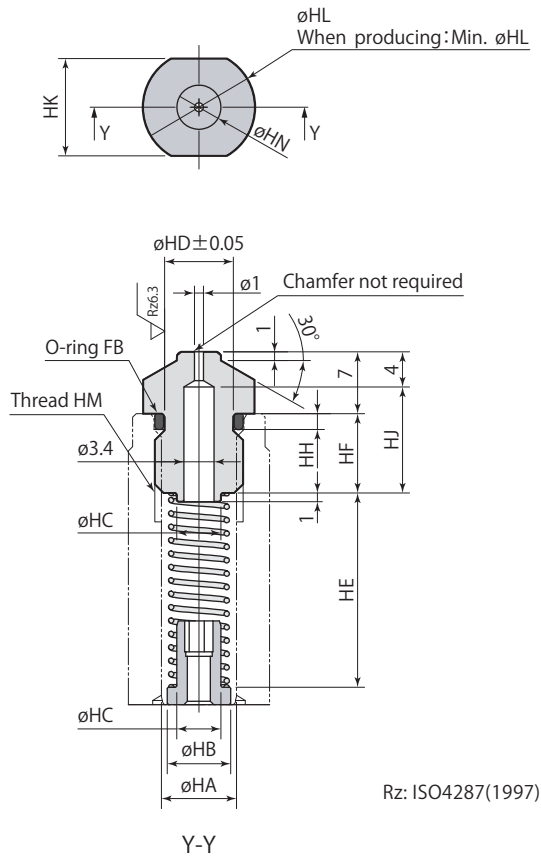

Work support
Air sensor
CSU-B
Hydraulic lift

- Workpiece contact detection is not possible merely by replacing head cap of standard work support.
- There is no air sensor available for model CSU16 or CSU25.
- This diagram indicates a situation where head cap has been fitted into plunger with no pressure applied.

Model	CSU04-□B	CSU06-□B	CSU10-□B
ϕHA	8.5	8.5	10.3
ϕHB	7.2	7.2	9.2
ϕHC	5	5	6
ϕHD	7.8	7.8	9.2
HE	17.6	22	22.5
HF	9	9	11
HH	1.9	1.9	2.3
HJ	12	12	14
HK (width across flats)	11	11	14
ϕHL	12.6	12.6	16.5
Min. ϕHL	12.5	12.5	16.5
HM (recommended tightening torque)	M10×1.5 depth 11 (30 N·m)	M10×1.5 depth 11 (30 N·m)	M12×1.75 depth 13 (50 N·m)
ϕHN	5	5	8
O-ring FB (fluorocarbon hardness Hs70)	S8	S8	P9

- CSU□-□B (Air sensor) is made to order.

Caution in use

- The lift spring in the plunger may push the workpiece upward if it is light weight and seating detection cannot be complete. Review the weight of workpiece or lift spring force and make it appropriate to seat the workpiece perfectly and acutate the work support.
- Set the plunger lifting time to 0.5 seconds or longer by adjusting the flow control valve with check valve (meter-in). Reasonable plunger ascending speed can prevent the parts from breakage also curbs plunger contact false. Use a flow control valve with cracking pressure of 0.05MPa or less, in order to shorten plunger descending speed. (Cracking pressure of optional flow control valve model VCF01S is 0.04 MPa.)

If the plunger ascends to reach a workpiece too fast, it rebounds after hitting the workpice and will create a small clearance between the two. The clearance may cause a supporting fault of the workpiece.

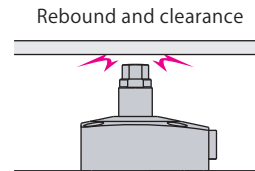

- Avoid following usages. These may cause sleeve deformation that could lead to malfunction of plunger or decreased support force.
 - ✗ Applying eccentric load on plunger.
 - ✗ Applying load that exceeds rated support force.
 - ✗ Rotating plunger when locked.
- Air vent must be opened to atmosphere. Any blockage on the vent results in malfunction. Provide the piping if there is a risk of coolant or metal chips intrusion. Allowing intrusion of cutting fluid may cause rusting and other problems.

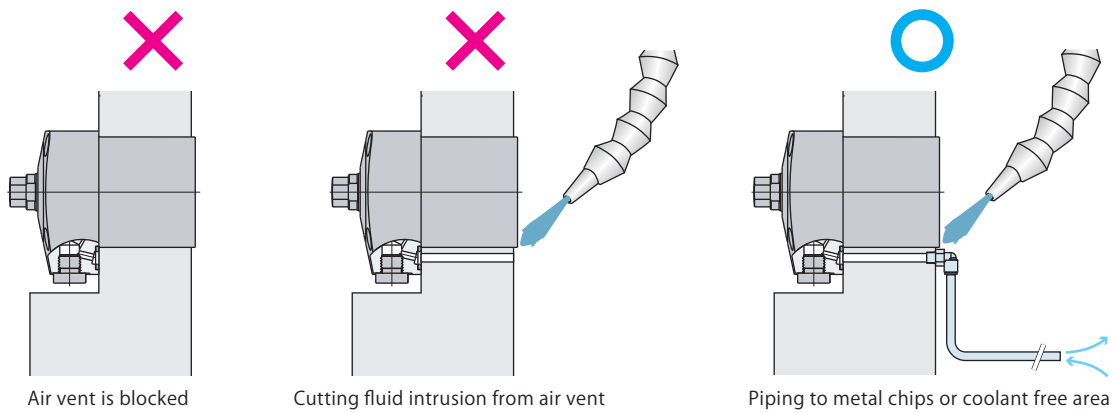

- Air (oil free) must be fed through a 5 μm filter that is connected to an air vent port for air cleaning or workpiece contact detection (air sensor). Perform air cleaning only when replacing workpiece. Plunger will rise during air cleaning.

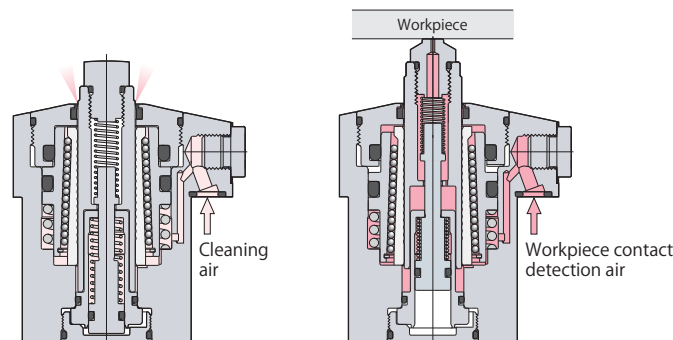

Work support

CSU Hydraulic lift

Dimensions

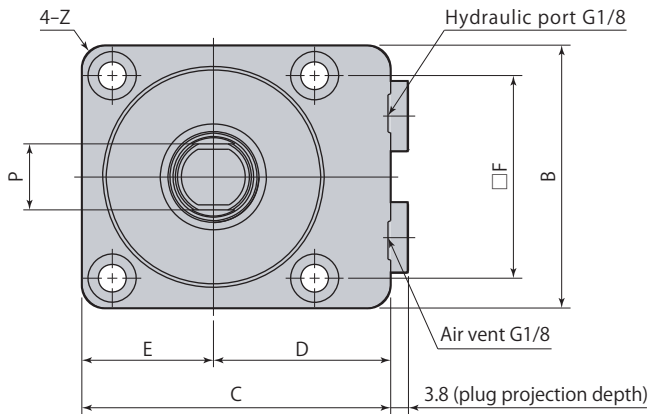

Mounting details

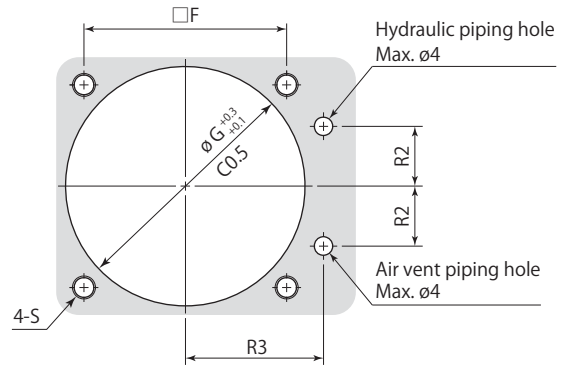

Plunger tip section details

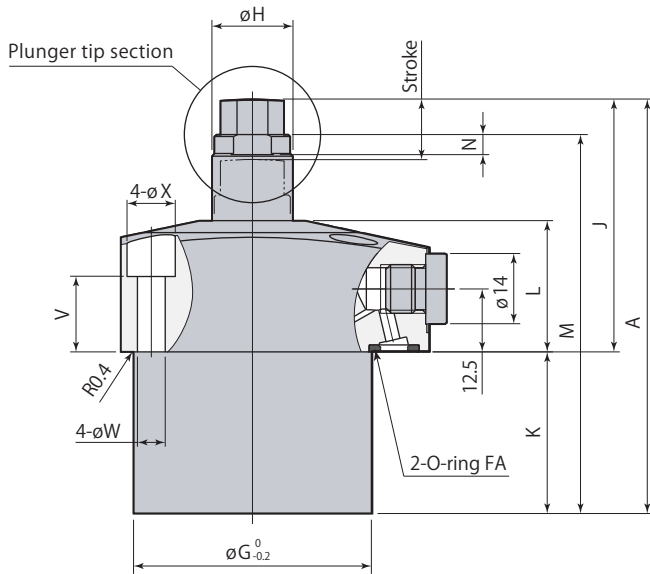
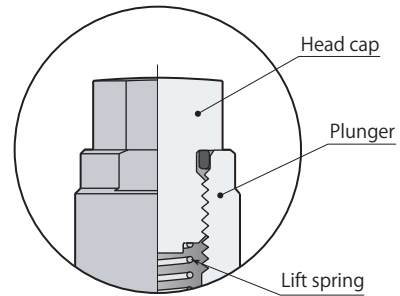

Head cap details

Hardness : HRC52

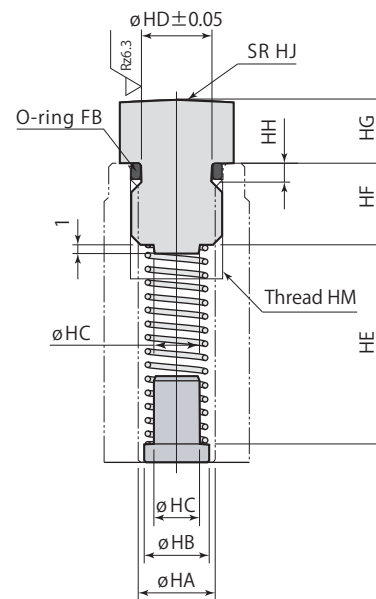
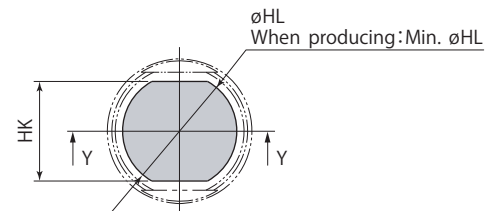

Y-Y

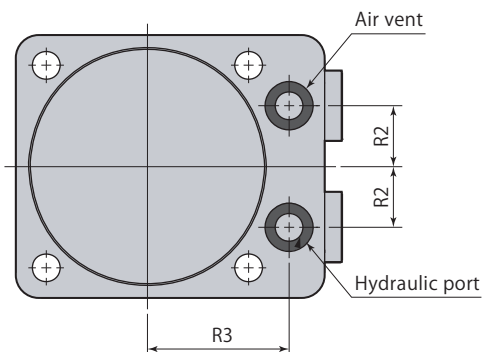

Model	CST04-□	CST06-□	CST10-□	CST16-□	CST25-□
A	67	82	85	108	129
B	45	52	56	65	78
C	55	61	65	73	85
D	32.5	35	37	40.5	46
E	22.5	26	28	32.5	39
F	34	40	44	52	62
øG	40	47	52	60	72
øH	15	16	20	22	25
J	46	50	52	61	62
K	21	32	33	47	67
L	26	26	28	30	30
M	60	75	78	99	120
N (width across flats height)	4	4	4.5	5	6
P (width across flats)	13	13	17	19	22
R2	10	12	13	15	18
R3	25.5	28	30	33.5	39
S	M5	M5	M5	M6	M8
V	15	15	16.5	15.9	12
W	5.5	5.5	5.5	6.8	9
X	9.5	9.5	9.5	11	14
Z	R3	R5	R5	R6	R7
O-ring FA (fluorocarbon hardness Hs90)	P7	P7	P7	P7	P7
Air bleeding valve	VCE01	VCE01	VCE01	VCE01	VCE01

- The mounting surface finish must be no rougher than Rz6.3 (ISO4287:1997).
- Always attach head cap (lift spring cannot be retained).
- Mounting screws are not included.

Head cap details

Model	CST04-□	CST06-□	CST10-□	CST16-□	CST25-□
øHA	8.5	8.5	10.3	10.3	14
øHB	7.2	7.2	9.2	9.2	11.2
øHC	5	5	6	6	7.5
øHD	7.8	7.8	9.2	9.2	13.5
HE	17.6	22	22.5	32.5	39
HF	9	9	11	11	15
HG	7	7	7	9	9
HH	1.9	1.9	2.3	2.3	3.5
HJ	70	70	90	110	140
HK	11	11	14	14	18
øHL	12.6	12.6	16.5	16.5	21.5
Min. øHL	12.5	12.5	16.5	16.5	21.5
HM (recommended tightening torque)	M10×1.5 depth 11 (30 N·m)	M10×1.5 depth 11 (30 N·m)	M12×1.75 depth 13 (50 N·m)	M12×1.75 depth 13 (50 N·m)	M16×2 depth 20 (80 N·m)
O-ring FB (fluorocarbon hardness Hs70)	S8	S8	P9	P9	AS568-014

- When fabricating head cap, ensure that O-ring slot, spring spot facing and guide are made by referring to head cap details. Be sure to always use included O-ring.
- When fabricating a lift spring, determine dimensions by referring to head cap details. Furthermore, rustproofing must be implemented (however, there is no guarantee for operation).
- This diagram indicates a situation where head cap has been fitted into plunger with no pressure applied.

Caution in use

- If the workpiece is light weight, the plunger cannot be pressed down by the weight of workpiece and seating detection cannot be complete. Review the weight of workpiece or lift spring force to make the workpiece seat perfectly, and lock the work support.

Spring pushes the workpiece

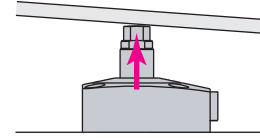

- Avoid following usages. These may cause sleeve deformation that could lead to malfunction of plunger or decreased support force.

- ✗ Applying eccentric load on plunger.
- ✗ Applying load that exceeds rated support force.
- ✗ Rotating plunger when locked.

- Air vent must be opened to atmosphere. Any blockage on the vent results in malfunction. Provide the piping if there is a risk of coolant or metal chips intrusion. Allowing intrusion of cutting fluid may cause rusting and other problems.

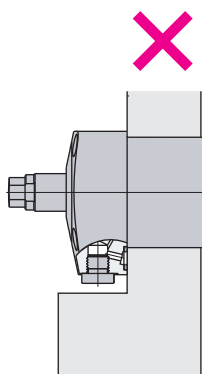

Air vent is blocked

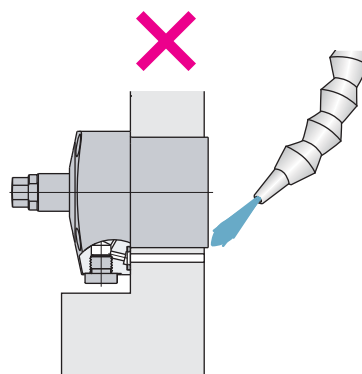

Cutting fluid intrusion from air vent

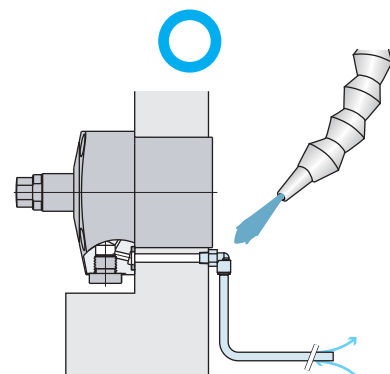

Piping to metal chips or coolant free area

- Air (oil free) must be fed through a $5\ \mu\text{m}$ filter that is connected to an air vent port for air cleaning. Perform air cleaning only when replacing workpiece.