

Standard model

model CTU□-□

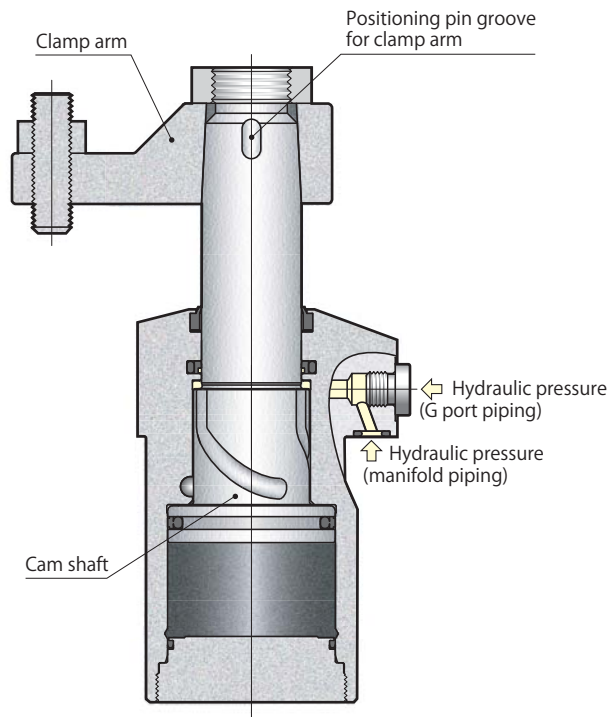

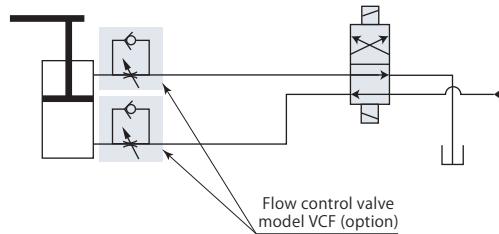

Hydraulic circuit diagram



For flow control valve, we recommend the meter-in control. If meter-out control is used, due to the area difference, it will cause back pressure and become high pressure. This can lead to malfunction of the system. Please be aware when designing the circuit.

- Specifications page → 3
- Standard page → 6
- Dual rod page → 10
- Pin rod page → 11
- Air sensor page → 12
- Swing angle 30°, 45°, 60° page → 16
- Long stroke page → 18

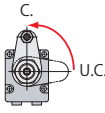
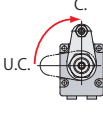
Specifications

CTU	Size	Swing direction (when clamping)	Variation code* ¹
	01	L : Counter-clockwise	
	02		
	04		
	06	R : Clockwise	
	10		
	16		
25* ²			
		(Nil) : Standard E : Dual rod P : Pin rod A : Air sensor N □ : Swing angle 30°, 45°, 60° S □ : Long stroke	
		 indicates made to order.	

*1: All varieties are not available for all sizes. Refer to each relevant page for details.

Contact Pascal for the details of variation codes (models) that are not described in the catalog.

*2: CTU25-□E, CTU25-□P, CTU25-□S30 are made to order.

Model		CTU01	CTU02	CTU04	CTU06	CTU10	CTU16	CTU25	
Cylinder force (hydraulic pressure 7MPa)	kN	2.4	2.8	4.4	6.3	9.9	16.3	25.8	
Cylinder inner diameter	mm	25	29	36	42	52	65	82	
Rod diameter	mm	14	18	22.4	25	30	35.5	45	
Effective area (clamp)	cm ²	3.4	4.1	6.2	8.9	14.2	23.3	36.9	
Swing angle		90° ± 3°							
Positioning pin groove position accuracy		± 1°							
Repeated clamp positioning accuracy		± 0.5°							
Full stroke	mm	16	18	20.5	23.5	26.5	28.5	36	
90° swing stroke	mm	8	10	12.5	13.5	16.5	18.5	23	
Clamp stroke	mm	8	8	8	10	10	10	13	
Max. swing torque* ¹	N·m	0.6	0.7	1.6	1.8	3.4	5.6	9.3	
Cylinder capacity	Clamp	cm ³	5.4	7.3	12.8	21.0	37.5	66.4	132.9
	Unclamp	cm ³	7.9	11.9	20.9	32.6	56.3	94.6	190.1
Mass	kg	0.7	0.9	1.3	1.7	2.8	4.7	9.9	
Recommended tightening torque of mounting screws* ²	N·m	3.5	7	7	12	29	57	77	
Recommended tightening torque of nut	N·m	12	26	51	60	86	120	180	

● Pressure range: 1–7 MPa ● Proof pressure: 10.5 MPa ● Operating temperature: 0–70 °C

● Fluid used: General mineral based hydraulic oil (ISO-VG32 equivalent)

● Seals are resistant to chlorine-based cutting fluid. (not thermal resistant specification)

*1: This is the limit value for lifting arm at 1 MPa when mounted vertically. *2: ISO R898 class 12.9

Manifold piping and G port piping are available.

Manifold piping

When choosing manifold piping, a flow control valve (model VCF) and an air bleeding valve (model VCE) are mountable on the G ports of the clamp.

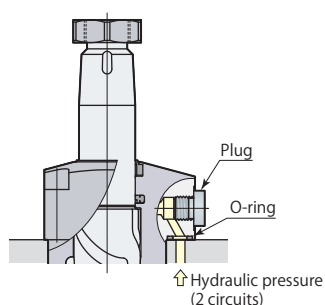

G port piping

Remove plugs when choosing G port piping. (O-ring must be used.) Refer to **page → 150** for details on G port piping flareless fitting. The flow control valve and the air bleeding valve should be installed in the middle of oil path.

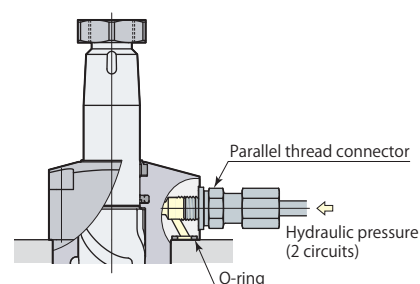

Swing speed adjustment

Swing time is restricted by the mass and length of the clamp arm (moment of inertia) since the 90° swing action impacts the cam shaft.

1. Calculate the moment of inertia according to the arm length and mass.
 2. Adjust swing speed with flow control valve to ensure that 90° swing time of the clamp arm is greater than the shortest swing time in the graph shown below.
- The cam groove may be damaged in case the swing speed is set at the nonusable range in the graph.

Example of calculation for moment of inertia

$$I = \frac{1}{12} m_1(4A_1^2 + B^2) + \frac{1}{12} m_2(4A_2^2 + B^2)$$

I : Moment of inertia (kg·m²)
m : Mass (kg)

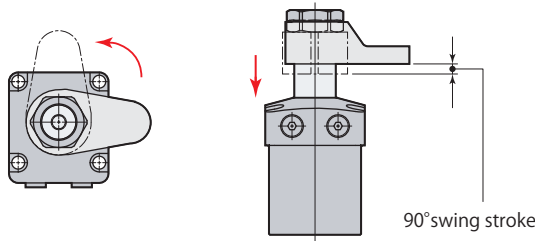
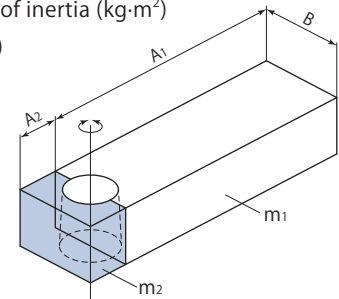

model CTU01

Shortest swing time calculation formula $t = \sqrt{\frac{I}{0.0270}}$

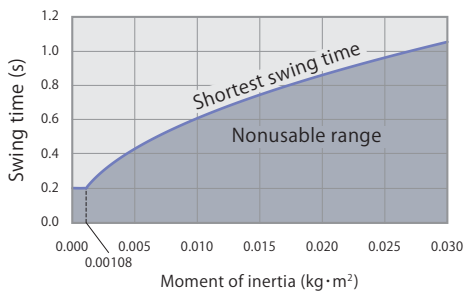

model CTU02

Shortest swing time calculation formula $t = \sqrt{\frac{I}{0.0305}}$

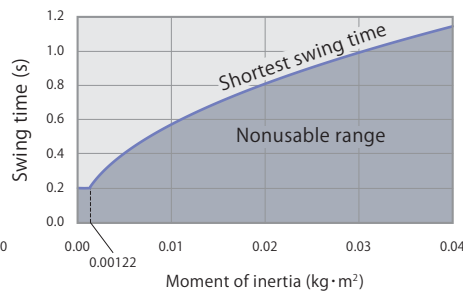

model CTU04

Shortest swing time calculation formula $t = \sqrt{\frac{I}{0.0668}}$

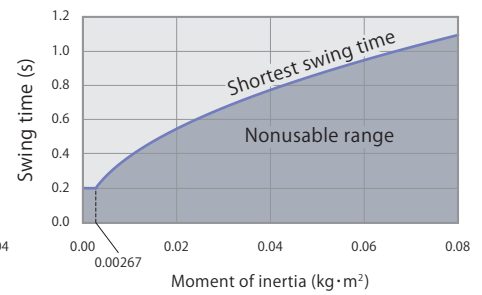

model CTU06

Shortest swing time calculation formula $t = \sqrt{\frac{I}{0.0730}}$

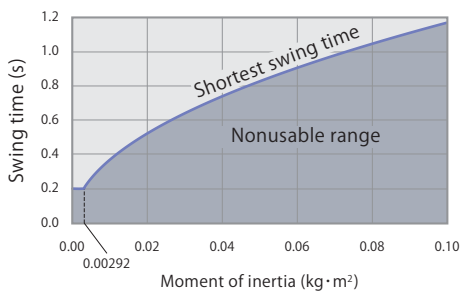

model CTU10

Shortest swing time calculation formula $t = \sqrt{\frac{I}{0.141}}$

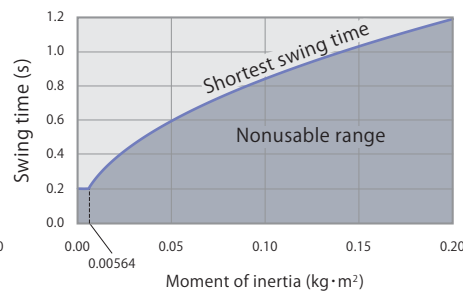

model CTU16

Shortest swing time calculation formula $t = \sqrt{\frac{I}{0.233}}$

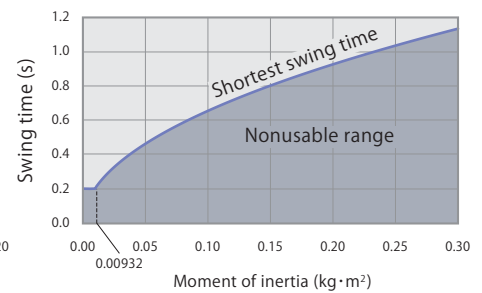

model CTU25

Shortest swing time calculation formula $t = \sqrt{\frac{I}{0.389}}$

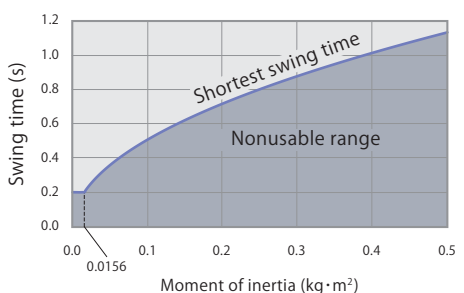

Dimensions

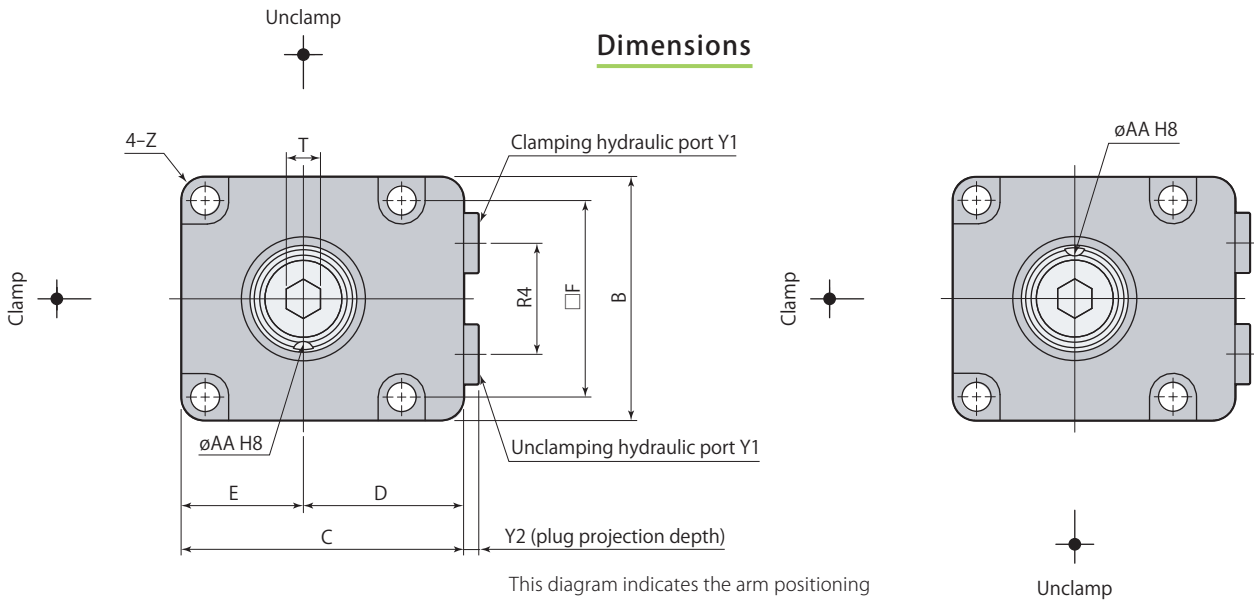

This diagram indicates the arm positioning pin groove at unclamped condition.

Swing direction L (counter-clockwise)

Swing direction R (clockwise)

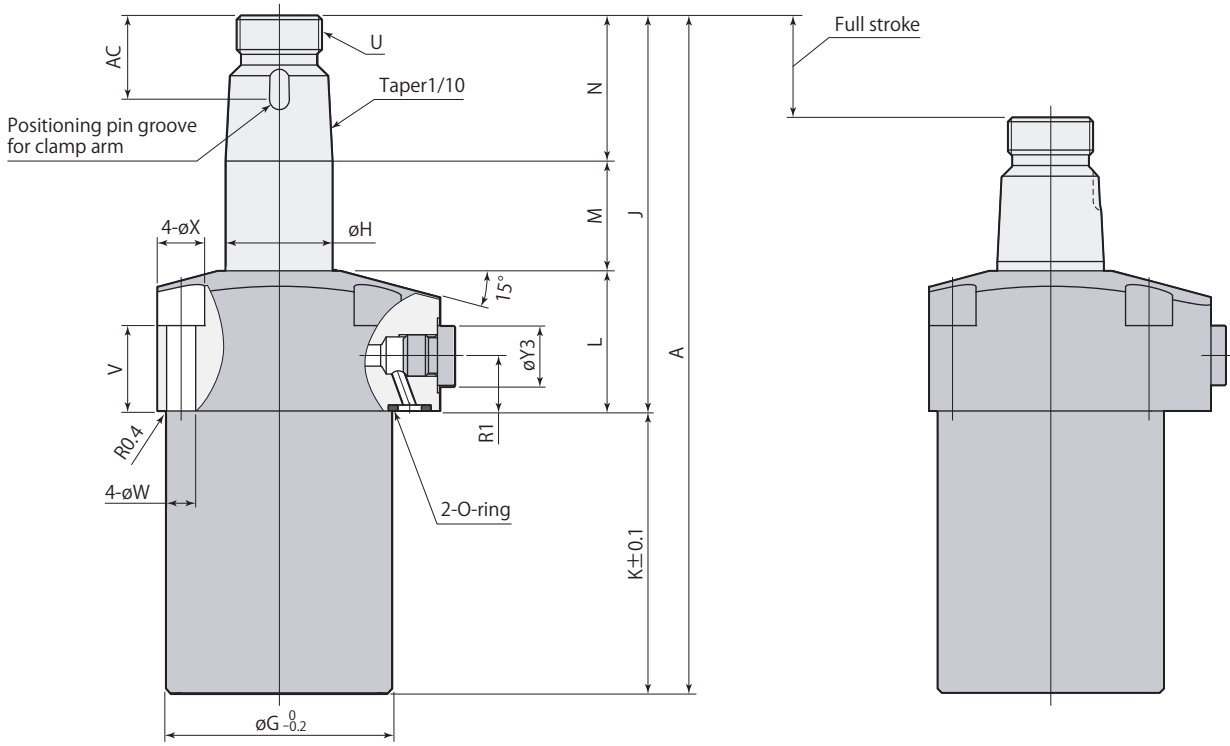

Unclamp

Stroke end

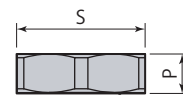
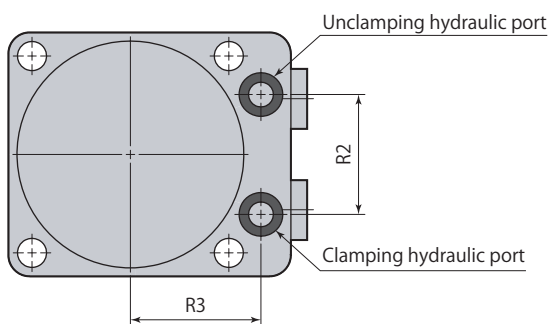

Hex nut for arm mount

- Hex nut for arm mount is included.
- Refer to **page →34** for the details of perfect nut.
- Clamp arm, positioning pin and mounting screws are not included.

CTU □-□	Swing clamp Standard model					7MPa	Double acting
----------------	-----------------------------------	--	--	--	--	-------------	----------------------

Model	CTU01-□	CTU02-□	CTU04-□	CTU06-□	CTU10-□	CTU16-□	CTU25-□	
A	117	131	148.5	158.5	178.5	201.5	244	
B	38	45	50	57	70	86	108	
C	48	55	60	66	82	96	120	
D	29	32.5	35	37.5	47	53	66	
E	19	22.5	25	28.5	35	43	54	
F	30.5	35	40	46	56	68	88	
øG	35	39	47	53	63	78	100	
øH	14	18	22.4	25	30	35.5	45	
J	68.5	77	87.5	92.5	101.5	117.5	147	
K	48.5	54	61	66	77	84	97	
L	28.5	29	31	33	36	40.5	51.5	
M	17.5	20	22.5	25.5	28.5	30	37.5	
N	22.5	28	34	34	37	47	58	
P	6.5	8	9	9	10	12	13	
R1	12.5	12.5	12.5	12.5	14	14	21	
R2	18	22	24	28	36	45	50	
R3	22.5	25	28	30.5	36	42	57	
R4	16.2	20	22	26	30	38	50	
S (nut width across flats)	19	22	27	30	36	46	55	
T (hex socket)	5	6	6	8	8	10	14	
U	M12×1.5	M14×1.5	M18×1.5	M20×1.5	M24×1.5	M30×1.5	M39×1.5	
V	20	19.5	20	20	19.5	20	26	
øW	4.3	5.5	5.5	6.8	9	11	14	
øX	8	9.5	9.5	11	14	17.5	20	
Y1	G1/8	G1/8	G1/8	G1/8	G1/4	G1/4	G3/8	
Y2	3.8	3.8	3.8	3.8	4.8	4.8	4.8	
øY3	14	14	14	14	19	19	22	
Z	R3	R3	R3	R5	R6	R7	R10	
øAA (pin groove diameter)	3 ^{+0.014} ₀	4 ^{+0.018} ₀	4 ^{+0.018} ₀	5 ^{+0.018} ₀	6 ^{+0.018} ₀	6 ^{+0.018} ₀	6 ^{+0.018} ₀	
AC	15.5	18.5	19.5	19.5	22.5	24.5	27.5	
Positioning pin (dowel pin)	ø3(h8)×8	ø4(h8)×10	ø4(h8)×10	ø5(h8)×10	ø6(h8)×12	ø6(h8)×12	ø6(h8)×14	
O-ring (fluorocarbon hardness Hs90)	P7	P7	P7	P7	P8	P8	P10	
Taper sleeve	CTH01-TS	CTH02-TS	CTH04-TS	CTH06-TS	CTH10-TS	CTH16-TS	CTH25-TS	
Flow control valve*	Meter-in	VCF01	VCF01	VCF01	VCF01	VCF02	VCF02	VCF03
	Meter-out	VCF01-O	VCF01-O	VCF01-O	VCF01-O	VCF02-O	VCF02-O	VCF03-O
Air bleeding valve*	VCE01	VCE01	VCE01	VCE01	VCE02	VCE02	VCE03	

*: Select the right model of VCF and VCE according to the size of the clamp.

Refer to each page for the details of options.

● Taper sleeve **page →21** ● Flow control valve **page →42** ● Air bleeding valve **page →44**

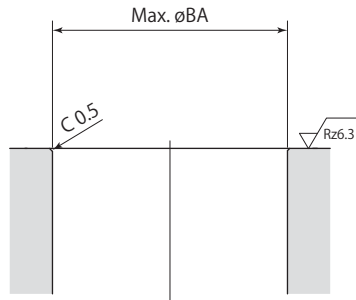
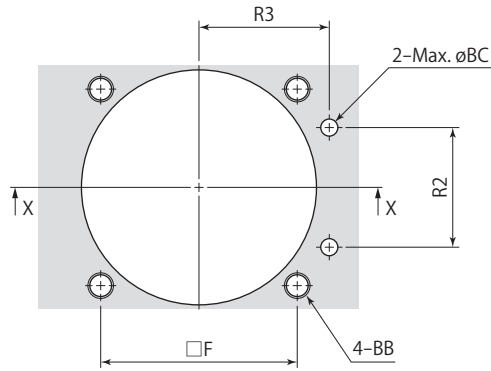
Mounting details

X-X

Rz: ISO4287(1997)

Model	CTU01-□	CTU02-□	CTU04-□	CTU06-□	CTU10-□	CTU16-□	CTU25-□
F	30.5	35	40	46	56	68	88
R2	18	22	24	28	36	45	50
R3	22.5	25	28	30.5	36	42	57
øBA	36	40	48	54	64	79	101
BB	M4	M5	M5	M6	M8	M10	M12
øBC	4	4	4	4	6	6	8

mm

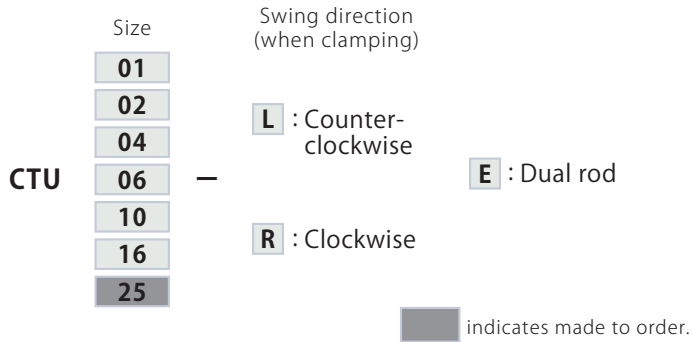

Usage example

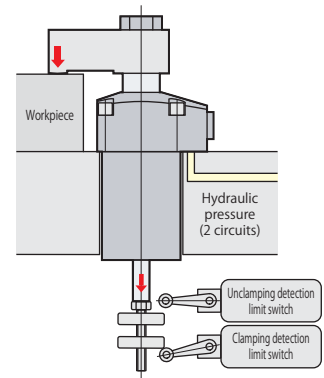

Dimensions

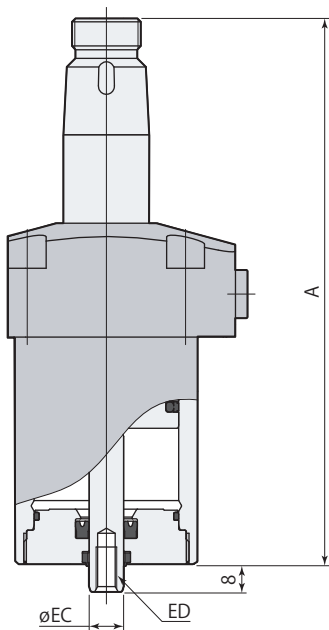

Unclamp

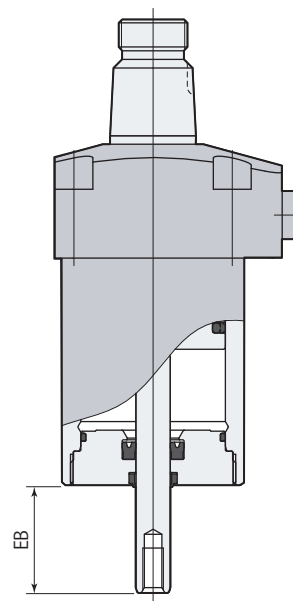

Stroke end

- This diagram indicates a swing direction L (L stands for counter-clockwise).
- Refer to specifications (page →3), dimensions (page →6) for other specifications and dimensions that are not shown in the diagram.

mm

Model	CTU01-□E	CTU02-□E	CTU04-□E	CTU06-□E	CTU10-□E	CTU16-□E	CTU25-□E
Cylinder capacity (unclamp)	7.0 cm ³	11.0 cm ³	19.3 cm ³	30.7 cm ³	53.3 cm ³	91.3 cm ³	182.9 cm ³
A	117	131	148.5	158.5	178.5	201.5	244
EB	24	26	28.5	31.5	34.5	36.5	44
øEC	8	8	10	10	12	12	16
ED	M5×0.8 depth 8	M5×0.8 depth 8	M6×1 depth 11	M6×1 depth 11	M8×1.25 depth 15	M8×1.25 depth 15	M10×1.5 depth 18
Mass	0.7 kg	0.9 kg	1.3 kg	1.7 kg	2.8 kg	4.7 kg	9.9 kg

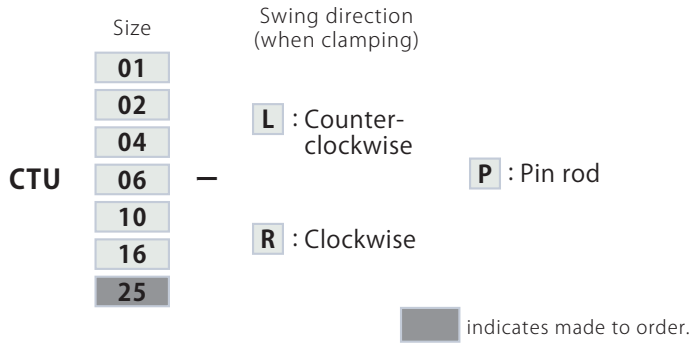

Dimensions

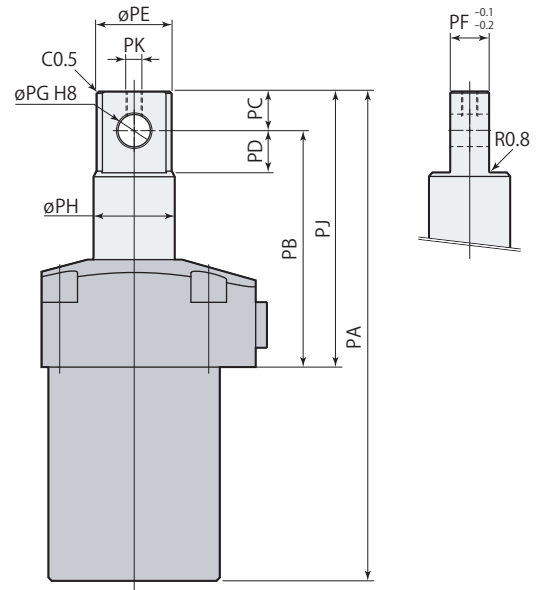

Usage example

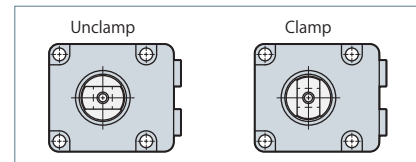
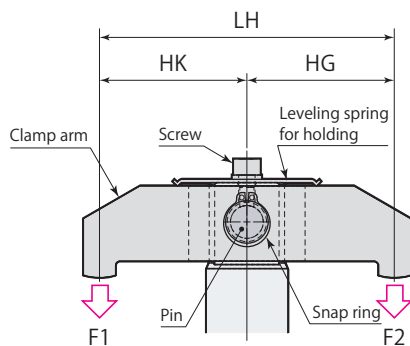

Clamping performance

Clamping force calculation formula

$$F1 = \frac{HG}{LH} \times n \times P$$

$$F2 = \frac{HK}{LH} \times n \times P$$

F1, F2=Clamping force (kN),
n=Coefficient (refer to right table),
P=Hydraulic pressure (MPa),
HG, HK=Distance from center of piston to clamping point (mm), LH=(mm)

Model	Coefficient n
CTU01-□P	0.336
CTU02-□P	0.406
CTU04-□P	0.624
CTU06-□P	0.895
CTU10-□P	1.42
CTU16-□P	2.33
CTU25-□P	3.69

- This diagram indicates unclamped condition. Direction of pin hole will be hydraulic port side at the time of clamping.
- Clamp arm, pin and snap ring are not included. Customers must arrange for them.
- Thread at top portion of the rod is for attaching a leveling spring. Screw and leveling spring are not included.
- Refer to specifications (page →3), dimensions (page →6) for other specifications and dimensions that are not shown in the diagram.

mm

Model	CTU01-□P	CTU02-□P	CTU04-□P	CTU06-□P	CTU10-□P	CTU16-□P	CTU25-□P
PA	113	121.5	137	151	172	195	236.5
PB	56.5	59.5	66	73	81	92	115.5
PC	8	8	10	12	14	19	24
PD	9	9	11	13	15	20	25
øPE	12	16	20.4	23	28	33.5	43
PF	8	8	10	12	16	18	22
øPG	6 ^{+0.018} ₀	6 ^{+0.018} ₀	8 ^{+0.022} ₀	10 ^{+0.022} ₀	12 ^{+0.027} ₀	16 ^{+0.027} ₀	20 ^{+0.033} ₀
øPH	14	18	22.4	25	30	35.5	45
PJ	64.5	67.5	76	85	95	111	139.5
PK	M3×0.5	M3×0.5	M4×0.7	M5×0.8	M6×1	M6×1	M8×1.25
Mass	0.6 kg	0.9 kg	1.3 kg	1.8 kg	3.0 kg	4.9 kg	9.5 kg

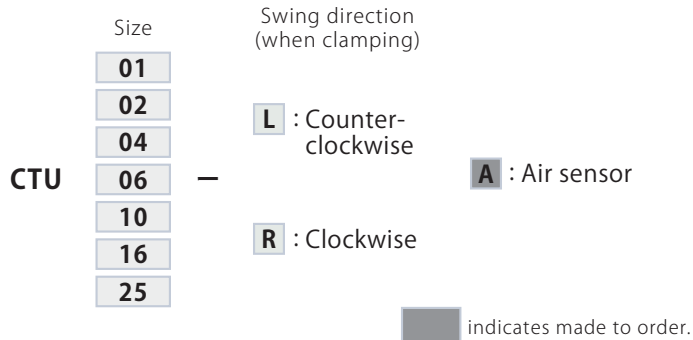

Usage example

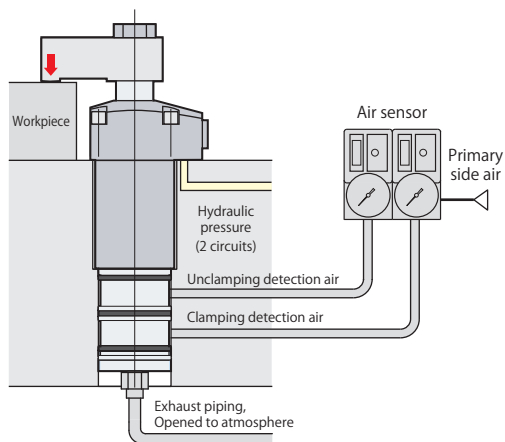

Dimensions

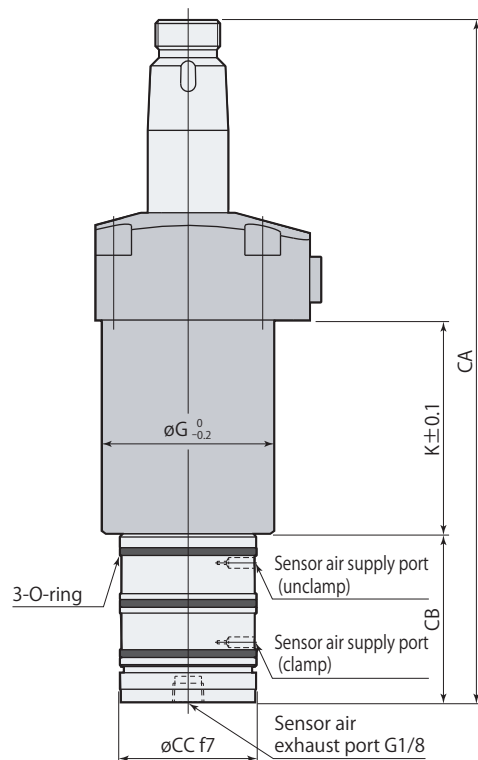

- This diagram indicates unclamped condition of swing direction L (L stands for counter-clockwise). Direction of positioning pin groove will be hydraulic port side at the time of clamping.
- Exhaust port must be opened to atmosphere.
If sensor is embedded, prepare an exhaust piping hole.
Furthermore, provide the piping if there is a risk of coolant or metal chips intrusion.
Use one-touch fittings manufactured by SMC for G port piping. (See SMC catalog for the details of the fitting.)
- Refer to specifications (page →3), dimensions (page →6) for other specifications and dimensions that are not shown in the diagram.

mm

Model	CTU01-□A	CTU02-□A	CTU04-□A	CTU06-□A	CTU10-□A	CTU16-□A	CTU25-□A
Cylinder capacity (unclamp)	7.0 cm ³	11.0 cm ³	19.3 cm ³	30.7 cm ³	53.3 cm ³	91.3 cm ³	182.9 cm ³
CA	159	175	197.5	210.5	233.5	258.5	311.5
CB	42	44	49	52	55	57	67.5
øCC	33 ^{-0.025 -0.050}	38 ^{-0.025 -0.050}	42 ^{-0.025 -0.050}	42 ^{-0.025 -0.050}	45 ^{-0.025 -0.050}	45 ^{-0.025 -0.050}	52 ^{-0.030 -0.060}
øG	35	39	47	53	63	78	100
K	48.5	54	61	66	77	84	97
O-ring (fluorocarbon hardness Hs70)	AS568-025	AS568-028	AS568-029	AS568-029	AS568-030	AS568-030	AS568-032
Mass	0.8 kg	1.0 kg	1.6 kg	2.0 kg	3.2 kg	5.2 kg	10.1 kg

Mounting details

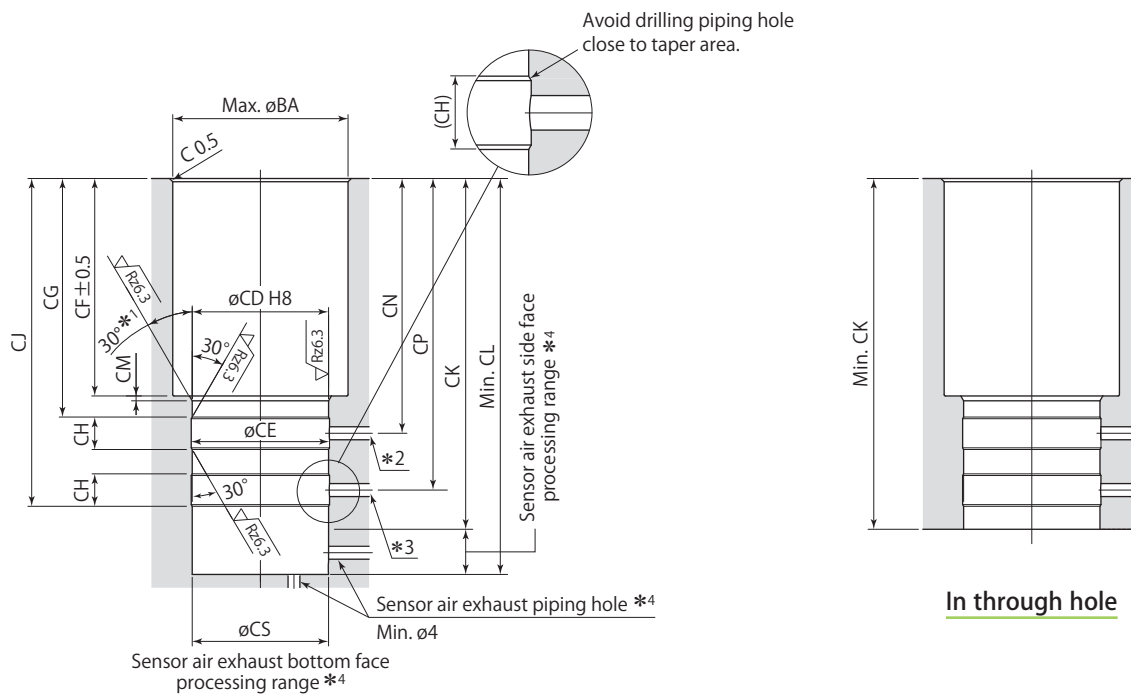

In blind hole

Rz: ISO4287(1997)

*1: 15° only for CTU01-□A , CTU02-□A

*2: Sensor air piping hole (unclamp) ø4 to ø6. ø4 to ø5 only for CTU01-□A.

*3: Sensor air piping hole (clamp) ø4 to ø6. ø4 to ø5 only for CTU01-□A.

*4: Sensor air exhaust piping hole must be made on either side or bottom face.

- Apply an appropriate amount of grease to the chamfer and the bore when mounting. Excessive grease may be a blockage in the air passage, causing malfunction of the sensor.
- The 30° taper machining must be provided to avoid the damage of the O-ring. Ensure that there are no interference on taper area when drilling the hole for sensor air.

mm

Model	CTU01-□A	CTU02-□A	CTU04-□A	CTU06-□A	CTU10-□A	CTU16-□A	CTU25-□A
øCD	33 ^{+0.039} ₀	38 ^{+0.039} ₀	42 ^{+0.039} ₀	42 ^{+0.039} ₀	45 ^{+0.039} ₀	45 ^{+0.039} ₀	52 ^{+0.046} ₀
øCE	33.6	38.6	42.6	42.6	45.6	45.6	52.6
CF	49.5	55	62	67	78	85	98
CG	56 ^{+0.5} ₀	61.5 ^{+0.5} ₀	68.5 ⁺¹ ₀	73.5 ⁺¹ ₀	84.5 ⁺¹ ₀	91.5 ⁺¹ ₀	104.5 ⁺¹ ₀
CH	8	8.5	10	10	10	10	10
CJ	77 ⁰ _{-0.5}	84.5 ⁰ _{-0.5}	95.5 ⁰ ₋₁	101 ⁰ ₋₁	116.5 ⁰ ₋₁	123.5 ⁰ ₋₁	144.5 ⁰ ₋₁
CK	84	91.5	101.5	106.5	123.5	130.5	156
CL	94.5	102	114	122	136	145	168.5
CM	1	1	1.5	1.5	1.5	1.5	1.5
CN	60	66	73.5	78.5	89.5	96.5	109.5
CP	73	80	90.5	96	111.5	118.5	139.5
øCS	33	38	42	42	45	45	52
øBA	36	40	48	54	64	79	101

Air sensor

Supplier and model	ISA3-G series manufactured by SMC
	GPS2-05 series manufactured by CKD
Air supply pressure	0.2 MPa
Inner diameter of piping	ø4 mm
Overall piping length	5 m or less

- Supply the dry and filtered air. Particulate size $5\ \mu\text{m}$ or less is recommended.
- Use a solenoid valve with needle for air sensor unit and control it supplying air all the time in order to eliminate intrusion of chips or coolant.

- There is a case that air sensing cannot be successfully made as designed when it is used out of the usage shown on the left. Contact Technical service center for more details.
- Refer to the sensor supplier's instruction manual for the details of setting.
- Sensing performance such as detectable time and pressure differs depending on the supplier and model number of the sensor. Select the right model referring to sensor's application and characteristics.
- Maximum 6 pieces of clamp can be detected at 0.2MPa air pressure by means of 1 piece of sensor. In case of 0.1MPa air pressure, maximum 3 piece of clamp are detectable.

Air sensor triggering point

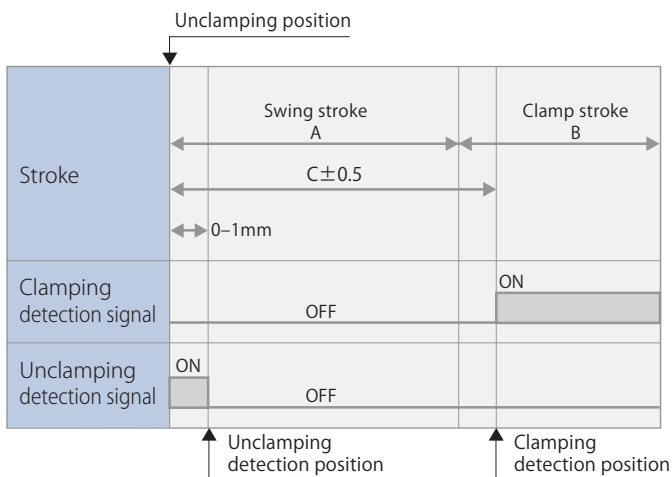

Model	Swing stroke A	Clamp stroke B	Clamping detection position C
CTU01-□A	8	8	9
CTU02-□A	10	8	11
CTU04-□A	12.5	8	13.5
CTU06-□A	13.5	10	14.5
CTU10-□A	16.5	10	17.5
CTU16-□A	18.5	10	19.5
CTU25-□A	23	13	24

Hydraulic and pneumatic circuit diagram

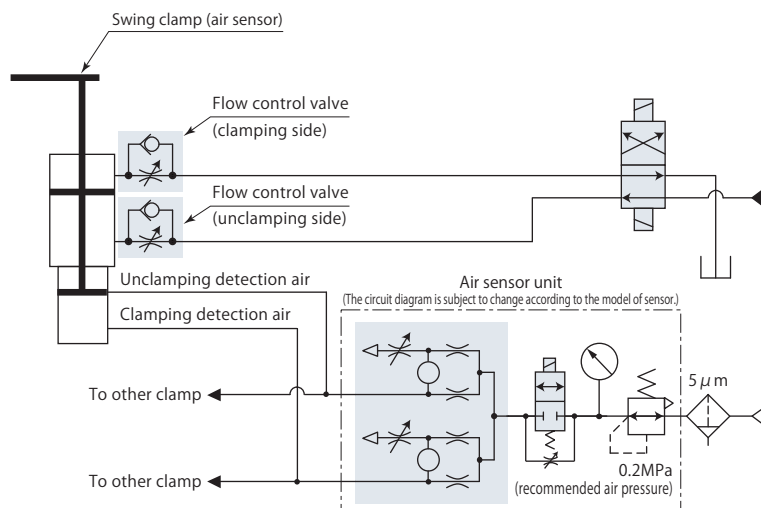

CTU	Size		Swing direction (when clamping)	
	01			
	02			
	04			
	06	-	L : Counter-clockwise	N30 : Swing angle 30°
	10			N45 : Swing angle 45°
	16		R : Clockwise	N60 : Swing angle 60°
25				

Swing angle

CTU□-□N30

Swing angle 30°

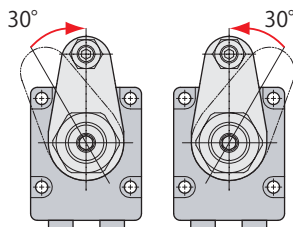

R:Clockwise L:Counter-clockwise

CTU□-□N45

Swing angle 45°

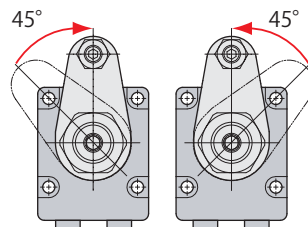

R:Clockwise L:Counter-clockwise

CTU□-□N60

Swing angle 60°

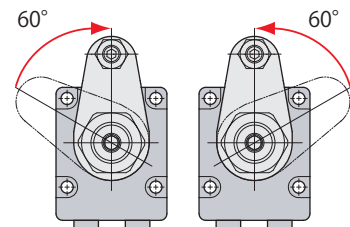

R:Clockwise L:Counter-clockwise

Specifications

Model		CTU01-□N□			CTU02-□N□			CTU04-□N□			CTU06-□N□			
Swing angle		30°±3°	45°±3°	60°±3°	30°±3°	45°±3°	60°±3°	30°±3°	45°±3°	60°±3°	30°±3°	45°±3°	60°±3°	
Full stroke		mm	11.8	12.7	13.7	13.0	14.3	15.5	14.3	15.8	17.4	16.8	18.4	20.1
Swing stroke		mm	3.8	4.7	5.7	5.0	6.3	7.5	6.3	7.8	9.4	6.8	8.4	10.1
Clamp stroke		mm	8			8			8			10		
Cylinder capacity	Clamp	cm ³	4.0	4.3	4.6	5.3	5.8	6.3	8.9	9.9	10.8	15.0	16.5	18.0
	Unclamp	cm ³	5.8	6.2	6.7	8.6	9.4	10.2	14.5	16.1	17.7	23.3	25.5	27.9

Model		CTU10-□N□			CTU16-□N□			CTU25-□N□			
Swing angle		30°±3°	45°±3°	60°±3°	30°±3°	45°±3°	60°±3°	30°±3°	45°±3°	60°±3°	
Full stroke		mm	18.3	20.3	22.4	19.3	21.6	23.9	24.5	27.4	30.3
Swing stroke		mm	8.3	10.3	12.4	9.3	11.6	13.9	11.5	14.4	17.3
Clamp stroke		mm	10			10			13		
Cylinder capacity	Clamp	cm ³	25.9	28.8	31.7	44.8	50.2	55.6	90.4	101.0	111.6
	Unclamp	cm ³	38.8	43.1	47.5	63.9	71.5	79.2	129.4	144.6	159.8

● Refer to **page →3** for specifications of products that are not listed on this page.

Dimensions

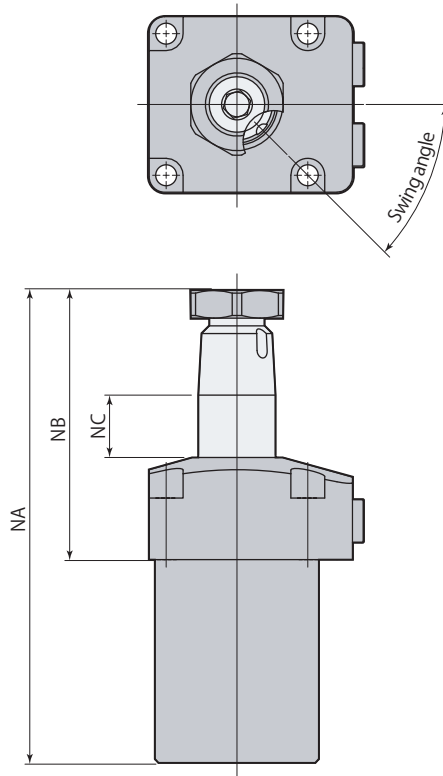

Swing direction L (counter-clockwise)

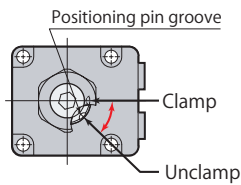

Swing direction R (clockwise)

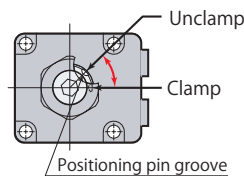

● This diagram indicates unclamped condition of swing direction L (L stands for counter-clockwise). Direction of positioning pin groove will be hydraulic port side at the time of clamping.

● Refer to dimensions (page →6) for dimensions of products that are not listed on this page.

Model	CTU01-□N□			CTU02-□N□			CTU04-□N□			CTU06-□N□		
	30°±3°	45°±3°	60°±3°	30°±3°	45°±3°	60°±3°	30°±3°	45°±3°	60°±3°	30°±3°	45°±3°	60°±3°
NA	112.8	113.7	114.7	126.0	127.3	128.5	142.3	143.8	145.4	151.8	153.4	155.1
NB	64.3	65.2	66.2	72.0	73.3	74.5	81.3	82.8	84.4	85.8	87.4	89.1
NC	13.3	14.2	15.2	15.0	16.3	17.5	16.3	17.8	19.4	18.8	20.4	22.1

Model	CTU10-□N□			CTU16-□N□			CTU25-□N□		
	30°±3°	45°±3°	60°±3°	30°±3°	45°±3°	60°±3°	30°±3°	45°±3°	60°±3°
NA	170.3	172.3	174.4	192.3	194.6	196.9	232.5	235.4	238.3
NB	93.3	95.3	97.4	108.3	110.6	112.9	135.5	138.4	141.3
NC	20.3	22.3	24.4	20.8	23.1	25.4	26.0	28.9	31.8

Size

01
02
04
06
10
16
25

Swing direction (when clamping)

L : Counter-clockwise
R : Clockwise

Clamp stroke

S16 : 16mm
S20 : 20mm
S25 : 25mm
S30 : 30mm
S50 : 50mm

CTU -

■ indicates made to order.

Size, stroke and shape of flange

CTU size	01	02	04	06	10	16	25	Shape of flange
Clamp stroke mm	16		20		30			Standard page →18
	-	25	30	30	50	-		Round page →19

Specifications

Model		CTU01-□S16	CTU02-□S16	CTU04-□S16	CTU06-□S20	CTU10-□S20	CTU16-□S20	CTU25-□S30
Full stroke	mm	24	26	28.5	33.5	36.5	38.5	53
Clamp stroke	mm	16	16	16	20	20	20	30
Cylinder capacity	Clamp	cm ³	8.1	10.6	17.8	30.0	51.7	89.6
	Unclamp	cm ³	11.8	17.2	29.0	46.4	77.5	127.8
Mass	kg	0.8	1.1	1.6	2.1	3.4	5.5	11.7

● Refer to standard (page →3) for specifications of products that are not listed on this page.

Dimensions

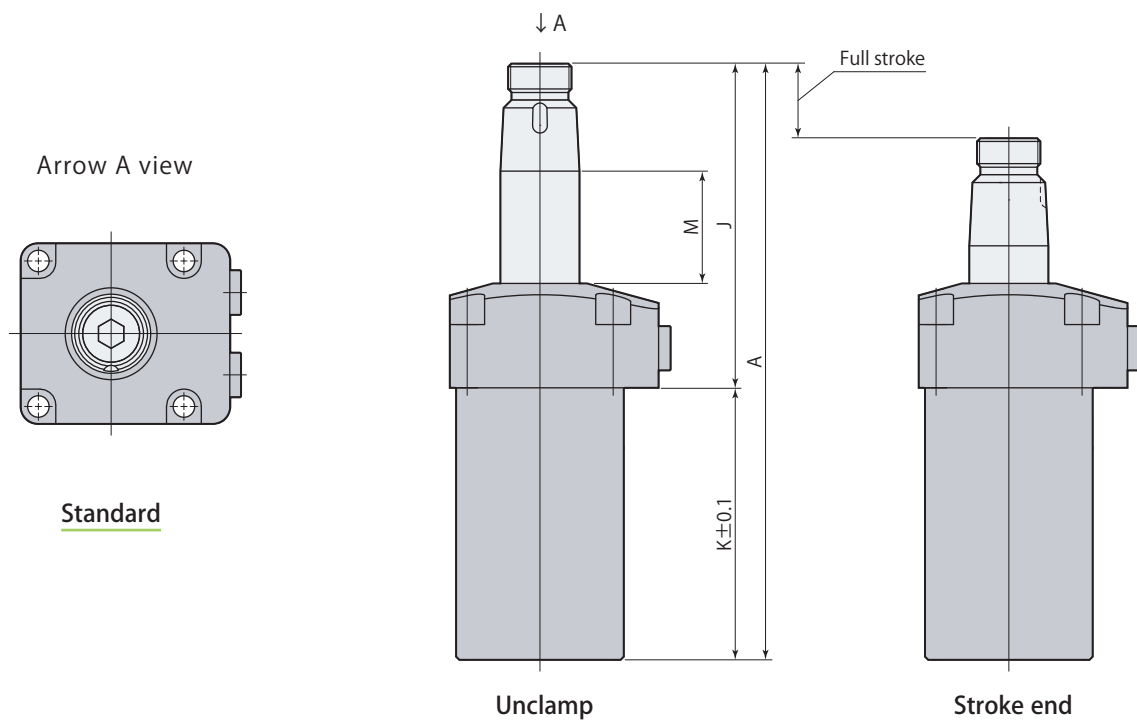

● Flange size is same as standard stroke model.

Refer to section for standard stroke model (page →6) for dimensions of products that are not listed on this page.

Model	CTU01-□S16	CTU02-□S16	CTU04-□S16	CTU06-□S20	CTU10-□S20	CTU16-□S20	CTU25-□S30
A	141	155	172.5	188.5	208.5	231.5	295
J	76.5	85	95.5	102.5	111.5	127.5	164
K	64.5	70	77	86	97	104	131
M	25.5	28	30.5	35.5	38.5	40	54.5

Specifications

Model		CTU04-□S25	CTU06-□S30	CTU10-□S30	CTU10-□S50	CTU16-□S30	CTU16-□S50
Full stroke	mm	37.5	43.5	46.5	66.5	48.5	68.5
Clamp stroke	mm	25	30	30	50	30	50
Cylinder capacity	Clamp	cm ³	23.4	38.9	65.9	94.2	112.9
	Unclamp	cm ³	38.2	60.3	98.8	141.2	160.9
Mass	kg	2.3	3.1	5.0	6.0	7.5	8.7

● Refer to standard (page →3) for specifications of products that are not listed on this page.

Dimensions

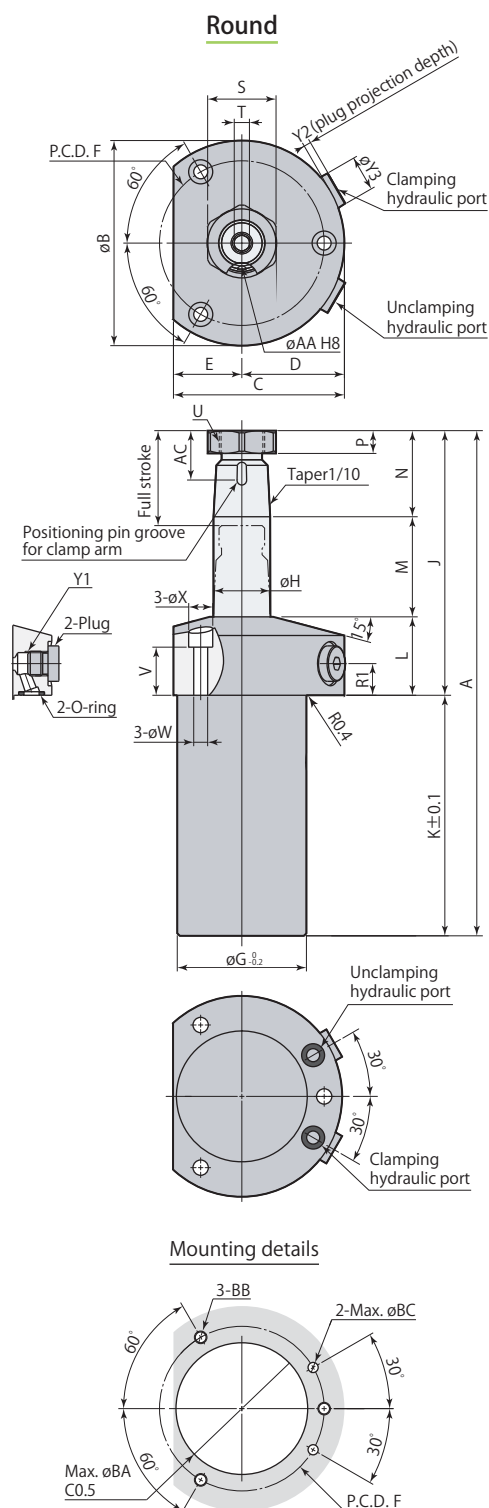

Model	CTU04-□S25	CTU06-□S30	CTU10-□S30	CTU10-□S50	CTU16-□S30	CTU16-□S50
A	199.5	218.5	238.5	298.5	261.5	321.5
øB	81	89	112	112	125	125
C	67.5	75	92.5	92.5	105.5	105.5
D	40.5	44.5	56	56	62.5	62.5
E	27	30.5	36.5	36.5	43	43
F	65	73	88	88	101	101
øG	51	58	70	70	83	83
øH	22.4	25	30	30	35.5	35.5
J	104.5	112.5	121.5	141.5	137.5	157.5
K	95	106	117	157	124	164
L	31	33	36	36	40.5	40.5
M	39.5	45.5	48.5	68.5	50	70
N	34	34	37	37	47	47
P (nut thickness)	9	9	10	10	12	12
R1	12.5	12.5	14	14	14	14
S (nut width across flats)	27	30	36	36	46	46
T (hex socket)	6	8	8	8	10	10
U	M18×1.5	M20×1.5	M24×1.5	M24×1.5	M30×1.5	M30×1.5
V	19	19.5	19	19	20	20
øW	5.5	6.8	9	9	11	11
øX	9.5	11	14	14	17.5	17.5
Y1	G1/8	G1/8	G1/4	G1/4	G1/4	G1/4
Y2	2.8	2.8	3.8	3.8	3.8	3.8
øY3	14	14	19	19	19	19
O-ring*	P7	P7	P8	P8	P8	P8
øAA (pin groove diameter)	4 ^{+0.018} ₀	5 ^{+0.018} ₀	6 ^{+0.018} ₀	6 ^{+0.018} ₀	6 ^{+0.018} ₀	6 ^{+0.018} ₀
AC	19.5	19.5	22.5	22.5	24.5	24.5
øBA	52	59	71	71	84	84
BB	M5	M6	M8	M8	M10	M10
øBC	4	4	6	6	6	6
Positioning pin (dowel pin)	ø4(h8)×10	ø5(h8)×10	ø6(h8)×12	ø6(h8)×12	ø6(h8)×12	ø6(h8)×12

*: Fluorocarbon hardness Hs90 ● This diagram indicates unclamped condition of swing direction L (L stands for counter-clockwise).

Clamp arm mounting details

Clamp arm is not included. Manufacture a clamp arm with the dimensions shown in the table below.

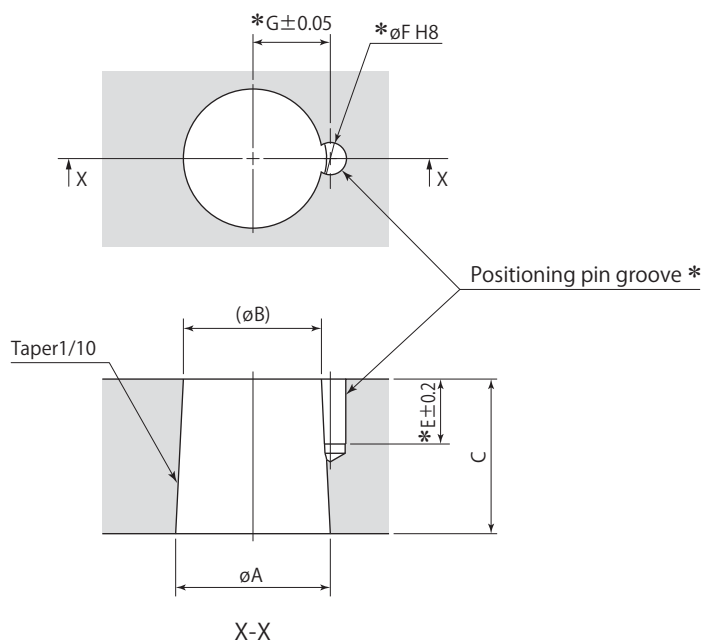

*: No need to machine the pin groove (E, ϕF , G) unless positioning pin is used for the arm.
The positioning pin enables a clamp arm to locate on the clamp firmly and easily.

Swing clamp	CTU01	CTU02	CTU04	CTU06	CTU10	CTU16	CTU25
ϕA	14 ^{-0.016} _{-0.034}	18 ^{-0.016} _{-0.034}	22.4 ^{-0.020} _{-0.041}	25 ^{-0.020} _{-0.041}	30 ^{-0.020} _{-0.041}	35.5 ^{-0.025} _{-0.050}	45 ^{-0.025} _{-0.050}
ϕB	12.4	16	19.9	22.5	27.3	32	40.5
C	16	20	25	25	27	35	45
E	9	10.5	10.5	10.5	12.5	12.5	14.5
ϕF (pin groove diameter)	3 ^{+0.014} ₀	4 ^{+0.018} ₀	4 ^{+0.018} ₀	5 ^{+0.018} ₀	6 ^{+0.018} ₀	6 ^{+0.018} ₀	6 ^{+0.018} ₀
G	7.55	9.1	11.1	12.6	15.1	18.1	22.6

mm

Taper sleeve

Size

01
02
04
06
10
16
25

CTH — **TS** : Taper sleeve

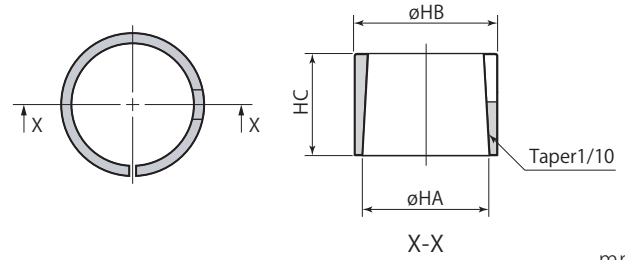

Taper sleeve	CTH01-TS	CTH02-TS	CTH04-TS	CTH06-TS	CTH10-TS	CTH16-TS	CTH25-TS
Applicable swing clamp	CTU01	CTU02	CTU04	CTU06	CTU10	CTU16	CTU25
øHA	14	18	22.4	25	30	35.5	45
øHB	16	20	25	28	34	40	49
HC	13	16	21	20	22	29	38

Clamp arm mounting details

(Using taper sleeve)

Clamp arm is not included. Manufacture a clamp arm with the dimensions shown in the table below.

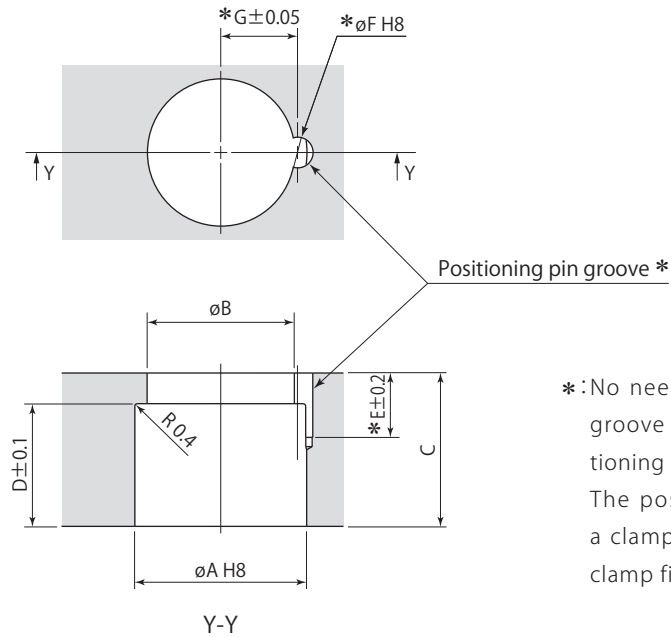

*: No need to machine the pin groove (E, øF, G) unless positioning pin is used for the arm. The positioning pin enables a clamp arm to locate on the clamp firmly and easily.

Taper sleeve	CTH01-TS	CTH02-TS	CTH04-TS	CTH06-TS	CTH10-TS	CTH16-TS	CTH25-TS
Applicable swing clamp	CTU01	CTU02	CTU04	CTU06	CTU10	CTU16	CTU25
øA	16 ^{+0.027} ₀	20 ^{+0.033} ₀	25 ^{+0.033} ₀	28 ^{+0.033} ₀	34 ^{+0.039} ₀	40 ^{+0.039} ₀	49 ^{+0.039} ₀
øB	13	17	21	24	28.5	34	42
C	16	20	25	25	27	35	45
D	13	16	21	20	22	29	38
E	9	10.5	10.5	10.5	12.5	12.5	14.5
øF (pin groove diameter)	3 ^{+0.014} ₀	4 ^{+0.018} ₀	4 ^{+0.018} ₀	5 ^{+0.018} ₀	6 ^{+0.018} ₀	6 ^{+0.018} ₀	6 ^{+0.018} ₀
G	7.55	9.1	11.1	12.6	15.1	18.1	22.6