

# Sensing Link clamp

Single acting 7 MPa

model **CLN**

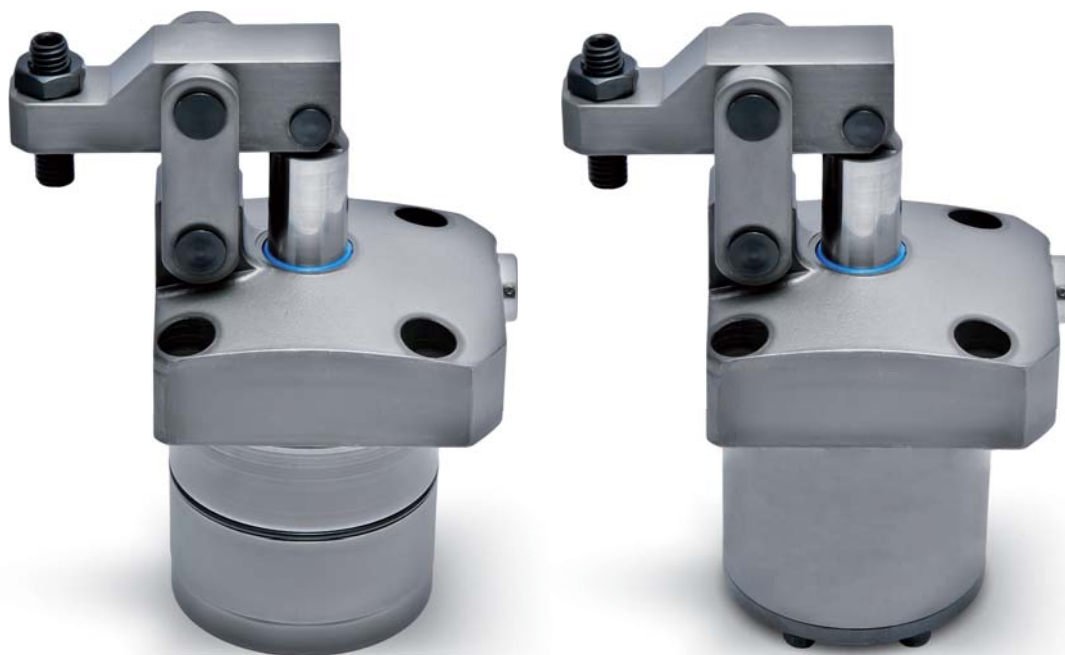

Unclamp sensor model  
model CLN06-FB

Compact model  
model CLN06-FN

# Sensing Link clamp model CLN

The extremely small sensing clamp can detect the loading miss of a workpiece firmly.

Unclamp sensor model



- Unclamp PAL sensor moves along with the piston rod and can positively detect unclamping point, thereby enabling a high-speed production line by fully synchronizing operation with workpiece lifters.
- Built-in sensors enable a compact and simple jig.
- Unclamp detection failure due to the metal chips deposit on an independent external detector can be reduced. (Figure 1)

Figure 1

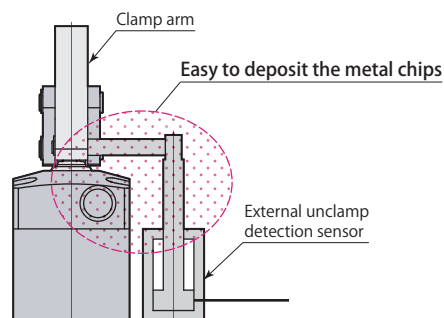

**Unclamp sensor model B**

model **CLN□-□B** PAT.

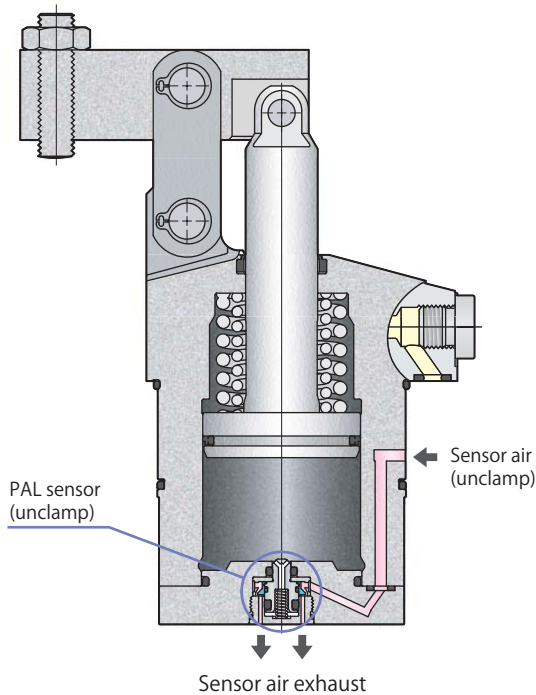

**Compact model N**

model **CLN□-□N** No sensors available on compact model

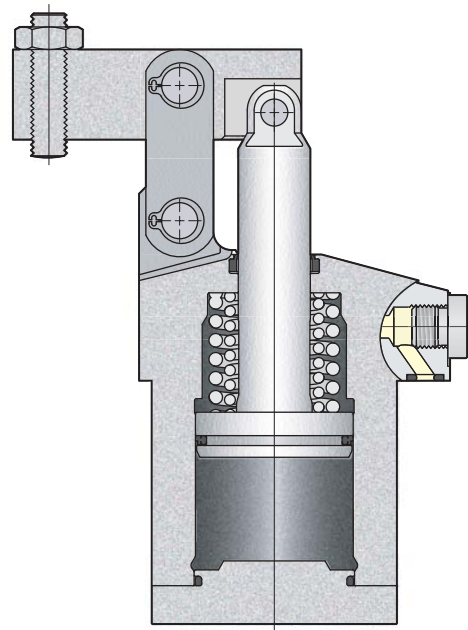

Hydraulic and pneumatic circuit diagram

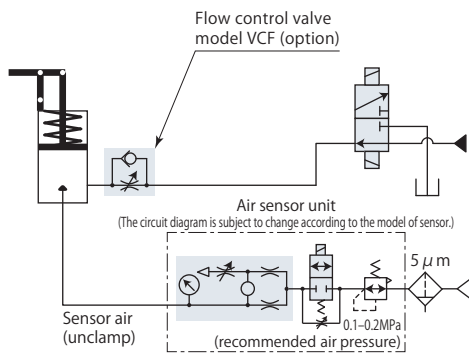

- Specifications page → 136
- Piping page → 137
- PAL sensor page → 141
- Dimensions page → 144
- Mounting details page → 146

Hydraulic circuit diagram

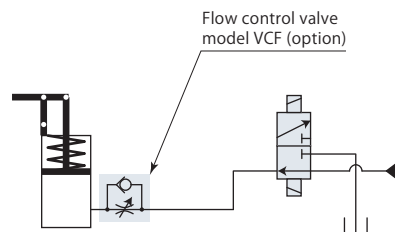

- Specifications page → 136
- Piping page → 137
- Dimensions page → 148
- Mounting details page → 150

Single acting  
Sensing  
Link clamp  
CLN

Specifications

Size

CLN —

04

05

06

10

16

Clamp arm mounting direction

L : Left side

F : Front side

R : Right side

B : Unclamp sensor model

N : Compact model

Model		CLN04	CLN05	CLN06	CLN10	CLN16	
Cylinder force (hydraulic pressure 7MPa)*1	kN	3.5	4.6	6.1	10.3	15.1	
Cylinder inner diameter	mm	26	30	35	45	55	
Rod diameter	mm	12	14	16	20	22	
Effective area (clamp)	cm <sup>2</sup>	5.3	7.1	9.6	15.9	23.8	
Full stroke	mm	20.5	23.5	26	29.5	35	
Clamp stroke*2	mm	17.5	20.5	23	26.5	32	
Safety stroke	mm	3	3	3	3	3	
Max. oil flow rate	L/min	1.1	1.7	2.6	5.1	9.1	
Cylinder capacity	cm <sup>3</sup>	10.9	16.6	25.0	46.9	83.2	
Return spring force	Clamp	kN	0.25	0.40	0.63	0.81	1.52
	Unclamp	kN	0.13	0.19	0.33	0.44	0.84
Recommended piping inner diameter*3	mm	ø6	ø6	ø6	ø8	ø8	
Max. allowable mass of clamp arm*4	kg	0.2	0.3	0.5	1.0	1.5	
Mass	kg	0.7	1.1	1.4	2.3	3.8	
Recommended tightening torque of mounting screws*5	N·m	7	7	12	12	29	

- Pressure range: 1.5–7 MPa
- Proof pressure: 10.5 MPa
- Operating temperature: 0–70 °C
- Fluid used: General mineral based hydraulic oil (ISO-VG32 equivalent)
- Seals are resistant to chlorine-based cutting fluid. (not thermal resistant specification)

- \*1: This is value for clamping position.
- \*2: Indicates a distance from unclamping position to clamping point.
- \*3: Care must be taken when numerous clamps are used or when hydraulic piping is long.
- \*4: This is clamp arm mass when shape of clamp arm being described in Dimensions is retained but length only has been extended.
- \*5: ISO R898 class 12.9

When clamping the workpiece, the clamp arm should be situated like the sketch as shown below. (Clamping point)  
Please avoid any non-axial force such as the bending moment toward the piston rod. (Allowable angle ±3°)

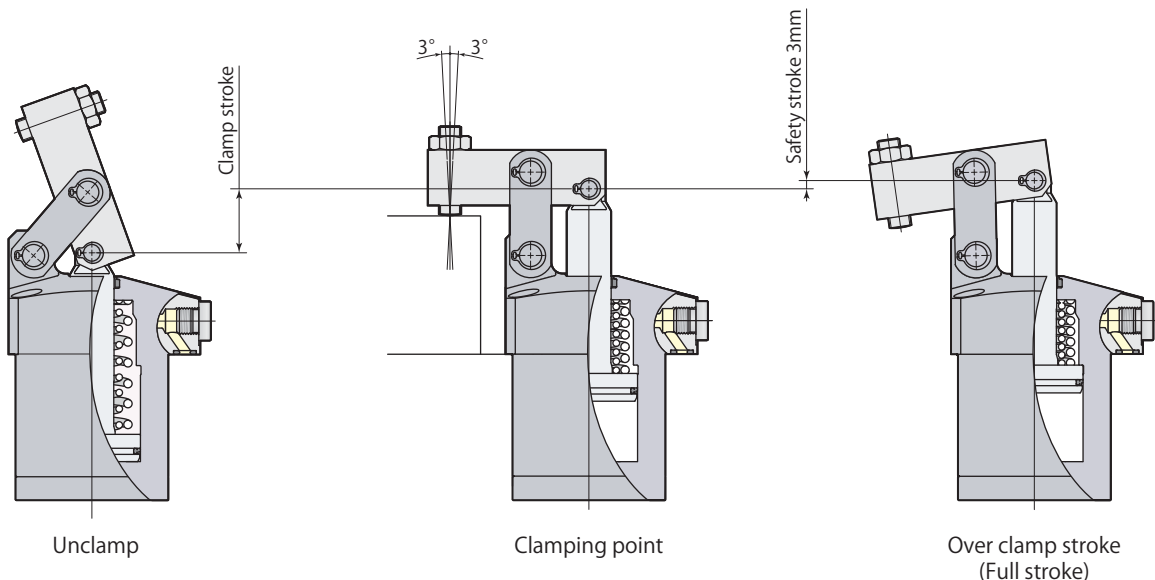

Manifold piping and G port piping are available.

Manifold piping

When choosing manifold piping, a flow control valve (model VCF) and an air bleeding valve (model VCE) are mountable on the G ports of the clamp.

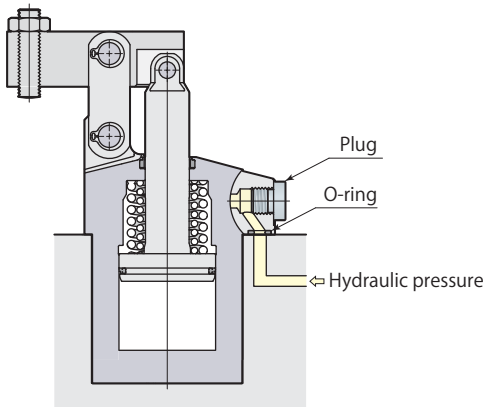

G port piping

Remove plug when choosing G port piping. (O-ring must be used.) Refer to **page →208** for details on G port piping flareless fitting. The flow control valve and the air bleeding valve should be installed in the middle of oil path.

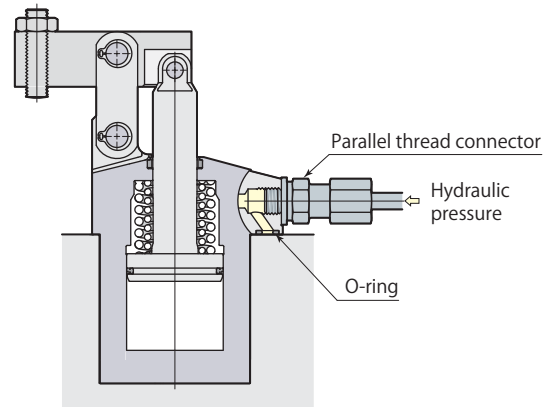

Flow control valve model VCF

Page →154

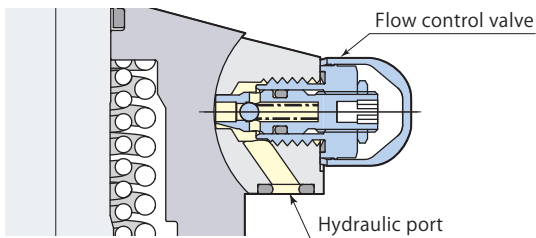

Air bleeding valve model VCE

Page →156

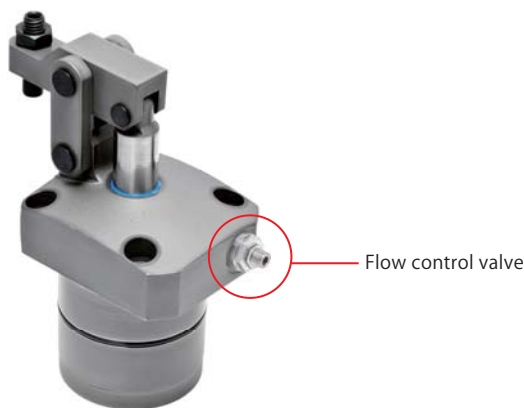
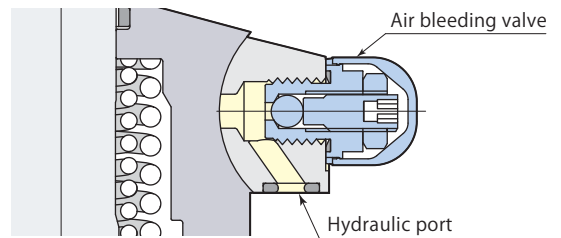

- In case of mounting flow control valve model VCF on the G port of the clamp, air bleeding valve should be installed in the piping to the clamp. (VCE Mounting details. Refer to **page →156**)

Performance diagram

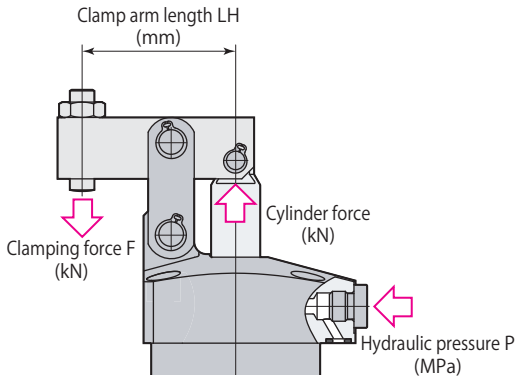

Clamping force varies depending on the clamp arm length (LH) and hydraulic pressure (P).

Clamping force calculation formula

$$F = (\text{Coefficient 1} \times P - \text{Coefficient 2}) / (\text{LH} - \text{Coefficient 3})$$

F: Clamping force P: Hydraulic pressure LH: Clamp arm length

CLN06 with clamp arm length (LH) = 50 mm at hydraulic pressure of 7 MPa, Clamping force F is calculated by  $(18.18 \times 7 - 11.91) / (50 - 21.0) = 4.0 \text{ kN}$

Do not use the clamp in the nonusable range. It may cause damage of link mechanism.

model CLN04

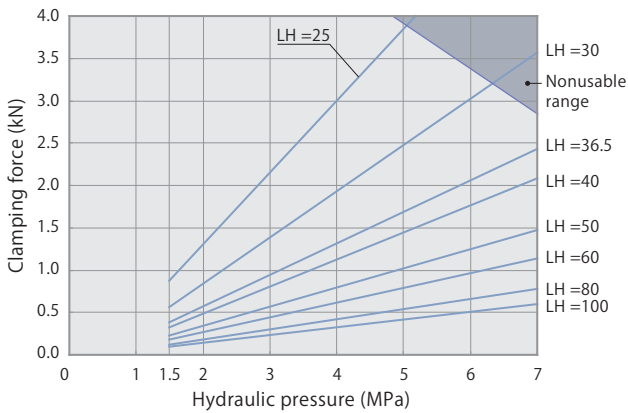

model CLN05

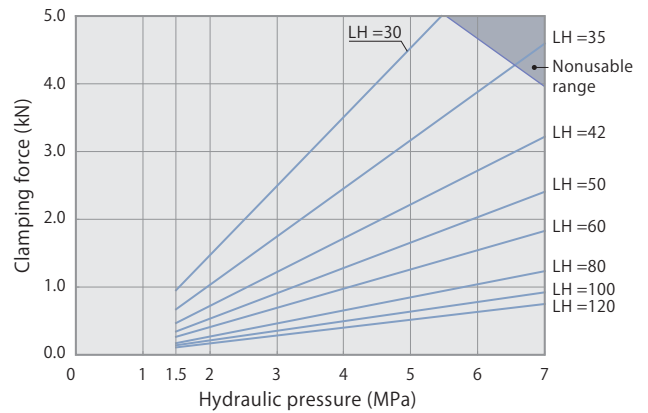

model CLN06

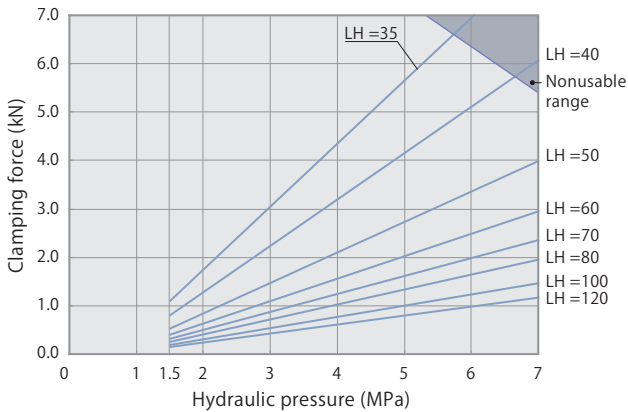

model CLN10

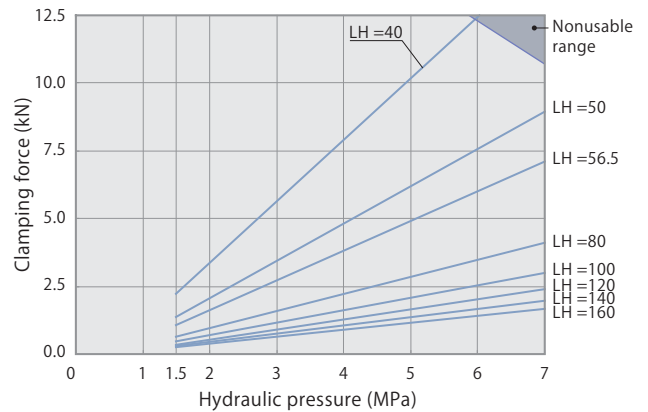

model CLN16

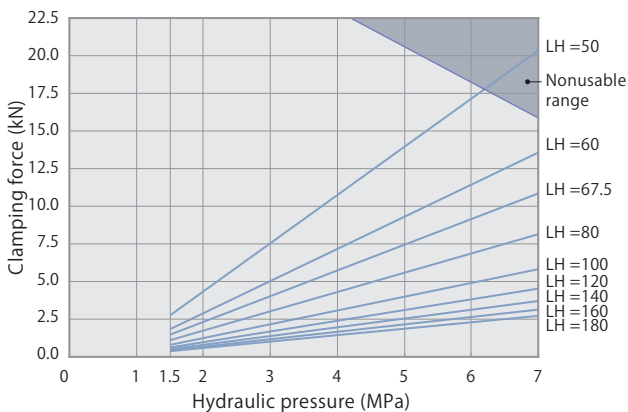

Performance table

**model CLN04** Clamping force  $F=(7.65 \times P-3.63)/(LH-16.0)$

Hydraulic pressure MPa	Cylinder force kN	Clamping force kN								Min. arm length Min. LH mm
		Clamp arm length LH mm								
		25	30	36.5	40	50	60	80	100	
7	3.5			2.4	2.1	1.5	1.1	0.8	0.6	34
6.5	3.2			2.2	1.9	1.4	1.0	0.7	0.5	31
6	2.9		3.0	2.1	1.8	1.2	1.0	0.7	0.5	29
5.5	2.7		2.7	1.9	1.6	1.1	0.9	0.6	0.5	27
5	2.4	3.8	2.5	1.7	1.4	1.0	0.8	0.5	0.4	25
4.5	2.1	3.4	2.2	1.5	1.3	0.9	0.7	0.5	0.4	24
4	1.9	3.0	1.9	1.3	1.1	0.8	0.6	0.4	0.3	↑
3.5	1.6	2.6	1.7	1.1	1.0	0.7	0.5	0.4	0.3	↑
3	1.3	2.1	1.4	0.9	0.8	0.6	0.4	0.3	0.2	↑
2.5	1.1	1.7	1.1	0.8	0.6	0.5	0.4	0.2	0.2	↑
2	0.8	1.3	0.8	0.6	0.5	0.3	0.3	0.2	0.1	↑
1.5	0.5	0.9	0.6	0.4	0.3	0.2	0.2	0.1	0.1	24
Max. pressure MPa		5.0	6.3	7.0	7.0	7.0	7.0	7.0	7.0	

indicates nonusable range

**model CLN05** Clamping force  $F=(11.77 \times P-6.66)/(LH-18.5)$

Hydraulic pressure MPa	Cylinder force kN	Clamping force kN									Min. arm length Min. LH mm
		Clamp arm length LH mm									
		30	35	42	50	60	80	100	120		
7	4.5			3.2	2.4	1.8	1.2	0.9	0.7	38	
6.5	4.2		4.2	3.0	2.2	1.7	1.1	0.9	0.7	35	
6	3.8		3.9	2.7	2.0	1.5	1.0	0.8	0.6	33	
5.5	3.5		3.5	2.5	1.8	1.4	0.9	0.7	0.6	31	
5	3.1	4.5	3.2	2.2	1.7	1.3	0.8	0.6	0.5	29	
4.5	2.8	4.0	2.8	2.0	1.5	1.1	0.8	0.6	0.5	27	
4	2.4	3.5	2.4	1.7	1.3	1.0	0.7	0.5	0.4	↑	
3.5	2.1	3.0	2.1	1.5	1.1	0.8	0.6	0.4	0.3	↑	
3	1.7	2.5	1.7	1.2	0.9	0.7	0.5	0.4	0.3	↑	
2.5	1.4	2.0	1.4	1.0	0.7	0.5	0.4	0.3	0.2	↑	
2	1.0	1.5	1.0	0.7	0.5	0.4	0.3	0.2	0.2	↑	
1.5	0.7	1.0	0.7	0.5	0.3	0.3	0.2	0.1	0.1	27	
Max. pressure MPa		5.4	6.5	7.0	7.0	7.0	7.0	7.0	7.0		

indicates nonusable range

**model CLN06** Clamping force  $F=(18.18 \times P-11.91)/(LH-21.0)$

Hydraulic pressure MPa	Cylinder force kN	Clamping force kN								Min. arm length Min. LH mm
		Clamp arm length LH mm								
		35	40	50	60	70	80	100	120	
7	6.1			4.0	3.0	2.4	2.0	1.5	1.2	43
6.5	5.6		5.6	3.7	2.7	2.2	1.8	1.3	1.1	40
6	5.1		5.1	3.4	2.5	2.0	1.6	1.2	1.0	37
5.5	4.7	6.3	4.6	3.0	2.3	1.8	1.5	1.1	0.9	34
5	4.2	5.6	4.2	2.7	2.0	1.6	1.3	1.0	0.8	32
4.5	3.7	5.0	3.7	2.4	1.8	1.4	1.2	0.9	0.7	31
4	3.2	4.3	3.2	2.1	1.6	1.2	1.0	0.8	0.6	↑
3.5	2.7	3.7	2.7	1.8	1.3	1.1	0.9	0.7	0.5	↑
3	2.3	3.0	2.2	1.5	1.1	0.9	0.7	0.5	0.4	↑
2.5	1.8	2.4	1.8	1.2	0.9	0.7	0.6	0.4	0.3	↑
2	1.3	1.7	1.3	0.8	0.6	0.5	0.4	0.3	0.2	↑
1.5	0.8	1.1	0.8	0.5	0.4	0.3	0.3	0.2	0.2	31
Max. pressure MPa		5.7	6.6	7.0	7.0	7.0	7.0	7.0	7.0	

indicates nonusable range

**model CLN10** Clamping force  $F=(35.07 \times P-17.68)/(LH-24.5)$

Hydraulic pressure MPa	Cylinder force kN	Clamping force kN								Min. arm length Min. LH mm
		Clamp arm length LH mm								
		40	50	56.5	80	100	120	140	160	
7	10.3		8.9	7.1	4.1	3.0	2.4	2.0	1.7	46
6.5	9.5		8.2	6.6	3.8	2.8	2.2	1.8	1.6	43
6	8.7		7.6	6.0	3.5	2.6	2.0	1.7	1.4	41
5.5	7.9	11.3	6.9	5.5	3.2	2.3	1.8	1.5	1.3	38
5	7.1	10.2	6.2	4.9	2.8	2.1	1.6	1.4	1.2	36
4.5	6.3	9.0	5.5	4.4	2.5	1.9	1.5	1.2	1.0	↑
4	5.6	7.9	4.8	3.8	2.2	1.6	1.3	1.1	0.9	↑
3.5	4.8	6.8	4.1	3.3	1.9	1.4	1.1	0.9	0.8	↑
3	4.0	5.6	3.4	2.7	1.6	1.2	0.9	0.8	0.6	↑
2.5	3.2	4.5	2.7	2.2	1.3	0.9	0.7	0.6	0.5	↑
2	2.4	3.4	2.1	1.6	0.9	0.7	0.5	0.5	0.4	↑
1.5	1.6	2.2	1.4	1.1	0.6	0.5	0.4	0.3	0.3	36
Max. pressure MPa		5.9	7.0	7.0	7.0	7.0	7.0	7.0	7.0	

indicates nonusable range

**model CLN16** Clamping force  $F=(64.15 \times P-41.04)/(LH-30.0)$

Hydraulic pressure MPa	Cylinder force kN	Clamping force kN										Min. arm length Min. LH mm
		Clamp arm length LH mm										
		50	60	67.5	80	100	120	140	160	180		
7	15.1		13.6	10.9	8.2	5.8	4.5	3.7	3.1	2.7	54	
6.5	13.9		12.5	10.0	7.5	5.4	4.2	3.4	2.9	2.5	51	
6	12.7	17.2	11.5	9.2	6.9	4.9	3.8	3.1	2.6	2.3	48	
5.5	11.5	15.6	10.4	8.3	6.2	4.5	3.5	2.8	2.4	2.1	45	
5	10.4	14.0	9.3	7.5	5.6	4.0	3.1	2.5	2.2	1.9	43	
4.5	9.2	12.4	8.3	6.6	5.0	3.5	2.8	2.3	1.9	1.7	↑	
4	8.0	10.8	7.2	5.7	4.3	3.1	2.4	2.0	1.7	1.4	↑	
3.5	6.8	9.2	6.1	4.9	3.7	2.6	2.0	1.7	1.4	1.2	↑	
3	5.6	7.6	5.0	4.0	3.0	2.2	1.7	1.4	1.2	1.0	↑	
2.5	4.4	6.0	4.0	3.2	2.4	1.7	1.3	1.1	0.9	0.8	↑	
2	3.2	4.4	2.9	2.3	1.7	1.2	1.0	0.8	0.7	0.6	↑	
1.5	2.0	2.8	1.8	1.5	1.1	0.8	0.6	0.5	0.4	0.4	43	
Max. pressure MPa		5.8	7.0	7.0	7.0	7.0	7.0	7.0	7.0	7.0		

indicates nonusable range





## Unclamp PAL sensor function and structure

### Unclamp detection

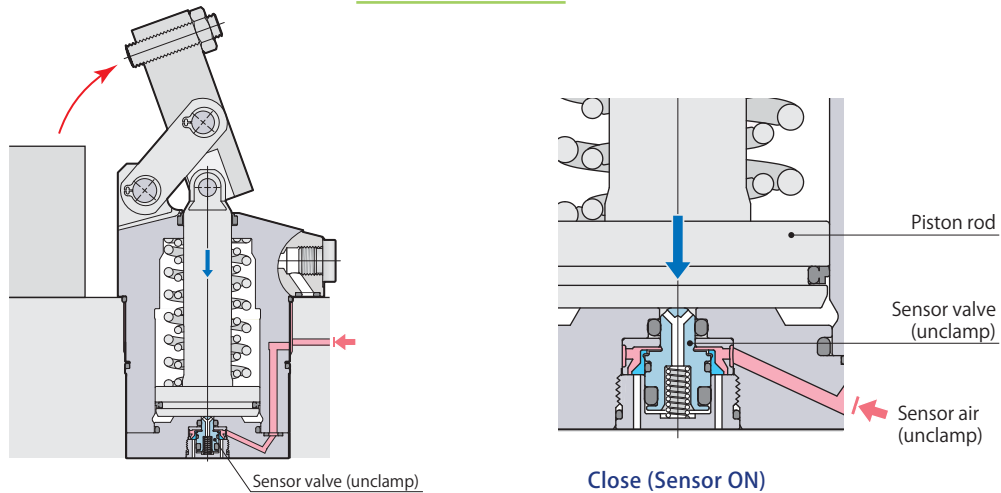

- The sensor valve (unclamp) is pushed down by the piston rod and shuts off the sensor air flow when the piston rod reaches the unclamp end, and detects the unclamped condition.

### In the middle of clamp stroke

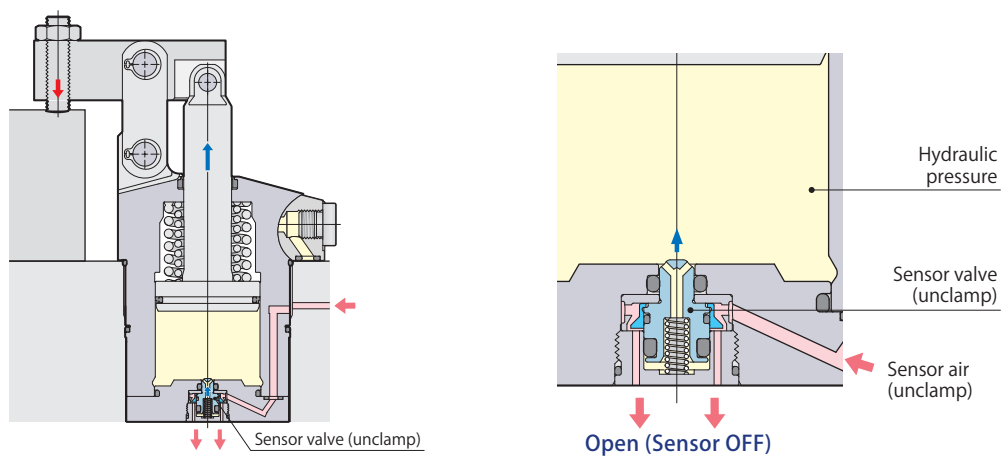

- The sensor valve (unclamp) is pushed up by the hydraulic force to open for air exhaust while piston rod strokes.

Unclamp detection signal

Unclamp detection

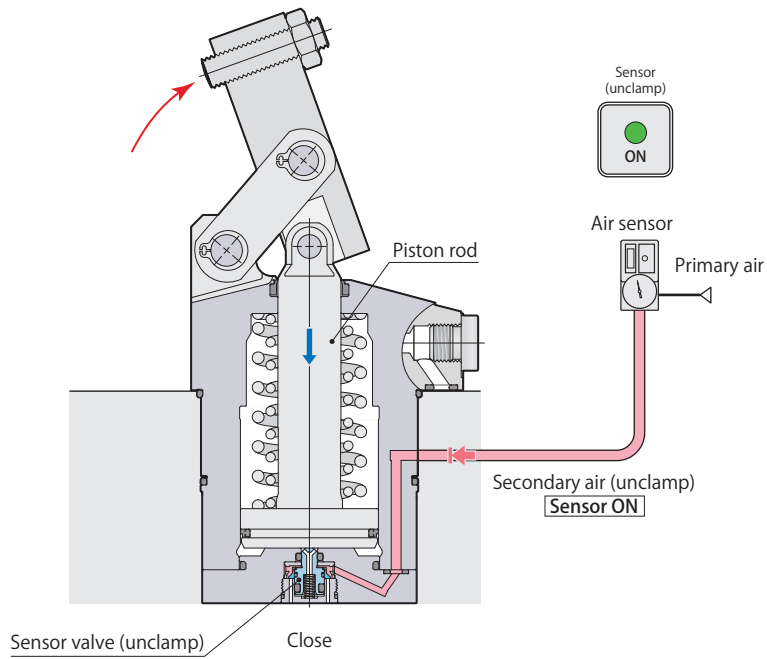

Sensor signal (unclamp)	ON	Unclamp
-------------------------	----	---------

In the middle of clamp stroke

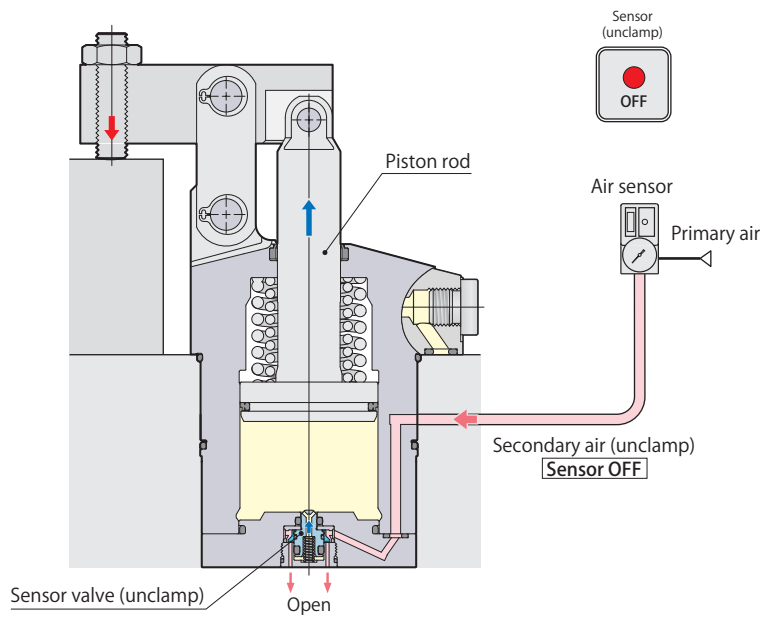

Sensor signal (unclamp)	OFF	Clamp, in the middle of clamp stroke
-------------------------	-----	--------------------------------------

Single acting Link clamp Sensing CLN-B Unclamp sensor model

### Air sensor triggering point

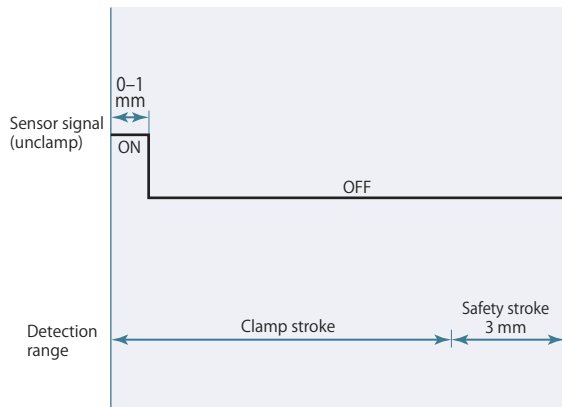

- Refer to the sensor supplier's instruction manual for the details of setting.
- Sensing performance such as detectable time and pressure differs depending on the supplier and model number of the sensor. Select the right model referring to sensor's application and characteristics.

### Air sensor recommended condition of use

Supplier and model	ISA3-F/G series manufactured by SMC GPS2-05, GPS3-E series manufactured by CKD
Air supply pressure	0.1–0.2 MPa
Inner diameter of piping	ø4 mm (ISA3-F:ø2.5 mm)
Overall piping length	5 m or less

- Supply the dry and filtered air. Particulate size  $5\ \mu\text{m}$  or less is recommended.
- Use a solenoid valve with needle for air sensor unit and control it supplying air all the time in order to eliminate intrusion of chips or coolant.
- There is a case that air sensing cannot be successfully made as designed when it is used out of the above usage. Contact Technical service center for more details.

### Relation between sensor air pressure, PAL sensor and piston stroke

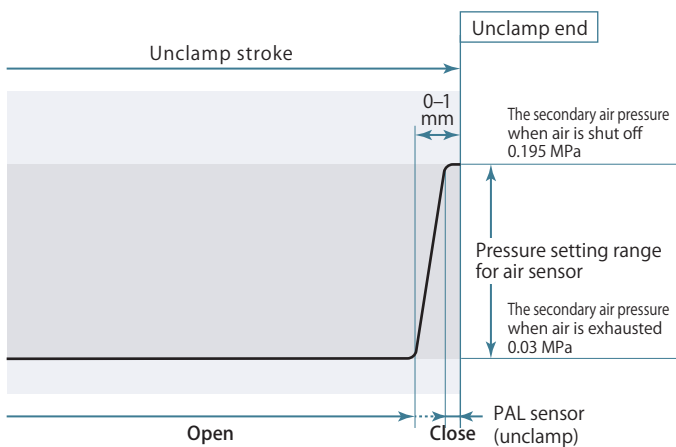

The diagram shown above indicates the relation between the PAL sensor, piston stroke, and secondary air pressure. (The pressure shown in the diagram is a reference based on the 0.2 MPa of primary air pressure for one piece of clamp.)

Since the new PAL sensor works with less air-leakage compared to previous sensor valve,

- Enhances the pressure setting range of the sensor which enables the sensor to set easily. (Ex. Pressure setting range 0.03–0.195 MPa in the diagram)
- Allows the use for a number of clamps by one air sensor because of better pressure holding when air is shut off. (Maximum number of clamps to be detected by one sensor is 10.)
- Allows to choose less air-consumed, i.e. small orifice diameter type, air sensor.
- Can create large differential-pressure when opening and closing the PAL sensor so that sensor primary pressure can be set as low as possible and reduce the consumption of air.

New PAL sensor

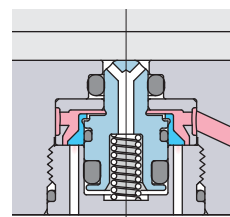

Poppet structure ensures superior sealing performance and can create large differential-pressure when the valve is opening and closing, and air leakage can be minimized.

Previous sensor valve

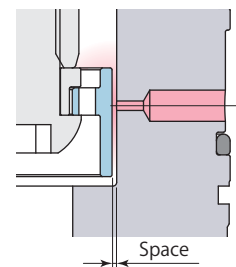

Air leaks easily due to a large space.

Dimensions

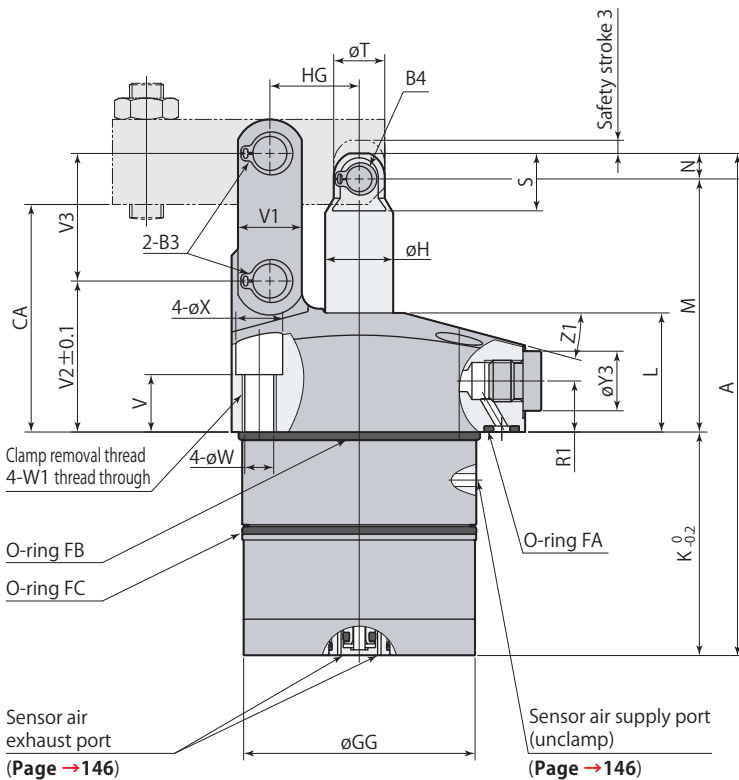
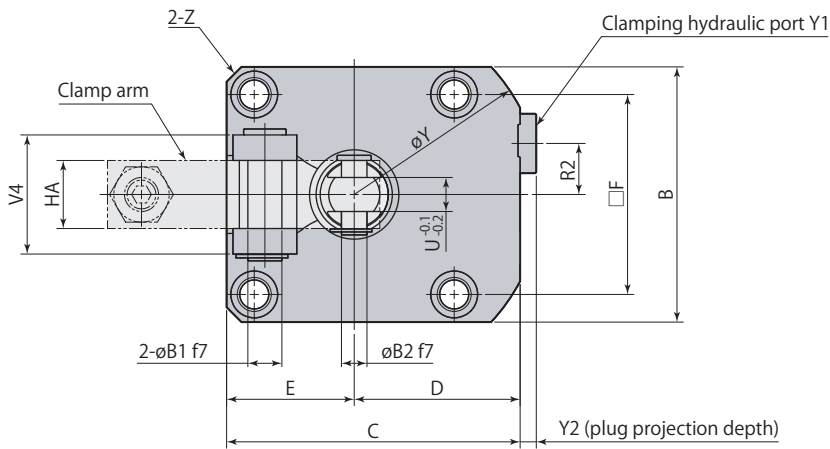

Clamp

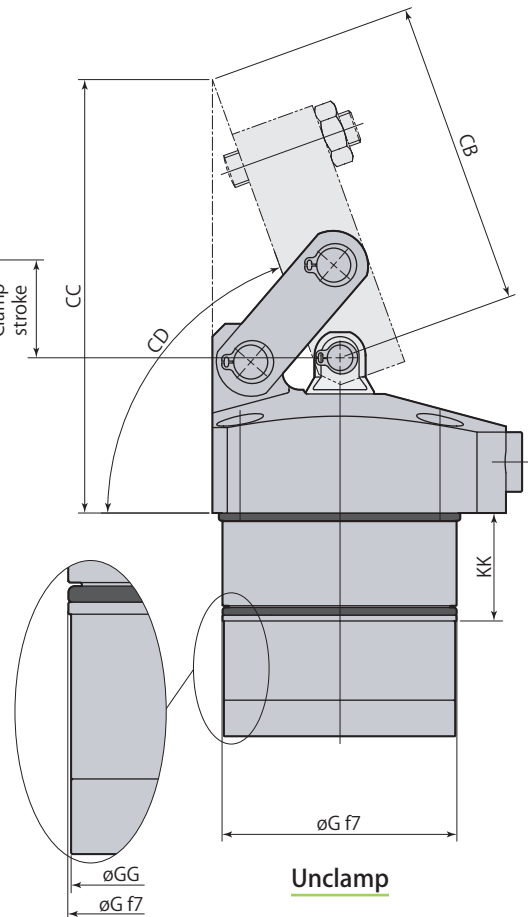

Unclamp

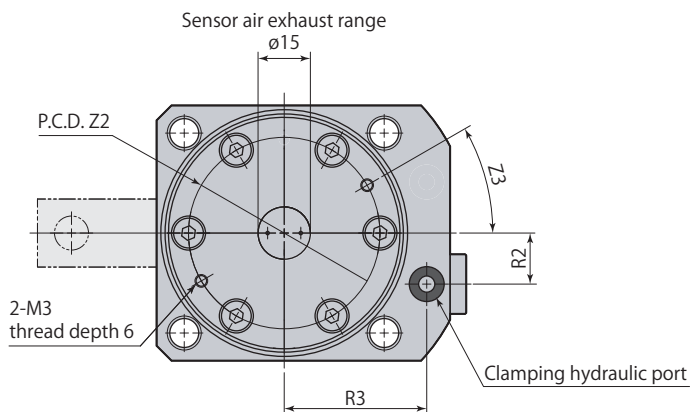

● This diagram represents external contour of CLN □-F. CLN□-L and CLN□-R differ only in terms of mounting direction of clamp arm and otherwise all dimensions are identical to those of CLN□-F.

L: Left side F: Front side R: Right side

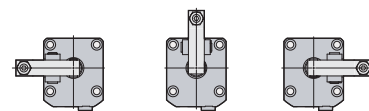

● Clamp arm and mounting screws are not included.

<b>CLN□-□B</b>	<b>Single acting Link clamp Unclamp sensor model</b>	<b>7MPa</b>	<b>Single acting</b>
----------------	--	-------------	----------------------

Model	CLN04-□B	CLN05-□B	CLN06-□B	CLN10-□B	CLN16-□B
A	92.5	104.5	118	132.5	158
B	45	51	60	70	85
C	54	61	69	81	94.5
D	31.5	35.5	39	46	52
E	22.5	25.5	30	35	42.5
F	34	40	47	55	63
øG	40 <sup>-0.025 -0.050</sup>	48 <sup>-0.025 -0.050</sup>	55 <sup>-0.030 -0.060</sup>	65 <sup>-0.030 -0.060</sup>	75 <sup>-0.030 -0.060</sup>
øGG	39.4	47.4	54.4	64.4	74.4
øH	12	14	16	20	22
K	37	41.5	52.5	57.5	66
KK	25	25	25	25	25
L	25	28	28	30	37
M	50	57	59.5	67	82
N	5.5	6	6	8	10
R1	11	12	12	13	14
R2	9	11	12	15	16
R3	26	30	33.5	39.5	45
S	12.5	13.5	13.5	17.5	22
øT	11	12	12	15	19
U (width across flats)	6	6	8	10	11
V	15.5	16.5	13.5	15.5	17.5
V1	11	13	15	19	25
V2	30.5	34.5	35.5	39	48
V3	22	26	30	35.5	43.5
V4	21	21	28	37	40
øW	5.5	5.5	6.8	6.8	9
W1	M6×1	M6×1	M8×1.25	M8×1.25	M10×1.5
øX	9.5	9.5	11	11	14
øY	72	81	88	106	116
Y1	G1/8	G1/8	G1/8	G1/4	G1/4
Y2	3.8	3.8	3.8	4.8	4.8
øY3	14	14	14	19	19
Z	C3	C3	C3.5	C4.5	C10
Z1	15°	15°	15°	12°	15°
Z2	32	38	45	53.5	63.5
Z3	30°	30°	30°	30°	45°
øB1	6 <sup>-0.010 -0.022</sup>	6 <sup>-0.010 -0.022</sup>	8 <sup>-0.013 -0.028</sup>	10 <sup>-0.013 -0.028</sup>	12 <sup>-0.016 -0.034</sup>
øB2	6 <sup>-0.010 -0.022</sup>	6 <sup>-0.010 -0.022</sup>	6 <sup>-0.010 -0.022</sup>	8 <sup>-0.013 -0.028</sup>	10 <sup>-0.013 -0.028</sup>
B3 (snap ring)*1	STW-6	STW-6	STW-8	STW-10	STW-12
B4 (snap ring)*1	STW-6	STW-6	STW-6	STW-8	STW-10
CA	44.5	51	53.5	59	72
CB	50.2	61.2	71.7	78.7	90.8
CC	77.7	92.4	101.9	111.4	130.8
CD	About 70°	About 71°	About 70°	About 70°	About 69°
HA	12	12	16	19	22
HG	16	18.5	21	24.5	30
O-ring FA (fluorocarbon hardness Hs90)	P5	P5	P5	P7	P7
O-ring FB (fluorocarbon hardness Hs70)	AS568-029	AS568-031	AS568-034	AS568-037	AS568-040
O-ring FC (fluorocarbon hardness Hs70)	AS568-028	AS568-031	AS568-033	AS568-036	AS568-039
Flow control valve (meter-in)*2	VCF01S	VCF01	VCF01	VCF02	VCF02
Air bleeding valve*2	VCE01	VCE01	VCE01	VCE02	VCE02

\*1: Snap ring is made by Ochiai Corporation.

\*2: Select the right model of VCF and VCE according to the size of the clamp.

Refer to each page for the details of options.

● Flow control valve **page →154**

● Air bleeding valve **page →156**

mm

Mounting details

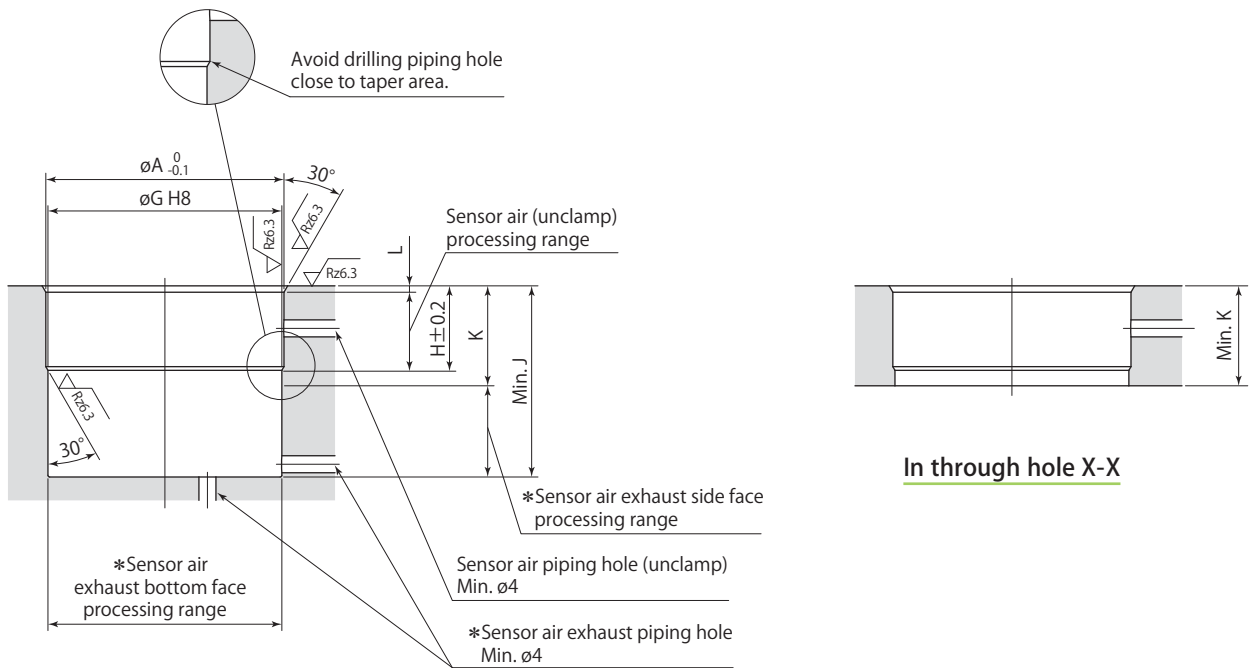
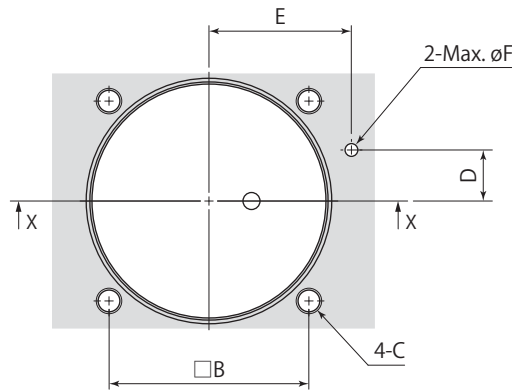

In blind hole X-X

\*: Sensor air exhaust piping hole must be made on either side or bottom face.

Rz: ISO4287(1997)

- Apply an appropriate amount of grease to the chamfer and the bore when mounting. Excessive grease may be a blockage in the air passage, causing malfunction of the sensor.
- The 30° taper machining must be provided to avoid the damage of the O-ring. Ensure that there are no interference on taper area when drilling the hole for sensor air.

### Mounting details

Model	CLN04-□B	CLN05-□B	CLN06-□B	CLN10-□B	CLN16-□B
øA	40.8	49	56	66	76
B	34	40	47	55	63
C	M5	M5	M6	M6	M8
D	9	11	12	15	16
E	26	30	33.5	39.5	45
øF	3	3	3	5	5
øG	40 <sup>+0.039</sup> <sub>0</sub>	48 <sup>+0.039</sup> <sub>0</sub>	55 <sup>+0.046</sup> <sub>0</sub>	65 <sup>+0.046</sup> <sub>0</sub>	75 <sup>+0.046</sup> <sub>0</sub>
H	20.5	20.5	20.5	20.5	20.5
J	37.5	42	53	58	66.5
K	25	25	25	25	25
L	1.2	1.5	1.5	1.5	1.5

### Caution for piping

Refer to the diagram shown below for the sensor air exhaust port.

Mounting in blind hole  
(Sensor air exhaust : side face)

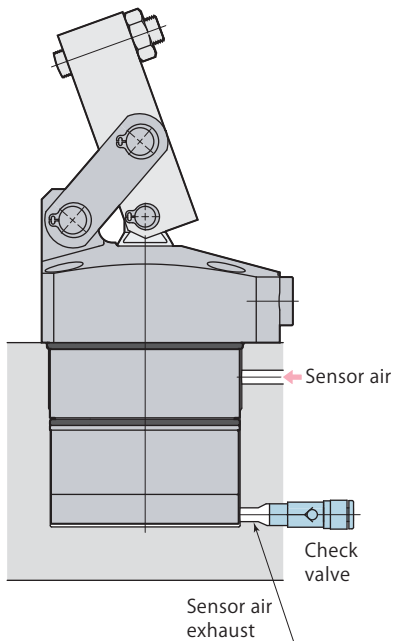

Mounting in blind hole  
(Sensor air exhaust : bottom face)

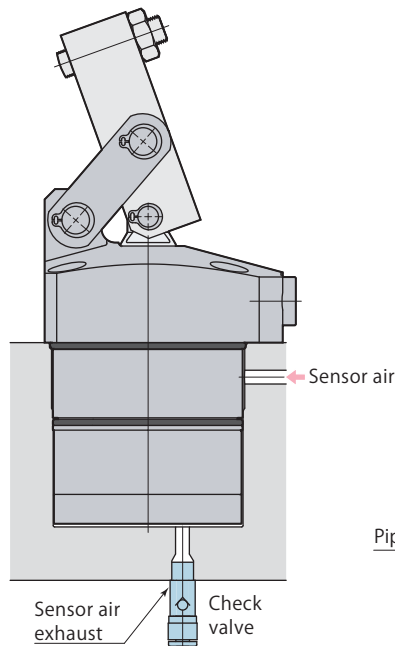

Mounting in through hole

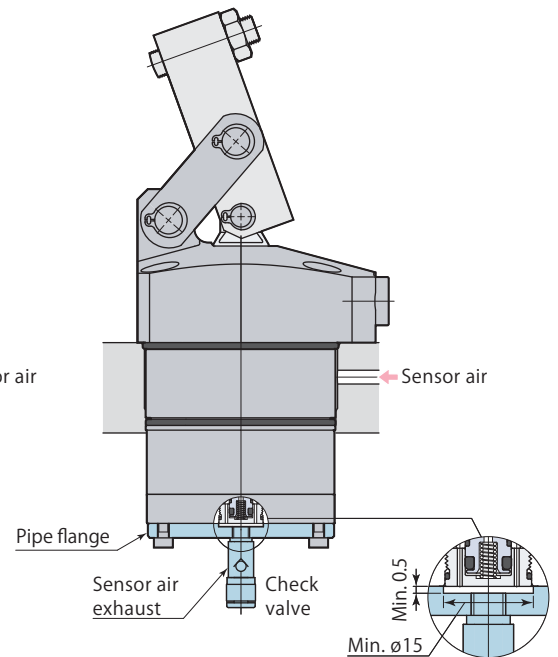

- Use a check valve with cracking pressure of 0.005 MPa or less if there is a risk of metal chips or coolant intrusion. Recommended check valve : AKH or AKB series manufactured by SMC.
- Furnish the piping by means of the pipe flange when mounting in a through hole. The flange is mountable with M3 threads at the bottom of the clamp. Be sure to provide an opening not to cover the exhaust port. See the sketch shown above.

Dimensions

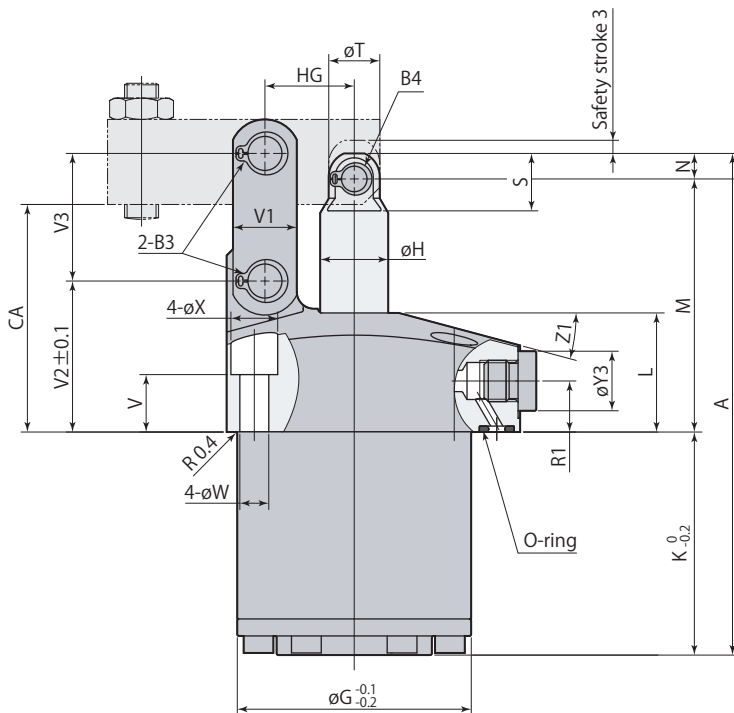
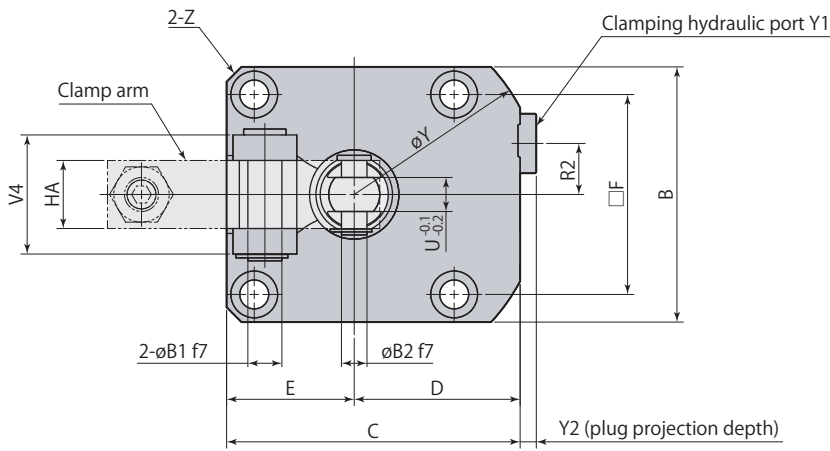

Clamp

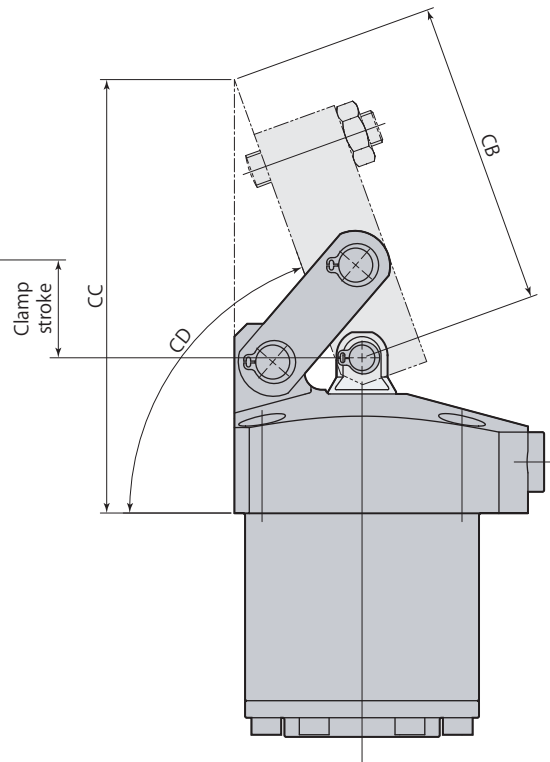

Unclamp

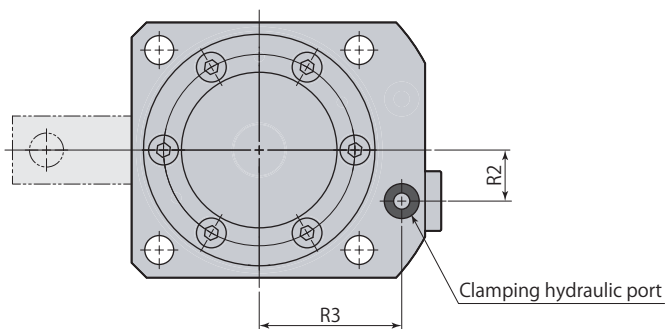

● This diagram represents external contour of CLN □-F. CLN□-L and CLN□-R differ only in terms of mounting direction of clamp arm and otherwise all dimensions are identical to those of CLN□-F.

L: Left side F: Front side R: Right side

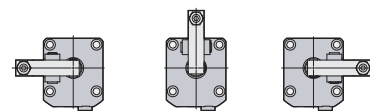

● Clamp arm and mounting screws are not included.



<b>CLN□-□N</b>	<b>Single acting Link clamp Compact model</b>	<b>7MPa</b>	<b>Single acting</b>
----------------	---	-------------	----------------------

Model	CLN04-□N	CLN05-□N	CLN06-□N	CLN10-□N	CLN16-□N
A	92.5	104.5	118	132.5	158
B	45	51	60	70	85
C	54	61	69	81	94.5
D	31.5	35.5	39	46	52
E	22.5	25.5	30	35	42.5
F	34	40	47	55	63
øG	40	48	55	65	75
øH	12	14	16	20	22
K	37	41.5	52.5	57.5	66
L	25	28	28	30	37
M	50	57	59.5	67	82
N	5.5	6	6	8	10
R1	11	12	12	13	14
R2	9	11	12	15	16
R3	26	30	33.5	39.5	45
S	12.5	13.5	13.5	17.5	22
øT	11	12	12	15	19
U (width across flats)	6	6	8	10	11
V	15.5	16.5	13.5	15.5	17.5
V1	11	13	15	19	25
V2	30.5	34.5	35.5	39	48
V3	22	26	30	35.5	43.5
V4	21	21	28	37	40
øW	5.5	5.5	6.8	6.8	9
øX	9.5	9.5	11	11	14
øY	72	81	88	106	116
Y1	G1/8	G1/8	G1/8	G1/4	G1/4
Y2	3.8	3.8	3.8	4.8	4.8
øY3	14	14	14	19	19
Z	C3	C3	C3.5	C4.5	C10
Z1	15°	15°	15°	12°	15°
øB1	6 <sup>-0.010</sup> <sub>-0.022</sub>	6 <sup>-0.010</sup> <sub>-0.022</sub>	8 <sup>-0.013</sup> <sub>-0.028</sub>	10 <sup>-0.013</sup> <sub>-0.028</sub>	12 <sup>-0.016</sup> <sub>-0.034</sub>
øB2	6 <sup>-0.010</sup> <sub>-0.022</sub>	6 <sup>-0.010</sup> <sub>-0.022</sub>	6 <sup>-0.010</sup> <sub>-0.022</sub>	8 <sup>-0.013</sup> <sub>-0.028</sub>	10 <sup>-0.013</sup> <sub>-0.028</sub>
B3 (snap ring)*1	STW-6	STW-6	STW-8	STW-10	STW-12
B4 (snap ring)*1	STW-6	STW-6	STW-6	STW-8	STW-10
CA	44.5	51	53.5	59	72
CB	50.2	61.2	71.7	78.7	90.8
CC	77.7	92.4	101.9	111.4	130.8
CD	About 70°	About 71°	About 70°	About 70°	About 69°
HA	12	12	16	19	22
HG	16	18.5	21	24.5	30
O-ring (fluorocarbon hardness Hs90)	P5	P5	P5	P7	P7
Flow control valve (meter-in)*2	VCF01S	VCF01	VCF01	VCF02	VCF02
Air bleeding valve*2	VCE01	VCE01	VCE01	VCE02	VCE02

\*1: Snap ring is made by Ochiai Corporation.

\*2: Select the right model of VCF and VCE according to the size of the clamp.

Refer to each page for the details of options.

● Flow control valve **page →154**

● Air bleeding valve **page →156**

Single acting  
Link clamp

CLN-N  
Compact model

Mounting details

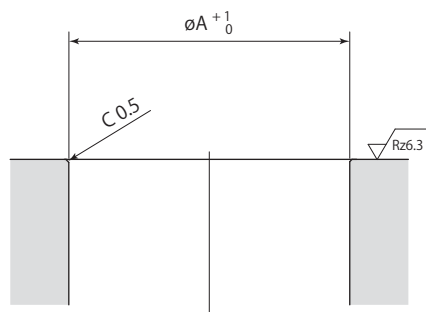
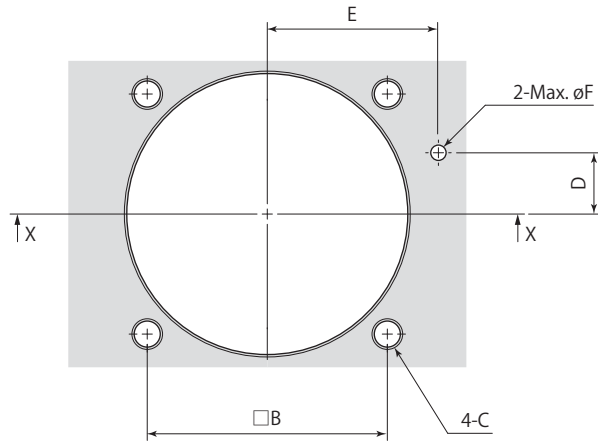

X-X

Rz: ISO4287(1997)

mm

Model	CLN04-□N	CLN05-□N	CLN06-□N	CLN10-□N	CLN16-□N
øA	40	48	55	65	75
B	34	40	47	55	63
C	M5	M5	M6	M6	M8
D	9	11	12	15	16
E	26	30	33.5	39.5	45
øF	3	3	3	5	5

Clamp arm mounting details

Clamp arm is not included. Manufacture a clamp arm with the dimensions shown in the table below.

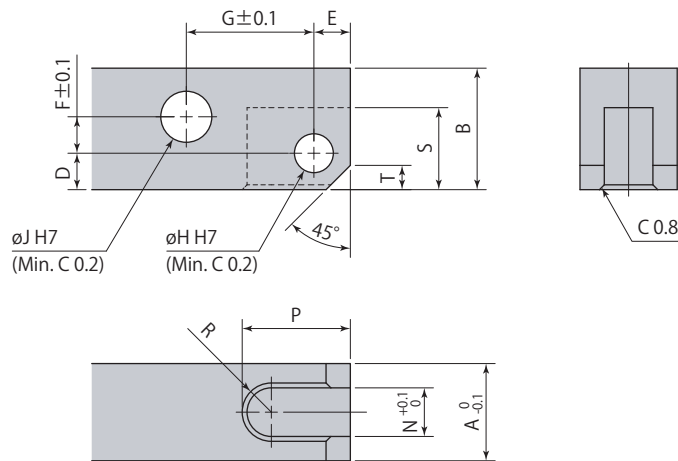

Recommended material: S45C (HB167–229)

Link clamp	CLN04	CLN05	CLN06	CLN10	CLN16
A	12	12	16	19	22
B	14	16	20	25	32
D	5.5	6	6	8	10
E	5.5	6	6	7	10
F	2.5	3.5	6	7.5	9.5
G	16	18.5	21	24.5	30
øH	6 <sup>+0.012</sup> <sub>0</sub>	6 <sup>+0.012</sup> <sub>0</sub>	6 <sup>+0.012</sup> <sub>0</sub>	8 <sup>+0.015</sup> <sub>0</sub>	10 <sup>+0.015</sup> <sub>0</sub>
øJ	6 <sup>+0.012</sup> <sub>0</sub>	6 <sup>+0.012</sup> <sub>0</sub>	8 <sup>+0.015</sup> <sub>0</sub>	10 <sup>+0.015</sup> <sub>0</sub>	12 <sup>+0.018</sup> <sub>0</sub>
N	6	6	8	10	11
P	14.5	17	17	20	25.5
R	R3	R3	R4	R5	R5.5
S	12	13.5	13.5	17.5	22
T	3	4	4	5	8

● When mounting the clamp arm, use included pins and snap rings.

Clamp arm allowable eccentricity

An eccentric shape clamp arm, as shown in diagram on right can be used with link clamp model CLN, if it is not possible to set clamping point at tip section of clamp arm in alignment with center line of piston rod and clamp arm.

Amount of eccentricity, however, must be within allowable eccentricity shown below.

Using a clamp arm that exceeds allowable eccentricity results in significant eccentric load on link mechanism and piston rod, leading to malfunction.

Eccentric shape clamp arm

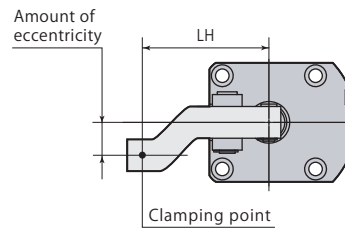

Ordinary clamp arm

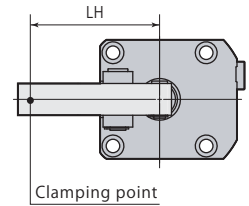

model CLN04		indicates nonusable range						
Hydraulic pressure MPa	Allowable eccentricity mm							
	Clamp arm length LH mm							
	25	30	36.5	40	50	60	80	100
7			14	17	26	36	54	60
6.5			16	21	32	44	60	↑
6		10	19	24	39	53	↑	↑
5.5		12	22	28	45	60	↑	↑
5	6	15	27	33	52	↑	↑	↑
4.5	8	18	32	39	60	↑	↑	↑
4	11	23	39	47	↑	↑	↑	↑
3.5	15	29	48	58	↑	↑	↑	↑
3	20	38	60	60	↑	↑	↑	↑
2.5	28	50	↑	↑	↑	↑	↑	↑
2	42	60	↑	↑	↑	↑	↑	↑
1.5	60	60	60	60	60	60	60	60

model CLN05		indicates nonusable range						
Hydraulic pressure MPa	Allowable eccentricity mm							
	Clamp arm length LH mm							
	30	35	42	50	60	80	100	120
7			6	6	10	17	25	32
6.5		6	6	10	14	24	34	44
6		6	9	14	21	33	45	58
5.5		6	13	20	28	43	58	60
5	6	8	17	26	36	56	60	↑
4.5	6	11	21	32	45	60	↑	↑
4	7	15	26	39	54	↑	↑	↑
3.5	11	20	33	48	60	↑	↑	↑
3	15	27	43	60	↑	↑	↑	↑
2.5	23	38	58	↑	↑	↑	↑	↑
2	35	56	60	↑	↑	↑	↑	↑
1.5	60	60	60	60	60	60	60	60

model CLN06		indicates nonusable range						
Hydraulic pressure MPa	Allowable eccentricity mm							
	Clamp arm length LH mm							
	35	40	50	60	70	80	100	120
7			8	8	8	8	8	8
6.5		8	9	15	17	20	24	26
6		8	14	21	28	32	41	49
5.5	8	11	20	29	38	47	60	73
5	10	15	27	39	50	62	80	80
4.5	14	22	36	51	66	80	↑	↑
4	20	30	49	68	80	↑	↑	↑
3.5	28	41	66	80	↑	↑	↑	↑
3	38	56	80	↑	↑	↑	↑	↑
2.5	53	76	↑	↑	↑	↑	↑	↑
2	78	80	↑	↑	↑	↑	↑	↑
1.5	80	80	80	80	80	80	80	80

model CLN10		indicates nonusable range						
Hydraulic pressure MPa	Allowable eccentricity mm							
	Clamp arm length LH mm							
	40	50	56.5	80	100	120	140	160
7		9	9	15	23	31	39	46
6.5		9	10	22	33	44	55	65
6		10	15	31	46	59	74	88
5.5	9	15	21	42	60	79	95	95
5	9	21	29	56	79	95	↑	↑
4.5	11	29	39	74	95	↑	↑	↑
4	16	39	52	95	↑	↑	↑	↑
3.5	22	49	66	↑	↑	↑	↑	↑
3	31	64	85	↑	↑	↑	↑	↑
2.5	45	86	95	↑	↑	↑	↑	↑
2	68	95	↑	↑	↑	↑	↑	↑
1.5	95	95	95	95	95	95	95	95

model CLN16		indicates nonusable range								
Hydraulic pressure MPa	Allowable eccentricity mm									
	Clamp arm length LH mm									
	50	60	69.5	80	100	120	140	160	180	
7		13	23	35	55	68	81	94	106	
6.5		16	28	41	65	89	107	110	110	
6	7	20	33	47	74	102	110	↑	↑	
5.5	11	25	40	55	86	110	↑	↑	↑	
5	14	31	47	65	100	↑	↑	↑	↑	
4.5	19	39	57	78	110	↑	↑	↑	↑	
4	25	48	70	94	↑	↑	↑	↑	↑	
3.5	34	62	88	110	↑	↑	↑	↑	↑	
3	47	80	110	↑	↑	↑	↑	↑	↑	
2.5	66	110	↑	↑	↑	↑	↑	↑	↑	
2	100	↑	↑	↑	↑	↑	↑	↑	↑	
1.5	110	110	110	110	110	110	110	110	110	