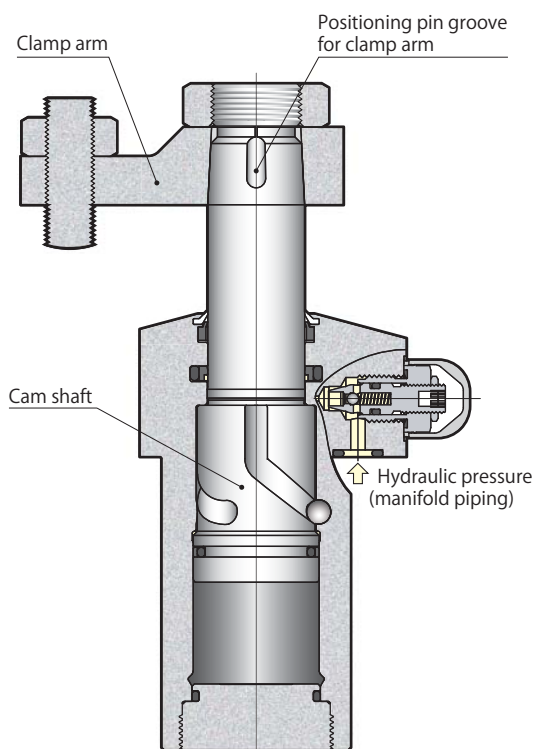
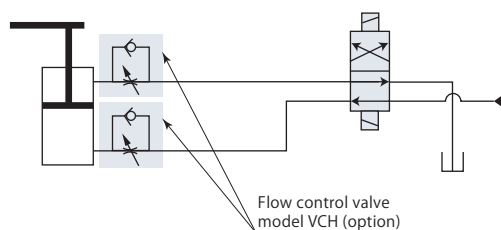

Upper flange

model CTK□□-□

Hydraulic circuit diagram

For flow control valve, we recommend the meter-in control. If meter-out control is used, due to the area difference, it will cause back pressure and become high pressure. This can lead to malfunction of the system. Please be aware when designing the circuit.

Specifications	page → 3
Upper flange	page → 8
Lower flange	page → 12
Cartridge	page → 16
Pin rod	page → 20
Swing angle 30°, 45°, 60°	page → 22
Long stroke	page → 26

Specifications

Size	Mounting and piping types	Swing direction (when clamping), swing angle
CTK	U : Upper flange B : Lower flange N : Cartridge	L : Counter-clockwise, swing angle 90°
		L30 : Counter-clockwise, swing angle 30°
		L45 : Counter-clockwise, swing angle 45°
		L60 : Counter-clockwise, swing angle 60°
		R : Clockwise, swing angle 90°
		R30 : Clockwise, swing angle 30°
		R45 : Clockwise, swing angle 45°
		R60 : Clockwise, swing angle 60°
		C : Straight, swing angle 0°

■ indicates made to order.

Refer to pages → 20 and 21 for details of pin rod (CTK□□-□P).

Refer to pages → 26 and 27 for details of long stroke of upper flange (CTK□U-□J).

Refer to pages → 28 to 37 for details of sensor model (CTK□U-□C, CTK□U-□B).

Mounting and piping types

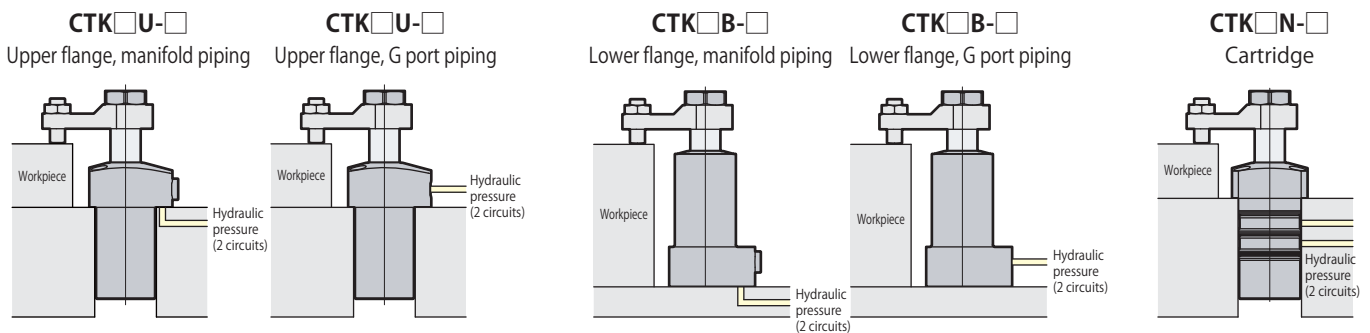

Refer to page → 5 for details of piping methods.
 Only manifold piping is available for model CTK02.

Swing direction (when clamping)

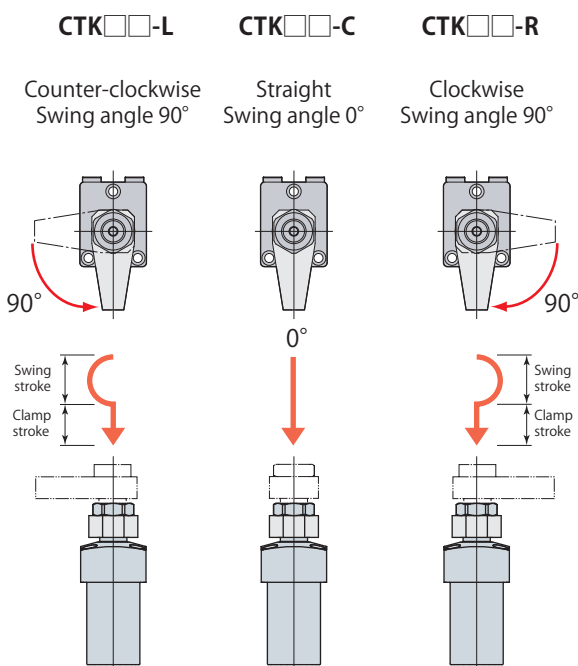

Swing angle

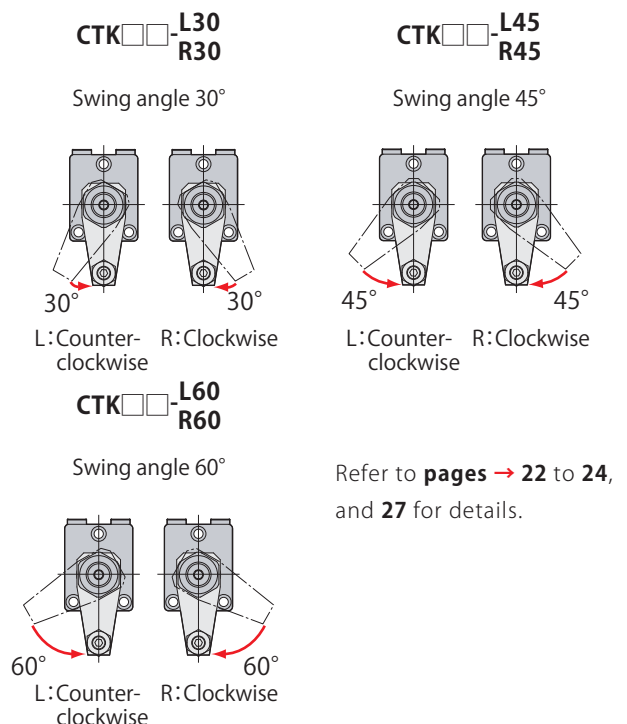

Specifications

Model		CTK02	CTK04	CTK06	CTK10	CTK16	
Cylinder force (hydraulic pressure 35MPa)	kN	3.1	5.1	7.6	14.6	20.3	
Cylinder inner diameter	mm	16	21	26	34	42	
Rod diameter	mm	12	16	20	25	32	
Effective area (clamp)	cm ²	0.88	1.45	2.17	4.17	5.81	
Swing angle	CTK□□-L, R	90° ± 3°					
	CTK□□-C	0°					
Positioning pin groove position accuracy		± 1°					
Repeated clamp positioning accuracy		± 0.5°					
Full stroke	mm	15	17	21	25.5	28.5	
90° swing stroke (CTK□□-L, R)	mm	7	9	11	13.5	16.5	
Clamp stroke (CTK□□-L, R)	mm	8	8	10	12	12	
Cylinder capacity	Clamp	cm ³	1.3	2.5	4.6	10.6	16.6
	Unclamp	cm ³	3.0	5.9	11.1	23.2	39.5
Mass	kg	0.4	0.7	1.1	2.0	3.3	
Recommended tightening torque of mounting screws*	N·m	7	7	12	29	57	
Recommended tightening torque of nut	N·m	11	26	51	75	130	

● Pressure range: 5–35 MPa ● Proof pressure: 52.5 MPa ● Operating temperature: 0–70°C

● Fluid used: General mineral based hydraulic oil (ISO-VG32 equivalent)

● Seals are resistant to chlorine-based cutting fluid. (not thermal resistant specification)

● There is no overload protection mechanism.

*: ISO R898 class 12.9

Clamping must be done within the range of clamp stroke.

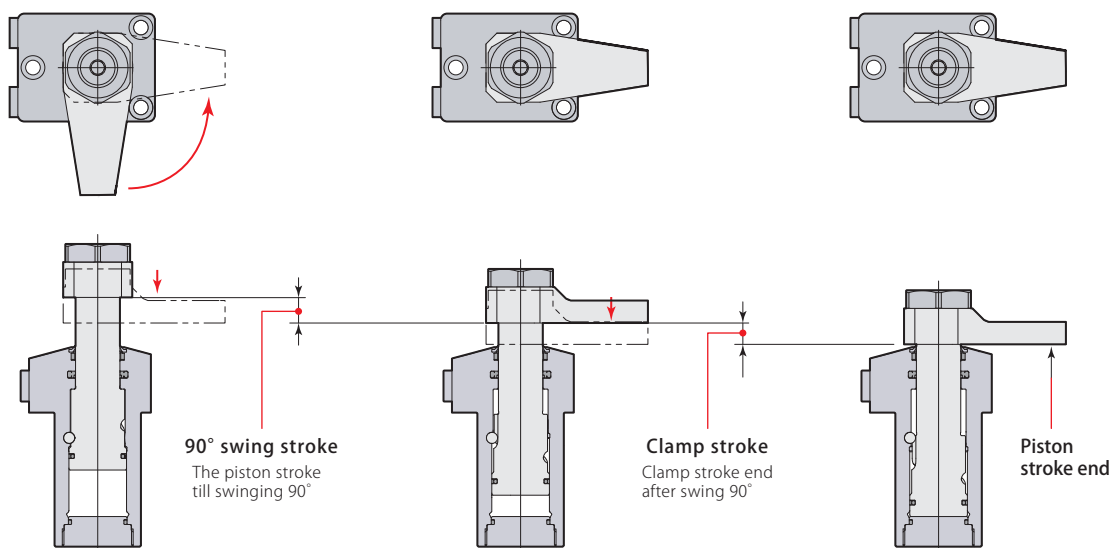

Manifold piping and G port piping are available.

Two piping methods are available for model CTK□□U-□ (upper flange) and model CTK□□B-□ (lower flange), manifold piping and G port piping.

Manifold piping

When choosing manifold piping, a flow control valve (model VCH) and an air bleeding valve (model VCE) are mountable on the G ports of the clamp. Only manifold piping is available for model CTK02.

G port piping

Remove plugs when choosing G port piping for model CTK□□U-□ (upper flange). (O-ring must be used.) Remove plugs and O-ring, and mount sealing plug that is included, when choosing G port piping for model CTK□□B-□ (lower flange). (Sealing plug is not mounted with shipment.) The flow control valve and the air bleeding valve should be installed in the middle of oil path.

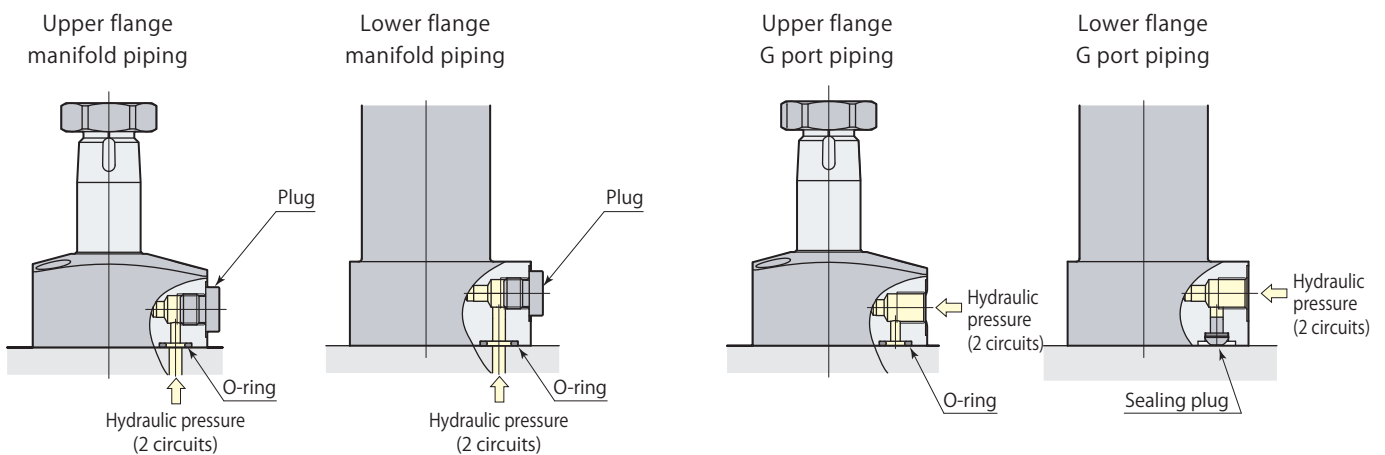

Flow control valve model VCH

Page →44

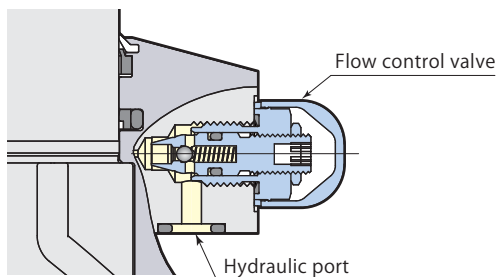

Air bleeding valve model VCE

Page →46

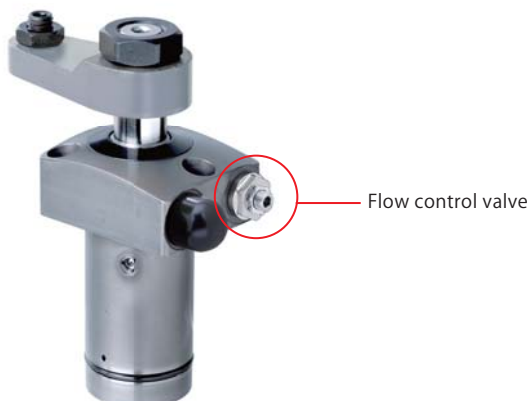
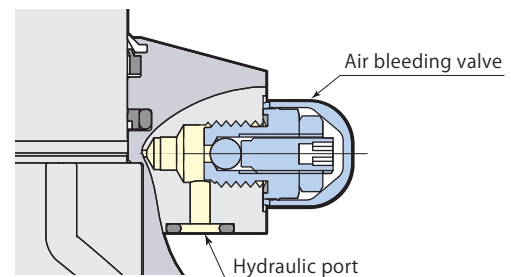

Performance table

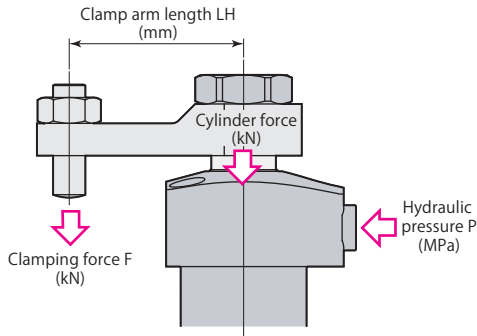

Clamping force varies depending on the clamp arm length (LH) and hydraulic pressure (P).

Clamping force calculation formula

$$F = P / (\text{Coefficient 1} + \text{Coefficient 2} \times LH)$$

F: Clamping force P: Hydraulic pressure LH: Clamp arm length

CTK06 with clamp arm length (LH) = 80 mm at hydraulic pressure of 20 MPa, Clamping force F is calculated by $20 / (4.61 + 0.0185 \times 80) = 3.3$ kN

Do not use the clamp in the nonusable range. It may cause damage to the cylinder and rod.

model CTK02		Clamping force $F = P / (11.4 + 0.0625 \times LH)$										
Hydraulic pressure MPa	Cylinder force kN	Clamping force kN										Max. arm length Max. LH mm
		Clamp arm length LH mm										
		20	25	30	35	40	45	50	60	70	80	
35	3.1	2.8	2.7									27
30	2.6	2.4	2.3	2.3								32
25	2.2	2.0	1.9	1.9	1.8	1.8	Nonusable range					41
20	1.8	1.6	1.5	1.5	1.5	1.4	1.4	1.4				54
15	1.3	1.2	1.2	1.1	1.1	1.1	1.1	1.0	1.0	1.0	0.9	82
10	0.9	0.8	0.8	0.8	0.7	0.7	0.7	0.7	0.7	0.6	0.6	↑
5	0.4	0.4	0.4	0.4	0.4	0.4	0.3	0.3	0.3	0.3	0.3	82

model CTK04		Clamping force $F = P / (6.88 + 0.0324 \times LH)$										
Hydraulic pressure MPa	Cylinder force kN	Clamping force kN										Max. arm length Max. LH mm
		Clamp arm length LH mm										
		25	30	40	50	60	70	80	90	100	120	
35	5.1	4.6	4.5	4.3								40
30	4.4	3.9	3.8	3.7								49
25	3.6	3.3	3.2	3.1	2.9	2.8	Nonusable range					62
20	2.9	2.6	2.5	2.4	2.4	2.3	2.2	2.1				84
15	2.2	2.0	1.9	1.8	1.8	1.7	1.6	1.6	1.5	1.5	1.4	131
10	1.5	1.3	1.3	1.2	1.2	1.1	1.1	1.1	1.0	1.0	0.9	↑
5	0.7	0.7	0.6	0.6	0.6	0.6	0.5	0.5	0.5	0.5	0.5	131

model CTK06		Clamping force $F = P / (4.61 + 0.0185 \times LH)$										
Hydraulic pressure MPa	Cylinder force kN	Clamping force kN										Max. arm length Max. LH mm
		Clamp arm length LH mm										
		30	40	50	60	70	80	100	120	140	160	
35	7.6	6.8	6.5	6.3								54
30	6.5	5.8	5.6	5.4	5.2							66
25	5.4	4.8	4.7	4.5	4.4	4.2	4.1	Nonusable range				84
20	4.3	3.9	3.7	3.6	3.5	3.4	3.3	3.1				116
15	3.3	2.9	2.8	2.7	2.6	2.5	2.5	2.3	2.2	2.1	2.0	185
10	2.2	1.9	1.9	1.8	1.7	1.7	1.6	1.5	1.5	1.4	1.3	↑
5	1.1	1.0	0.9	0.9	0.9	0.8	0.8	0.8	0.7	0.7	0.7	185

model CTK10		Clamping force $F = P / (2.40 + 0.00776 \times LH)$										
Hydraulic pressure MPa	Cylinder force kN	Clamping force kN										Max. arm length Max. LH mm
		Clamp arm length LH mm										
		35	40	50	60	70	80	100	120	140	160	
35	14.6	13.1	12.9	12.6								52
30	12.5	11.2	11.1	10.8	10.5							63
25	10.4	9.4	9.2	9.0	8.7	8.5	Nonusable range					79
20	8.3	7.5	7.4	7.2	7.0	6.8	6.6	6.3				107
15	6.3	5.6	5.5	5.4	5.2	5.1	5.0	4.7	4.5	4.3	4.1	164
10	4.2	3.7	3.7	3.6	3.5	3.4	3.3	3.1	3.0	2.9	2.7	↑
5	2.1	1.9	1.8	1.8	1.7	1.7	1.7	1.6	1.5	1.4	1.4	164

model CTK16		Clamping force $F = P / (1.72 + 0.00479 \times LH)$											
Hydraulic pressure MPa	Cylinder force kN	Clamping force kN										Max. arm length Max. LH mm	
		Clamp arm length LH mm											
		40	50	60	70	80	100	120	140	160	180		
35	20.3	18.3	17.9	17.4	17.0	16.6						83	
30	17.4	15.7	15.3	14.9	14.6	14.3	13.6	Nonusable range					101
25	14.5	13.1	12.8	12.5	12.2	11.9	11.4	10.9				131	
20	11.6	10.5	10.2	10.0	9.7	9.5	9.1	8.7	8.4	8.0	7.7	182	
15	8.7	7.8	7.7	7.5	7.3	7.1	6.8	6.5	6.3	6.0	5.8	297	
10	5.8	5.2	5.1	5.0	4.9	4.8	4.5	4.4	4.2	4.0	3.9	↑	
5	2.9	2.6	2.6	2.5	2.4	2.4	2.3	2.2	2.1	2.0	1.9	297	

● See the formula shown on page → 20 for clamping force calculation when pin rod type (CTK□□-□P) is selected.

Swing speed adjustment

Swing time is restricted by the mass and length of the clamp arm (moment of inertia) since the 90° swing action impacts the cam shaft.

1. Calculate the moment of inertia according to the arm length and mass.
 2. Adjust swing speed with flow control valve to ensure that 90° swing time of the clamp arm is greater than the shortest swing time in the graph shown below.
- The cam groove may be damaged in case the swing speed is set at the nonusable range in the graph.

Example of calculation for moment of inertia

$$I = \frac{1}{12} m_1 (4A_1^2 + B^2) + \frac{1}{12} m_2 (4A_2^2 + B^2)$$

I : Moment of inertia (kg·m²)

m : Mass (kg)

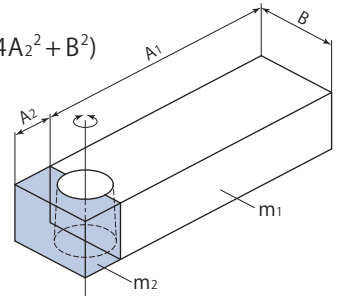

model CTK02

Shortest swing time calculation formula $t = \sqrt{\frac{I}{0.00965}}$

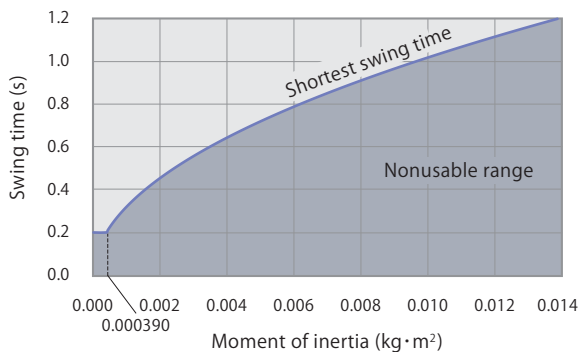

model CTK04

Shortest swing time calculation formula $t = \sqrt{\frac{I}{0.0265}}$

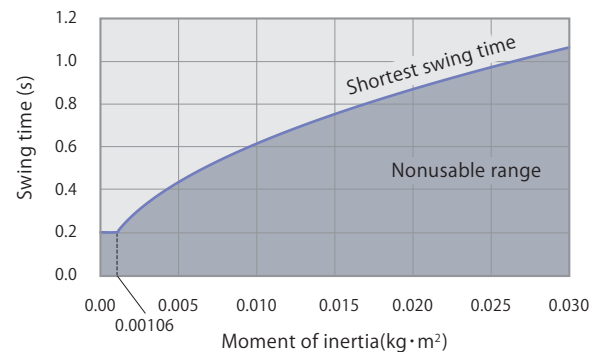

model CTK06

Shortest swing time calculation formula $t = \sqrt{\frac{I}{0.0590}}$

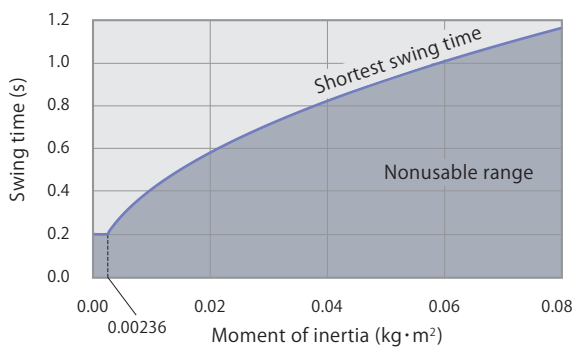

model CTK10

Shortest swing time calculation formula $t = \sqrt{\frac{I}{0.120}}$

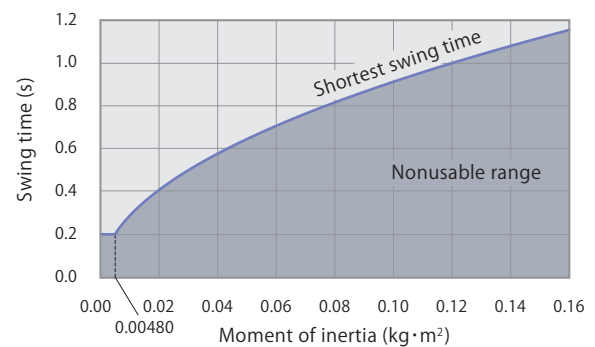

model CTK16

Shortest swing time calculation formula $t = \sqrt{\frac{I}{0.268}}$

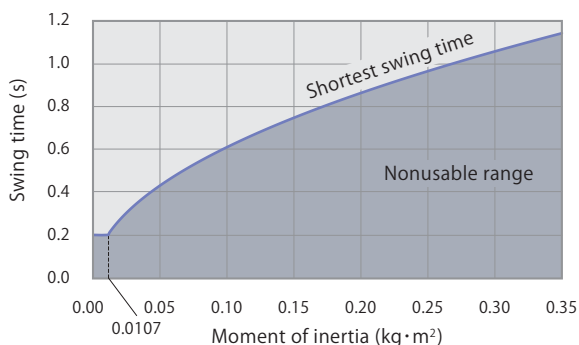

Dimensions

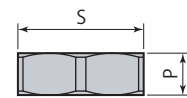
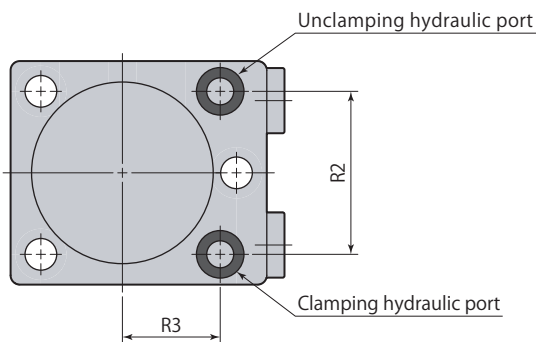
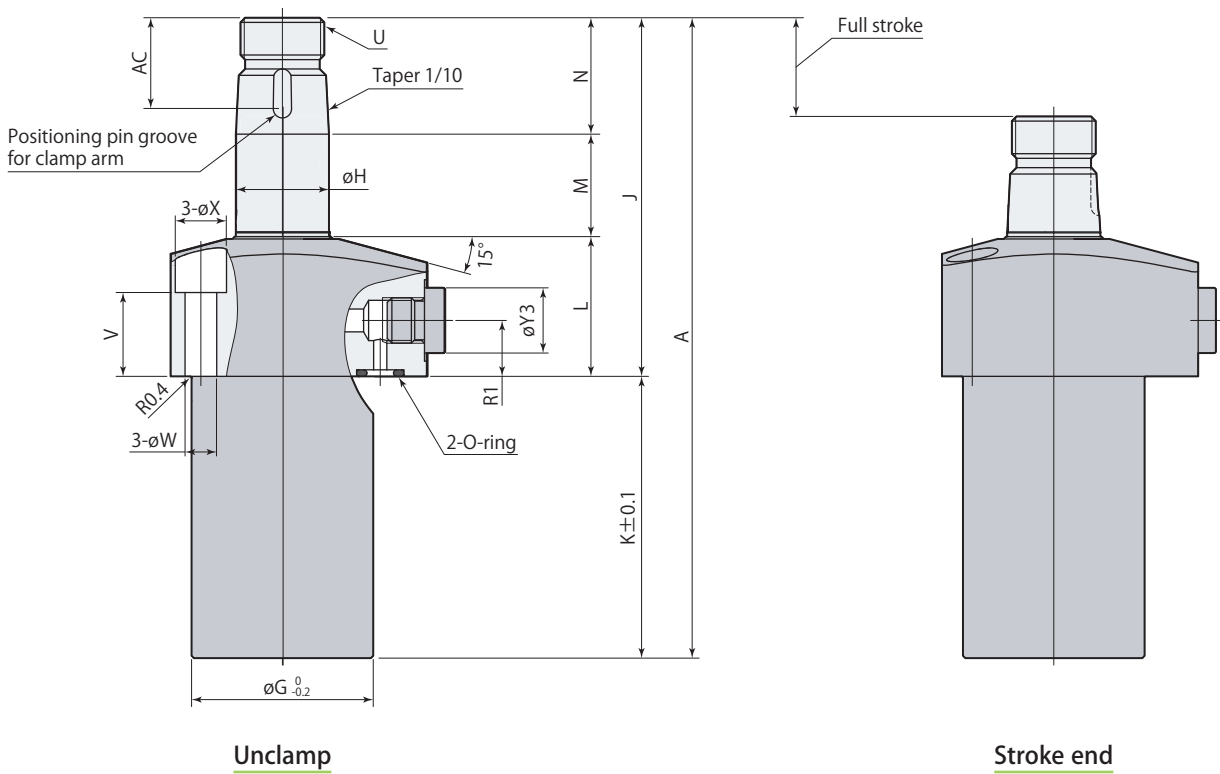
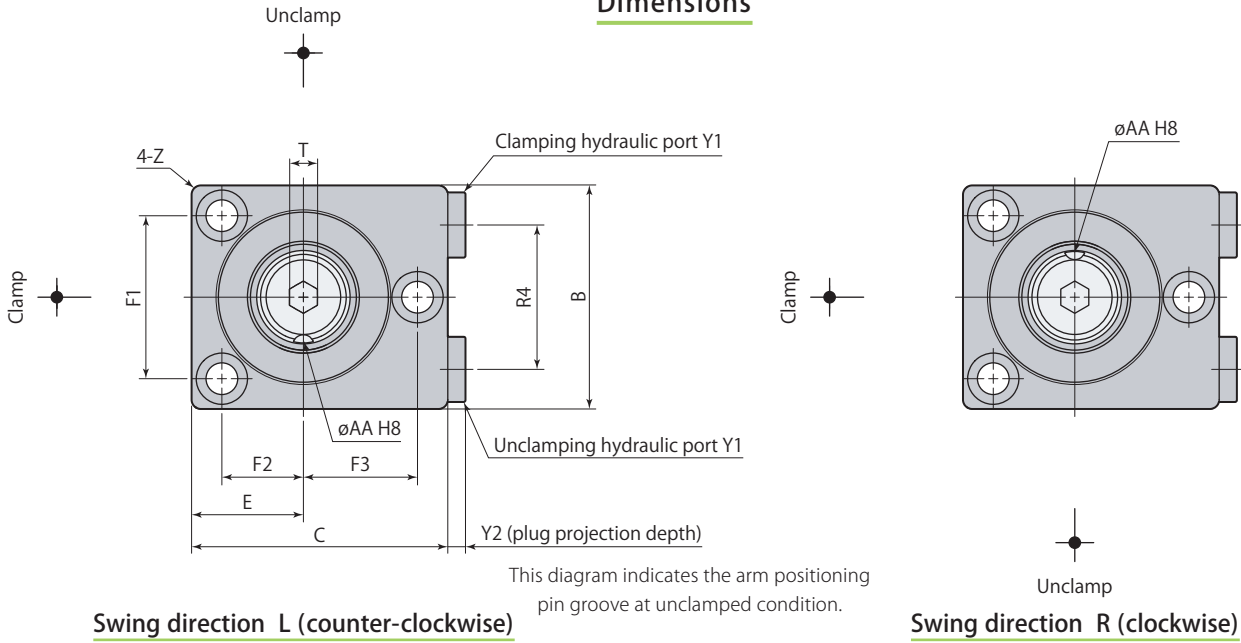

Hex nut for arm mount

- Hex nut for arm mount is included.
- Refer to **page → 39** for the details of perfect nut.
- Clamp arm, positioning pin and mounting screws are not included.

CTK□U-□	Swing clamp Upper flange	35MPa	Double acting
----------------	---------------------------------	--------------	----------------------

Model	CTK02U-□	CTK04U-□	CTK06U-□	CTK10U-□	CTK16U-□
A	103	118	137.5	165	191.5
B	37	43	48	60	74
C	42	50	55	70	85
E	18.5	21.5	24	30	37
F1	26	32	35	44	54
F2	13	16	17.5	22	27
F3	18	22.5	24.5	32	38
øG	27	33	39	48	58
øH	12	16	20	25	32
J	55.5	64	77	89.5	103
K	47.5	54	60.5	75.5	88.5
L	21	24	30	34	37.5
M	16	18	22	26.5	29.5
N	18.5	22	25	29	36
P	6.5	8	9	10	11
R1	–	9.5	12	12.5	14
R2	22	30	35	44	56
R3	17	18.5	21	30	33
R4	–	26	31	40	50
S (nut width across flats)	17	22	27	30	36
T (hex socket)	4	5	6	10	12
U	M10×0.75	M14×1.5	M18×1.5	M22×1.5	M28×1.5
V	11	12	18	18	18
øW	5.5	5.5	6.8	9	11
øX	9.5	9.5	11	14	17.5
Y1*1	–	G1/8	G1/8	G1/8	G1/4
Y2	–	3.8	3.8	3.8	4.8
øY3	–	14	14	14	19
Z	R2	R2	R2	R3	R3
øAA (pin groove diameter)	2.5 ^{+0.014} ₀	3 ^{+0.014} ₀	4 ^{+0.018} ₀	5 ^{+0.018} ₀	6 ^{+0.018} ₀
AC	13	16.5	19.5	22.5	23.5
Positioning pin (dowel pin)	ø2.5(h8)×6	ø3(h8)×8	ø4(h8)×10	ø5(h8)×12	ø6(h8)×12
O-ring (fluorocarbon hardness Hs90)	P5	P7	P7	P7	P8
Taper sleeve	CTH02-KS	CTH04-KS	CTH06-KS	CTH10-KS	CTH16-KS
Flow control valve (meter-in)*2	–	VCH01	VCH01	VCH01	VCH02
Air bleeding valve*2	–	VCE01	VCE01	VCE01	VCE02

*1: There is no piping port on model CTK02 (Manifold piping connection only).

*2: Select the right model of VCH and VCE according to the size of the clamp.

Refer to each page for the details of options.

● Taper sleeve **page → 38** ● Flow control valve **page → 44** ● Air bleeding valve **page → 46**

● CTK□U-C (straight, swing angle 0°) is made to order.

Mounting details

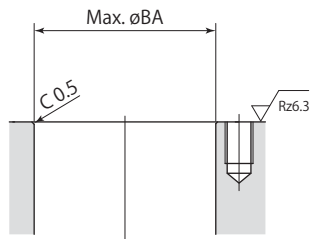
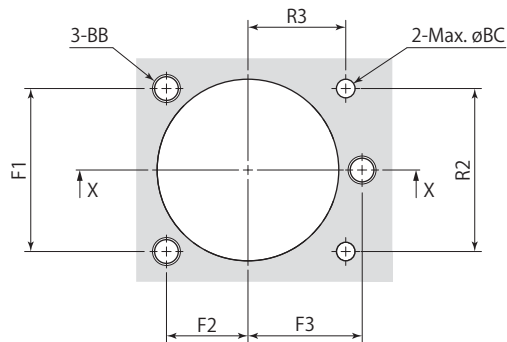

X-X

Rz: ISO4287(1997)

Model	CTK02U-□	CTK04U-□	CTK06U-□	CTK10U-□	CTK16U-□
F1	26	32	35	44	54
F2	13	16	17.5	22	27
F3	18	22.5	24.5	32	38
R2	22	30	35	44	56
R3	17	18.5	21	30	33
øBA	28	34	40	49	59
BB	M5	M5	M6	M8	M10
øBC	3	5	5	5	6

mm

Dimensions

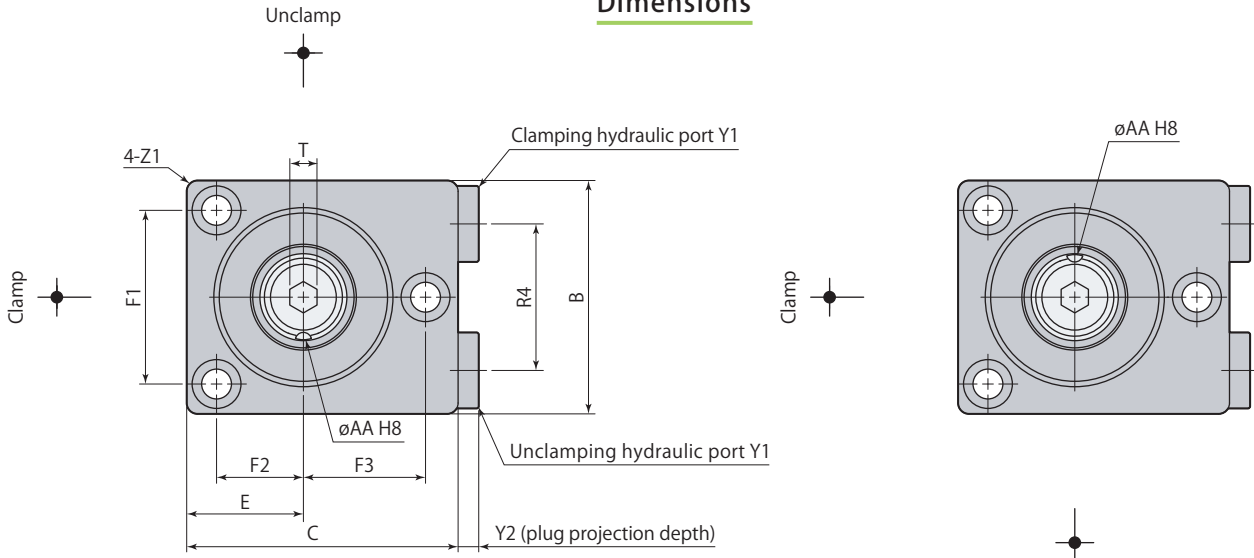

This diagram indicates the arm positioning pin groove at unclamped condition.

Swing direction L (counter-clockwise)

Swing direction R (clockwise)

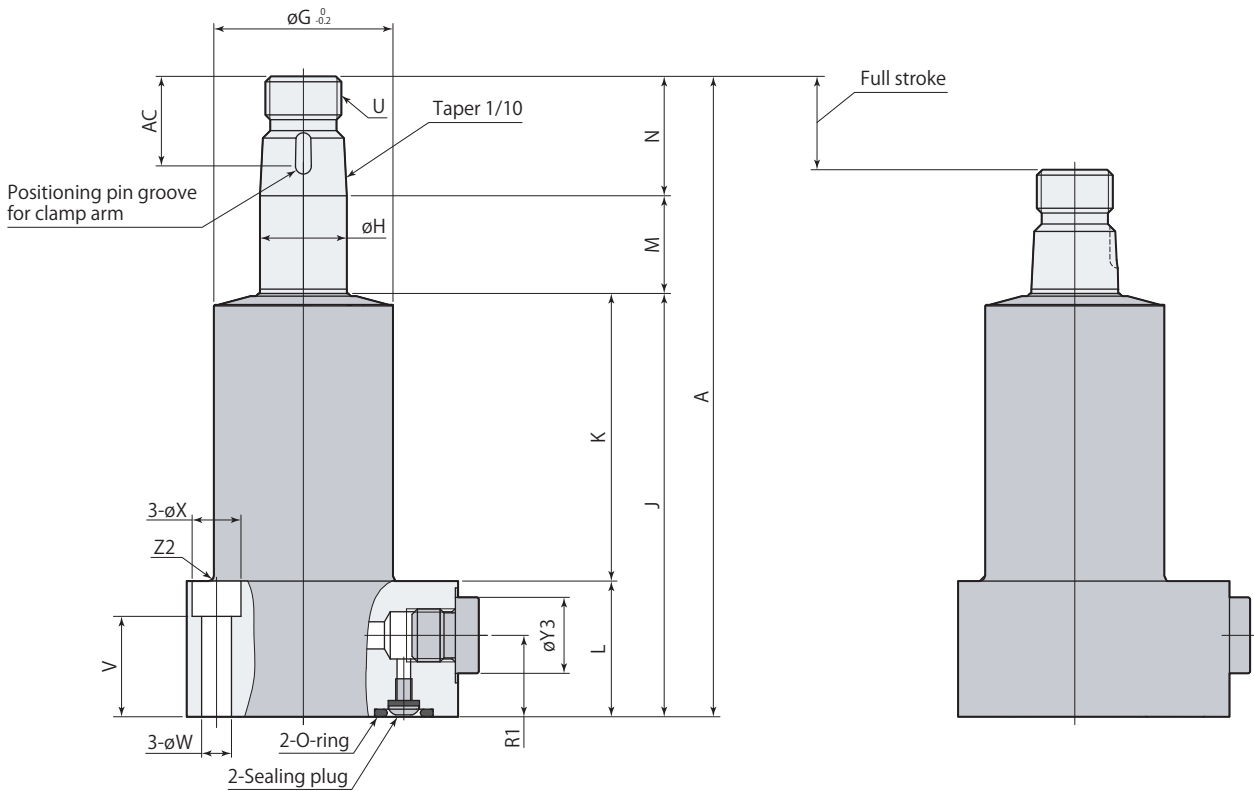

Unclamp

Stroke end

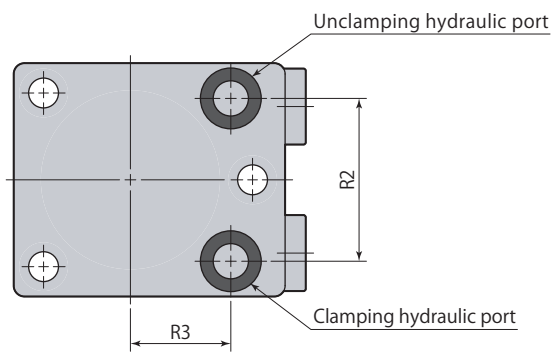

- Hex nut for arm mount is included.
- Refer to **page → 39** for the details of perfect nut.
- Clamp arm, positioning pin and mounting screws are not included.

CTK□B-□	Swing clamp Lower flange	35MPa	Double acting
----------------	---------------------------------	--------------	----------------------

Model	CTK02B-□	CTK04B-□	CTK06B-□	CTK10B-□	CTK16B-□
A	103	118	137.5	165	191.5
B	38	43	52	63	77
C	43	50	57	70	86.5
E	18.5	21.5	24	30	37
F1	27	32	39	47	57
F2	13	16	17.5	22	27
F3	19	22.5	26.5	32	39.5
øG	27.5	33	40.5	49	60
øH	12	16	20	25	32
J	68.5	78	90.5	109.5	126
K	50.5	53	64	82.5	93
L	18	25	26.5	27	33
M	16	18	22	26.5	29.5
N	18.5	22	25	29	36
P	6.5	8	9	10	11
R1	–	15	16.5	17	22
R2	22	30	35	44	56
R3	18	18.5	23	30	34.5
R4	–	27	32	40	50
S (nut width across flats)	17	22	27	30	36
T (hex socket)	4	5	6	10	12
U	M10×0.75	M14×1.5	M18×1.5	M22×1.5	M28×1.5
V	12	18.5	18.5	16	20
øW	5.5	5.5	6.8	9	11
øX	9	9	11	14	17.5
Y1*1	–	G1/8	G1/8	G1/8	G1/4
Y2	–	3.8	3.8	3.8	4.8
øY3	–	14	14	14	19
Z1	R2	R2	R2	R3	R3
Z2	R1	R1	R1	R1	R2
øAA (pin groove diameter)	2.5 ^{+0.014} ₀	3 ^{+0.014} ₀	4 ^{+0.018} ₀	5 ^{+0.018} ₀	6 ^{+0.018} ₀
AC	13	16.5	19.5	22.5	23.5
Positioning pin (dowel pin)	ø2.5(h8)×6	ø3(h8)×8	ø4(h8)×10	ø5(h8)×12	ø6(h8)×12
O-ring (fluorocarbon hardness Hs90)	P5	P8	P9	P9	P9
Taper sleeve	CTH02-KS	CTH04-KS	CTH06-KS	CTH10-KS	CTH16-KS
Flow control valve (meter-in)*2	–	VCH01	VCH01	VCH01	VCH02
Air bleeding valve*2	–	VCE01	VCE01	VCE01	VCE02

*1: There is no piping port on model CTK02 (Manifold piping connection only).

*2: Select the right model of VCH and VCE according to the size of the clamp.

Refer to each page for the details of options.

● Taper sleeve **page → 38** ● Flow control valve **page → 44** ● Air bleeding valve **page → 46**

● CTK□B-C (straight, swing angle 0°) is made to order.

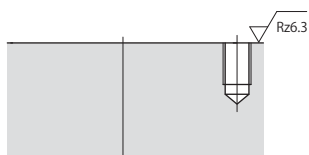
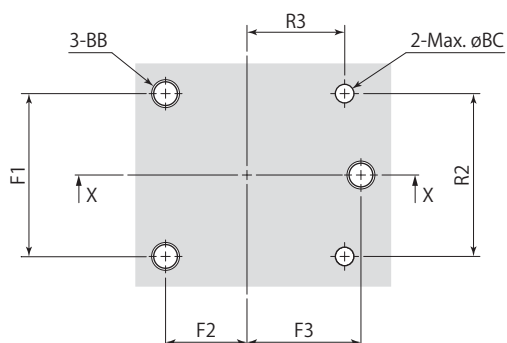
Mounting details

X-X

Rz: ISO4287(1997)

Model	CTK02B-□	CTK04B-□	CTK06B-□	CTK10B-□	CTK16B-□
F1	27	32	39	47	57
F2	13	16	17.5	22	27
F3	19	22.5	26.5	32	39.5
R2	22	30	35	44	56
R3	18	18.5	23	30	34.5
BB	M5	M5	M6	M8	M10
øBC	3	6	7	7	7

mm

Dimensions

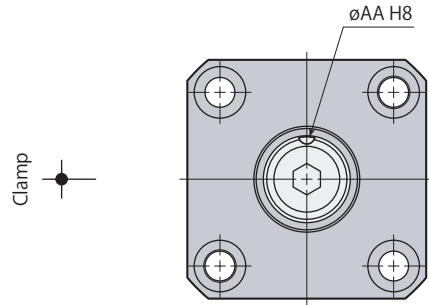
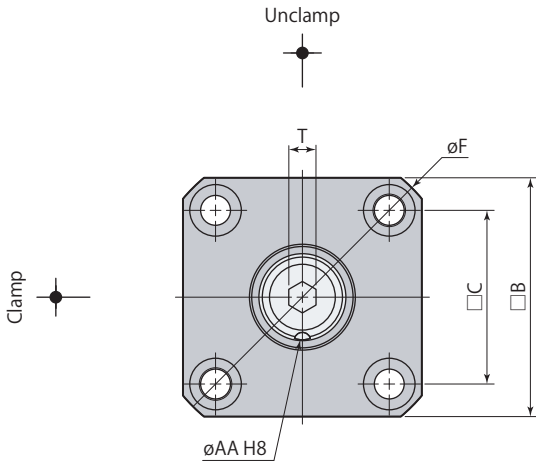

This diagram indicates the arm positioning pin groove at unclamped condition.

Swing direction L (counter-clockwise)

Swing direction R (clockwise)

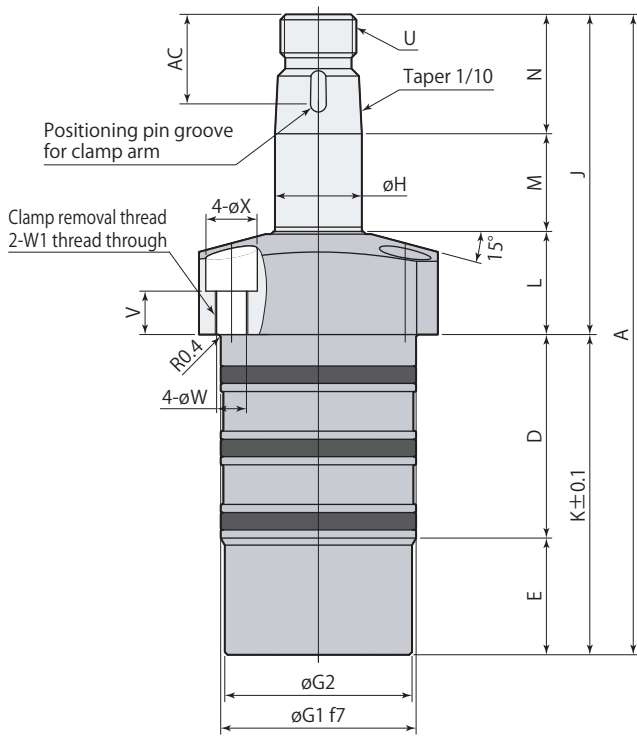

Unclamp

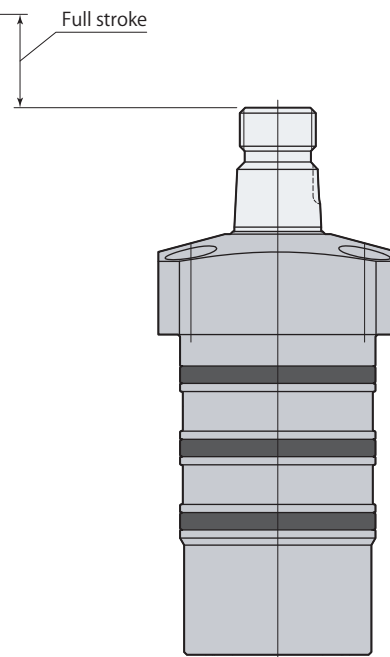

Stroke end

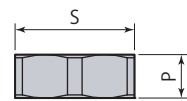
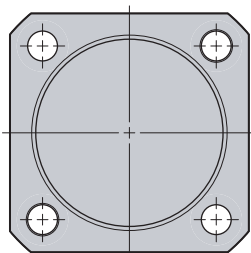

Hex nut for arm mount

- Hex nut for arm mount is included.
- Refer to **page → 39** for the details of perfect nut.
- Clamp arm, positioning pin and mounting screws are not included.

Model	CTK02N-□	CTK04N-□	CTK06N-□	CTK10N-□	CTK16N-□
A	103	118	137.5	165	191.5
B	39	44	50	62	75
C	28	32	37	46	55
D	34.5	37.5	39.5	49.5	54.5
E	17	21.5	27	33	42.5
øF	51	57	66	82	98
øG1	30 ^{-0.020 -0.041}	36 ^{-0.025 -0.050}	42 ^{-0.025 -0.050}	51 ^{-0.030 -0.060}	61 ^{-0.030 -0.060}
øG2	29	34.5	40.5	49.5	59.5
H	12	16	20	25	32
J	51.5	59	71	82.5	94.5
K	51.5	59	66.5	82.5	97
L	17	19	24	27	29
M	16	18	22	26.5	29.5
N	18.5	22	25	29	36
P	6.5	8	9	10	11
S (nut width across flats)	17	22	27	30	36
T (hex socket)	4	5	6	10	12
U	M10×0.75	M14×1.5	M18×1.5	M22×1.5	M28×1.5
V	6	8	11.5	10	9.5
øW	5.5	5.5	6.8	9	11
W1	M6×1.0	M6×1.0	M8×1.25	M10×1.5	M12×1.75
øX	9.5	9.5	11	14	17.5
øAA (pin groove diameter)	2.5 ^{+0.014 0}	3 ^{+0.014 0}	4 ^{+0.018 0}	5 ^{+0.018 0}	6 ^{+0.018 0}
AC	13	16.5	19.5	22.5	23.5
Positioning pin (dowel pin)	ø2.5(h8)×6	ø3(h8)×8	ø4(h8)×10	ø5(h8)×12	ø6(h8)×12
Taper sleeve	CTH02-KS	CTH04-KS	CTH06-KS	CTH10-KS	CTH16-KS

- Refer to **page → 38** for the details of taper sleeve.
- When removing clamp from mounting hole, use removal tap hole. (Refer to **page → 42** for caution in use.)
- CTK□N-□ (Cartridge) is made to order.

Mounting details

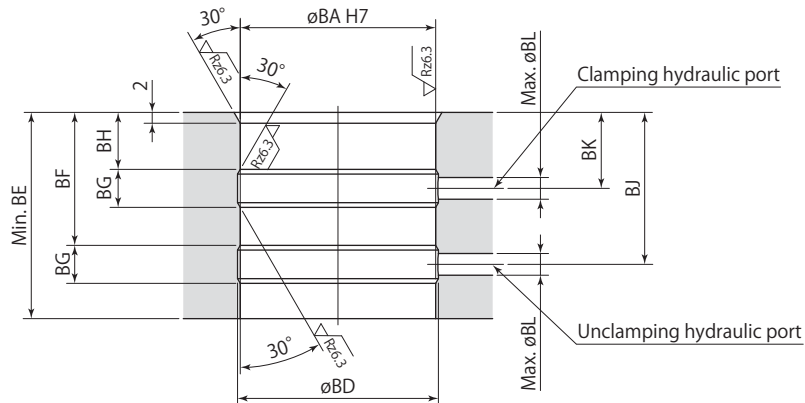
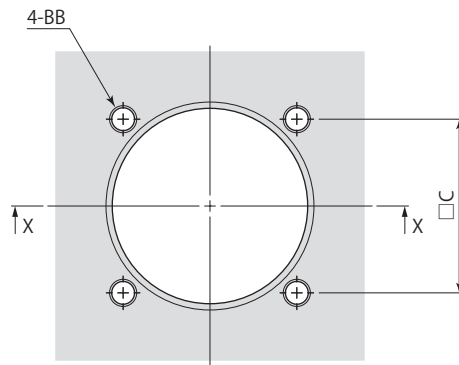

X-X

Rz: ISO4287(1997)

mm

Model	CTK02N-□	CTK04N-□	CTK06N-□	CTK10N-□	CTK16N-□
C	28	32	37	46	55
ϕBA	$30^{+0.021}_0$	$36^{+0.025}_0$	$42^{+0.025}_0$	$51^{+0.030}_0$	$61^{+0.030}_0$
BB	M5	M5	M6	M8	M10
ϕBD	31	37	43	52	62
BE	35	38	40	50	55
BF	22.5	24.5	26.5	33.5	38.5
BG	6	7	7	10	10
BH	10	10.5	13	16.5	21.5
BJ	25.5 ± 0.5	28 ± 0.5	30 ± 0.5	38.5 ± 1	43.5 ± 1
BK	13 ± 0.5	14 ± 0.5	16.5 ± 0.5	21.5 ± 1	26.5 ± 1
ϕBL	3	4	4	6	6

Specifications

	Size	Mounting and piping types	Swing direction (when clamping)	
CTK	02	U : Upper flange	L : Counter-clockwise	P : Pin rod
	04			
	06	B : Lower flange	R : Clockwise	
	10	N : Cartridge		
	16			

■ indicates made to order.

Usage example

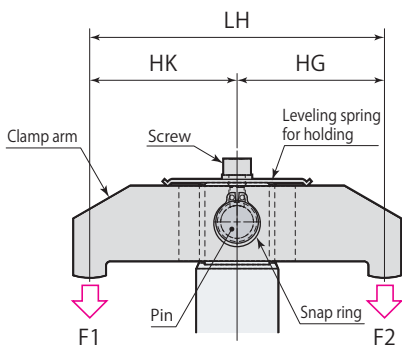

Clamping performance

Clamping force calculation formula

$$F1 = \frac{HG}{LH} \times n \times P$$

$$F2 = \frac{HK}{LH} \times n \times P$$

F1, F2=Clamping force (kN),
 n=Coefficient (refer to right table),
 P=Hydraulic pressure (MPa),
 HG, HK=Distance from center of piston to clamping point (mm), LH=(mm)

Model	Coefficient n
CTK02□-□P	0.088
CTK04□-□P	0.145
CTK06□-□P	0.217
CTK10□-□P	0.417
CTK16□-□P	0.581

- Clamp arm, pin and snap ring are not included. Customers must arrange for them.
- Thread at top portion of the rod is for attaching a leveling spring. Screw and leveling spring are not included.

Upper flange, pin rod

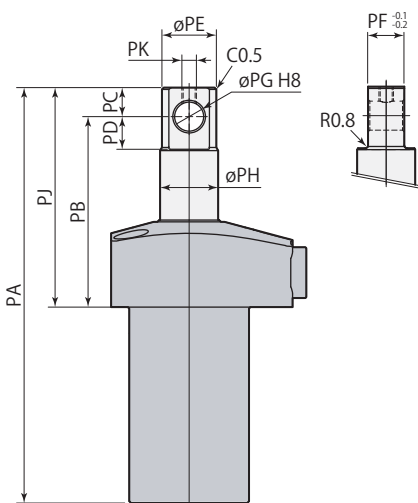

Model	CTK02U-□P	CTK04U-□P	CTK06U-□P	CTK10U-□P	CTK16U-□P
PA	99	114.5	135	166.5	190
PB	45.5	52.5	64.5	77	85.5
PC	6	8	10	14	16
PD	7	9	11	15	17
PE	11	15	19	24	30
PF	7.5	10	12	18	20
PG	6 ^{+0.018} ₀	8 ^{+0.022} ₀	10 ^{+0.022} ₀	14 ^{+0.027} ₀	16 ^{+0.027} ₀
PH	12	16	20	25	32
PJ	51.5	60.5	74.5	91	101.5
PK	M3×0.5	M4×0.7	M5×0.8	M6×1.0	M8×1.25
Mass	0.4 kg	0.7 kg	1.1 kg	1.9 kg	3.3 kg

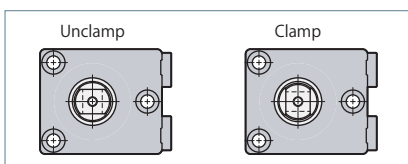

- This diagram indicates unclamped condition. Direction of pin hole will be hydraulic port side at the time of clamping.
- Refer to specifications (page → 4), dimensions (page → 8) for specifications and dimensions of products that are not listed on this diagram.

Lower flange, pin rod

mm

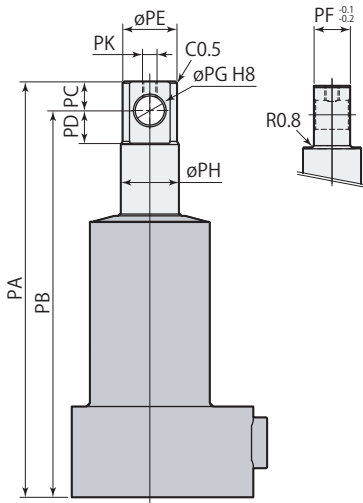

Model	CTK02B-□P	CTK04B-□P	CTK06B-□P	CTK10B-□P	CTK16B-□P
PA	99	114.5	135	166.5	190
PB	93	106.5	125	152.5	174
PC	6	8	10	14	16
PD	7	9	11	15	17
PE	11	15	19	24	30
PF	7.5	10	12	18	20
PG	6 ^{+0.018} ₀	8 ^{+0.022} ₀	10 ^{+0.022} ₀	14 ^{+0.027} ₀	16 ^{+0.027} ₀
PH	12	16	20	25	32
PK	M3×0.5	M4×0.7	M5×0.8	M6×1.0	M8×1.25
Mass	0.4 kg	0.7 kg	1.1 kg	1.9 kg	3.3 kg

- This diagram indicates unclamped condition. Direction of pin hole will be hydraulic port side at the time of clamping.
- Refer to specifications (page → 4), dimensions (page → 12) for specifications and dimensions of products that are not listed on this diagram.

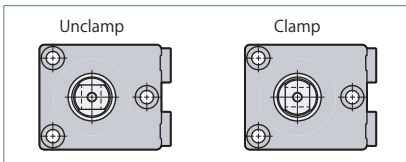

Cartridge, pin rod

mm

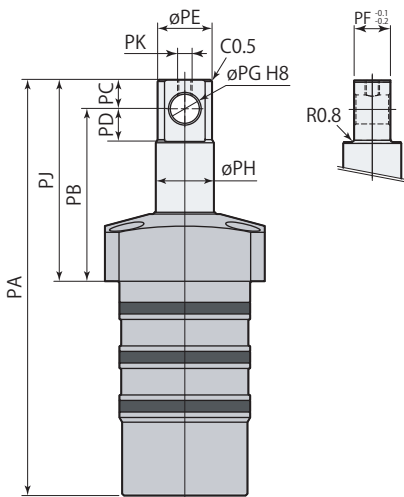

Model	CTK02N-□P	CTK04N-□P	CTK06N-□P	CTK10N-□P	CTK16N-□P
PA	99	114.5	135	166.5	190
PB	41.5	47.5	58.5	70	77
PC	6	8	10	14	16
PD	7	9	11	15	17
PE	11	15	19	24	30
PF	7.5	10	12	18	20
PG	6 ^{+0.018} ₀	8 ^{+0.022} ₀	10 ^{+0.022} ₀	14 ^{+0.027} ₀	16 ^{+0.027} ₀
PH	12	16	20	25	32
PJ	47.5	55.5	68.5	84	93
PK	M3×0.5	M4×0.7	M5×0.8	M6×1.0	M8×1.25
Mass	0.4 kg	0.7 kg	1.1 kg	1.9 kg	3.3 kg

- Refer to specifications (page → 4), dimensions (page → 16) for specifications and dimensions of products that are not listed on this diagram.

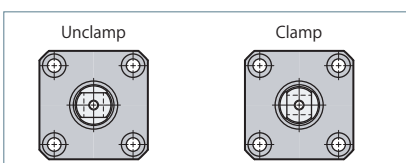

Specifications

Size	Mounting and piping types	Swing direction (when clamping), swing angle
02	U : Upper flange	L30 : Counter-clockwise, swing angle 30°
04		L45 : Counter-clockwise, swing angle 45°
06		L60 : Counter-clockwise, swing angle 60°
10		R30 : Clockwise, swing angle 30°
16		R45 : Clockwise, swing angle 45° R60 : Clockwise, swing angle 60°

■ indicates made to order.

Upper flange, swing angle 30°, 45°, 60°

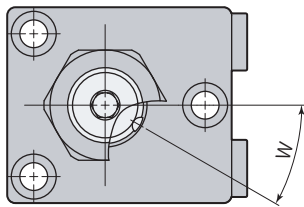

mm						
Model	CTK02U-□30	CTK04U-□30	CTK06U-□30	CTK10U-□30	CTK16U-□30	
W (swing angle)	30°±5°					
Full stroke	11.5	12.5	15.5	18.8	20.3	
Swing stroke	3.5	4.5	5.5	6.8	8.3	
Clamp stroke	8	8	10	12	12	
Cylinder capacity	Clamp	1.0 cm ³	1.8 cm ³	3.4 cm ³	7.8 cm ³	11.8 cm ³
	Unclamp	2.3 cm ³	4.3 cm ³	8.2 cm ³	17.0 cm ³	28.1 cm ³
A	99.5	113.5	132	158.3	183.3	
J	52	59.5	71.5	82.8	94.8	
M	12.5	13.5	16.5	19.8	21.3	

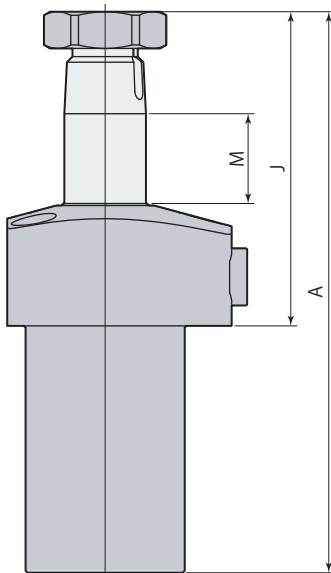

mm						
Model	CTK02U-□45	CTK04U-□45	CTK06U-□45	CTK10U-□45	CTK16U-□45	
W (swing angle)	45°±5°					
Full stroke	12.4	13.6	16.9	20.4	22.3	
Swing stroke	4.4	5.6	6.9	8.4	10.3	
Clamp stroke	8	8	10	12	12	
Cylinder capacity	Clamp	1.1 cm ³	2.0 cm ³	3.7 cm ³	8.5 cm ³	13.0 cm ³
	Unclamp	2.5 cm ³	4.7 cm ³	9.0 cm ³	18.6 cm ³	30.9 cm ³
A	100.4	114.6	133.4	159.9	185.3	
J	52.9	60.6	72.9	84.4	96.8	
M	13.4	14.6	17.9	21.4	23.3	

mm						
Model	CTK02U-□60	CTK04U-□60	CTK06U-□60	CTK10U-□60	CTK16U-□60	
W (swing angle)	60°±5°					
Full stroke	13.3	14.8	18.3	22.1	24.4	
Swing stroke	5.3	6.8	8.3	10.1	12.4	
Clamp stroke	8	8	10	12	12	
Cylinder capacity	Clamp	1.2 cm ³	2.1 cm ³	4.0 cm ³	9.2 cm ³	14.2 cm ³
	Unclamp	2.7 cm ³	5.1 cm ³	9.7 cm ³	20.1 cm ³	33.8 cm ³
A	101.3	115.8	134.8	161.6	187.4	
J	53.8	61.8	74.3	86.1	98.9	
M	14.3	15.8	19.3	23.1	25.4	

- This diagram indicates unclamped condition.
- Refer to specifications (page → 4), dimensions (page → 8) for specifications and dimensions of products that are not listed on this diagram.

Specifications

Size	Mounting and piping types	Swing direction (when clamping), swing angle
02	B : Lower flange —	L30 : Counter-clockwise, swing angle 30°
04		L45 : Counter-clockwise, swing angle 45°
06		L60 : Counter-clockwise, swing angle 60°
10		R30 : Clockwise, swing angle 30°
16		R45 : Clockwise, swing angle 45° R60 : Clockwise, swing angle 60°

■ indicates made to order.

Lower flange, swing angle 30°, 45°, 60°

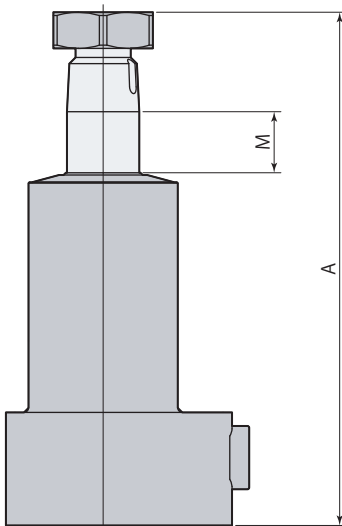
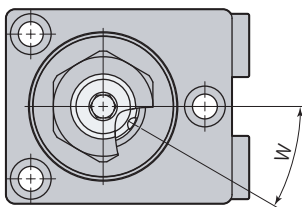

Model		CTK02B-□30	CTK04B-□30	CTK06B-□30	CTK10B-□30	CTK16B-□30
W (swing angle)		30°±5°				
Full stroke		11.5	12.5	15.5	18.8	20.3
Swing stroke		3.5	4.5	5.5	6.8	8.3
Clamp stroke		8	8	10	12	12
Cylinder capacity	Clamp	1.0 cm ³	1.8 cm ³	3.4 cm ³	7.8 cm ³	11.8 cm ³
	Unclamp	2.3 cm ³	4.3 cm ³	8.2 cm ³	17.0 cm ³	28.1 cm ³
A		99.5	113.5	132	158.3	183.3
M		12.5	13.5	16.5	19.8	21.3

Model		CTK02B-□45	CTK04B-□45	CTK06B-□45	CTK10B-□45	CTK16B-□45
W (swing angle)		45°±5°				
Full stroke		12.4	13.6	16.9	20.4	22.3
Swing stroke		4.4	5.6	6.9	8.4	10.3
Clamp stroke		8	8	10	12	12
Cylinder capacity	Clamp	1.1 cm ³	2.0 cm ³	3.7 cm ³	8.5 cm ³	13.0 cm ³
	Unclamp	2.5 cm ³	4.7 cm ³	9.0 cm ³	18.6 cm ³	30.9 cm ³
A		100.4	114.6	133.4	159.9	185.3
M		13.4	14.6	17.9	21.4	23.3

Model		CTK02B-□60	CTK04B-□60	CTK06B-□60	CTK10B-□60	CTK16B-□60
W (swing angle)		60°±5°				
Full stroke		13.3	14.8	18.3	22.1	24.4
Swing stroke		5.3	6.8	8.3	10.1	12.4
Clamp stroke		8	8	10	12	12
Cylinder capacity	Clamp	1.2 cm ³	2.1 cm ³	4.0 cm ³	9.2 cm ³	14.2 cm ³
	Unclamp	2.7 cm ³	5.1 cm ³	9.7 cm ³	20.1 cm ³	33.8 cm ³
A		101.3	115.8	134.8	161.6	187.4
M		14.3	15.8	19.3	23.1	25.4

- This diagram indicates unclamped condition.
- Refer to specifications (page → 4), dimensions (page → 12) for specifications and dimensions of products that are not listed on this diagram.

Specifications

Size	Mounting and piping types	Swing direction (when clamping), swing angle
02	N : Cartridge	L30 : Counter-clockwise, swing angle 30°
04		L45 : Counter-clockwise, swing angle 45°
06		L60 : Counter-clockwise, swing angle 60°
10		R30 : Clockwise, swing angle 30°
16		R45 : Clockwise, swing angle 45° R60 : Clockwise, swing angle 60°

■ indicates made to order.

Cartridge, swing angle 30°, 45°, 60°

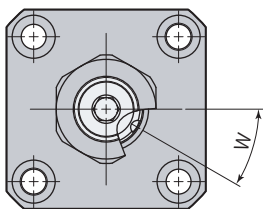

Model		CTK02N-□30	CTK04N-□30	CTK06N-□30	CTK10N-□30	CTK16N-□30
W (swing angle)		30°±5°				
Full stroke		11.5	12.5	15.5	18.8	20.3
Swing stroke		3.5	4.5	5.5	6.8	8.3
Clamp stroke		8	8	10	12	12
Cylinder capacity	Clamp	1.0 cm ³	1.8 cm ³	3.4 cm ³	7.8 cm ³	11.8 cm ³
	Unclamp	2.3 cm ³	4.3 cm ³	8.2 cm ³	17.0 cm ³	28.1 cm ³
A		99.5	113.5	132	158.3	183.3
J		48	54.5	65.5	75.8	86.3
M		12.5	13.5	16.5	19.8	21.3

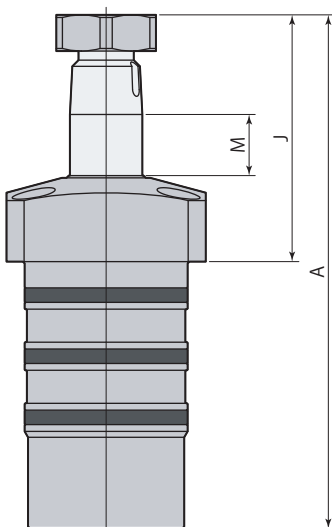

Model		CTK02N-□45	CTK04N-□45	CTK06N-□45	CTK10N-□45	CTK16N-□45
W (swing angle)		45°±5°				
Full stroke		12.4	13.6	16.9	20.4	22.3
Swing stroke		4.4	5.6	6.9	8.4	10.3
Clamp stroke		8	8	10	12	12
Cylinder capacity	Clamp	1.1 cm ³	2.0 cm ³	3.7 cm ³	8.5 cm ³	13.0 cm ³
	Unclamp	2.5 cm ³	4.7 cm ³	9.0 cm ³	18.6 cm ³	30.9 cm ³
A		100.4	114.6	133.4	159.9	185.3
J		48.9	55.6	66.9	77.4	88.3
M		13.4	14.6	17.9	21.4	23.3

Model		CTK02N-□60	CTK04N-□60	CTK06N-□60	CTK10N-□60	CTK16N-□60
W (swing angle)		60°±5°				
Full stroke		13.3	14.8	18.3	22.1	24.4
Swing stroke		5.3	6.8	8.3	10.1	12.4
Clamp stroke		8	8	10	12	12
Cylinder capacity	Clamp	1.2 cm ³	2.1 cm ³	4.0 cm ³	9.2 cm ³	14.2 cm ³
	Unclamp	2.7 cm ³	5.1 cm ³	9.7 cm ³	20.1 cm ³	33.8 cm ³
A		101.3	115.8	134.8	161.6	187.4
J		49.8	56.8	68.3	79.1	90.4
M		14.3	15.8	19.3	23.1	25.4

- This diagram indicates unclamped condition.
- Refer to specifications (page → 4), dimensions (page → 16) for specifications and dimensions of products that are not listed on this diagram.

Specifications

Size Mounting and piping types Swing direction (when clamping), clamp stroke

CTK	02	U : Upper flange	—	LJ : Counter-clockwise, long stroke
	04			RJ : Clockwise, long stroke
	06			CJ : Straight, long stroke
	10			
	16			

■ indicates made to order.

Upper flange, long stroke

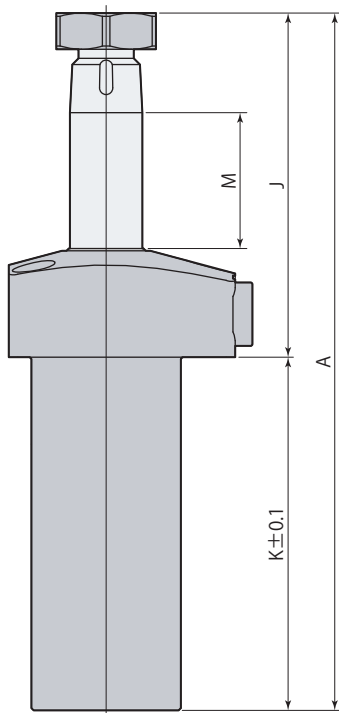
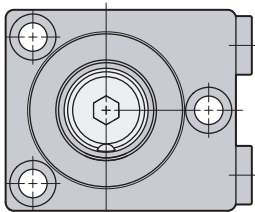

Model		CTK02U-□J	CTK04U-□J	CTK06U-□J	CTK10U-□J	CTK16U-□J
Swing angle	CTK□U-LJ, RJ	90°±3°				
	CTK□U-CJ	0°				
Full stroke		27	29	36	43.5	46.5
Swing stroke (CTK□U-LJ, RJ)		7	9	11	13.5	16.5
Clamp stroke (CTK□U-LJ, RJ)		20	20	25	30	30
Cylinder capacity	Clamp	2.4 cm ³	4.2 cm ³	7.8 cm ³	18.1 cm ³	27.0 cm ³
	Unclamp	5.4 cm ³	10.0 cm ³	19.1 cm ³	39.5 cm ³	64.4 cm ³
A		139	154	182.5	219	245.5
J		67.5	76	92	107.5	121
K		71.5	78	90.5	111.5	124.5
M		28	30	37	44.5	47.5
Mass		0.5 kg	0.9 kg	1.4 kg	2.4 kg	4.1 kg

- This diagram indicates unclamped condition.
- Refer to specifications (page → 4), dimensions (page → 8) for specifications and dimensions of products that are not listed on this diagram.

Specifications

Size	Mounting and piping types	Swing direction (when clamping), clamp stroke, swing angle
<p>CTK</p> <ul style="list-style-type: none"> 02 04 06 10 16 	<p>U : Upper flange</p>	<ul style="list-style-type: none"> LJ30 : Counter-clockwise, long stroke, swing angle 30° LJ45 : Counter-clockwise, long stroke, swing angle 45° LJ60 : Counter-clockwise, long stroke, swing angle 60° RJ30 : Clockwise, long stroke, swing angle 30° RJ45 : Clockwise, long stroke, swing angle 45° RJ60 : Clockwise, long stroke, swing angle 60° <p>■ indicates made to order.</p>

Upper flange, long stroke, swing angle 30°, 45°, 60°

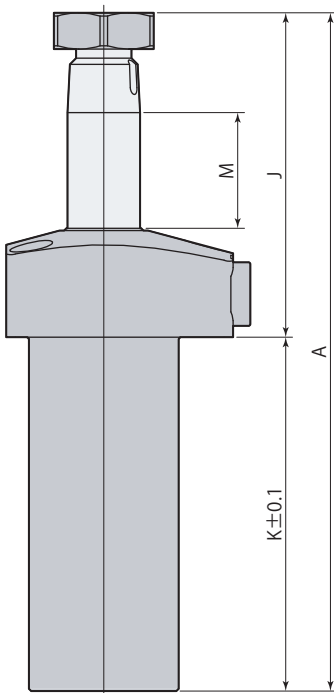
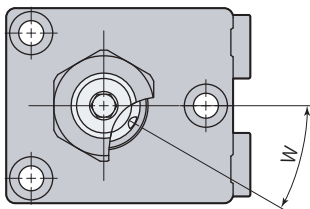

Model		CTK02U-□J30	CTK04U-□J30	CTK06U-□J30	CTK10U-□J30	CTK16U-□J30
W (swing angle)		30°±5°				
Full stroke		23.5	24.5	30.5	36.8	38.3
Swing stroke		3.5	4.5	5.5	6.8	8.3
Clamp stroke		20	20	25	30	30
Cylinder capacity	Clamp	2.1 cm ³	3.6 cm ³	6.6 cm ³	15.3 cm ³	22.3 cm ³
	Unclamp	4.7 cm ³	8.5 cm ³	16.2 cm ³	33.4 cm ³	53.1 cm ³
A		135.5	149.5	177	212.3	237.3
J		64	71.5	86.5	100.8	112.8
K		71.5	78	90.5	111.5	124.5
M		24.5	25.5	31.5	37.8	39.3

Model		CTK02U-□J45	CTK04U-□J45	CTK06U-□J45	CTK10U-□J45	CTK16U-□J45
W (swing angle)		45°±5°				
Full stroke		24.4	25.6	31.9	38.4	40.3
Swing stroke		4.4	5.6	6.9	8.4	10.3
Clamp stroke		20	20	25	30	30
Cylinder capacity	Clamp	2.1 cm ³	3.7 cm ³	6.9 cm ³	16.0 cm ³	23.4 cm ³
	Unclamp	4.9 cm ³	8.9 cm ³	16.9 cm ³	34.9 cm ³	55.8 cm ³
A		136.4	150.6	178.4	213.9	239.3
J		64.9	72.6	87.9	102.4	114.8
K		71.5	78	90.5	111.5	124.5
M		25.4	26.6	32.9	39.4	41.3

Model		CTK02U-□J60	CTK04U-□J60	CTK06U-□J60	CTK10U-□J60	CTK16U-□J60
W (swing angle)		60°±5°				
Full stroke		25.3	26.8	33.3	40.1	42.4
Swing stroke		5.3	6.8	8.3	10.1	12.4
Clamp stroke		20	20	25	30	30
Cylinder capacity	Clamp	2.2 cm ³	3.9 cm ³	7.2 cm ³	16.7 cm ³	24.6 cm ³
	Unclamp	5.1 cm ³	9.3 cm ³	17.7 cm ³	36.4 cm ³	58.7 cm ³
A		137.3	151.8	179.8	215.6	241.4
J		65.8	73.8	89.3	104.1	116.9
K		71.5	78	90.5	111.5	124.5
M		26.3	27.8	34.3	41.1	43.4

- This diagram indicates unclamped condition.
- Refer to specifications (page → 4), dimensions (page → 8) for specifications and dimensions of products that are not listed on this diagram.

Specifications

Size	Option code
02	KS : Taper sleeve
04	
06 –	KN : Perfect nut
10	
16	KNR : Perfect release nut

Taper sleeve and perfect release nut can not be combined.
 ■ indicates made to order.

Taper sleeve

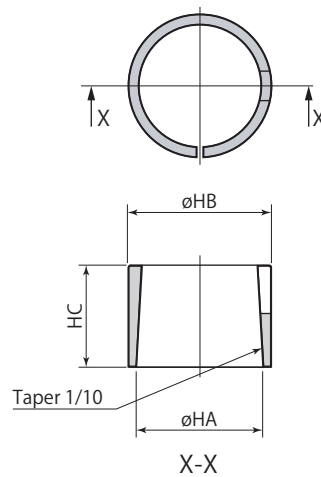

Clamp arm details

Not using taper sleeve

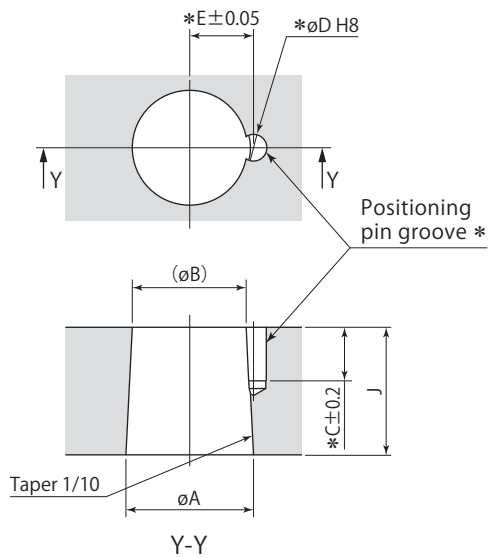

Using taper sleeve

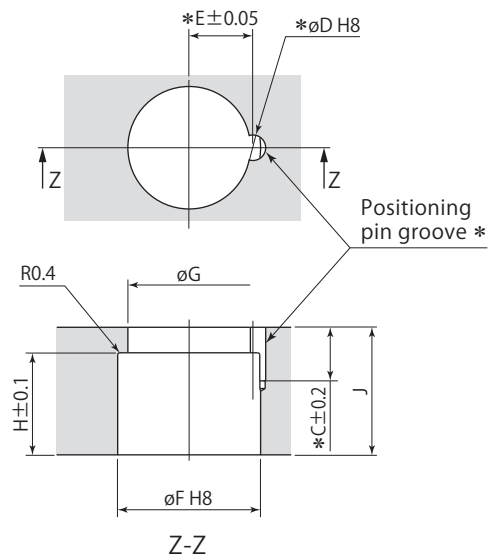

* : No need to machine the pin groove (C, ϕD , E) unless positioning pin is used for the arm.
 The positioning pin enables a clamp arm to locate on the clamp firmly and easily.

Taper sleeve	CTH02-KS	CTH04-KS	CTH06-KS	CTH10-KS	CTH16-KS
Applicable swing clamp	CTK02	CTK04	CTK06	CTK10	CTK16
ϕHA	12	16	20	25	32
ϕHB	14	18	22	28	36
HC	9.5	11	13	16	22
ϕA	12 $\begin{smallmatrix} -0.016 \\ -0.034 \end{smallmatrix}$	16 $\begin{smallmatrix} -0.016 \\ -0.034 \end{smallmatrix}$	20 $\begin{smallmatrix} -0.020 \\ -0.041 \end{smallmatrix}$	25 $\begin{smallmatrix} -0.020 \\ -0.041 \end{smallmatrix}$	32 $\begin{smallmatrix} -0.025 \\ -0.050 \end{smallmatrix}$
ϕB	10.8	14.6	18.4	23.1	29.5
C	6.5	8.5	10.5	12.5	12.5
ϕD (pin groove diameter)	2.5 $\begin{smallmatrix} +0.014 \\ 0 \end{smallmatrix}$	3 $\begin{smallmatrix} +0.014 \\ 0 \end{smallmatrix}$	4 $\begin{smallmatrix} +0.018 \\ 0 \end{smallmatrix}$	5 $\begin{smallmatrix} +0.018 \\ 0 \end{smallmatrix}$	6 $\begin{smallmatrix} +0.018 \\ 0 \end{smallmatrix}$
E	6.05	8.1	10.1	12.6	16.1
ϕF	14 $\begin{smallmatrix} +0.027 \\ 0 \end{smallmatrix}$	18 $\begin{smallmatrix} +0.027 \\ 0 \end{smallmatrix}$	22 $\begin{smallmatrix} +0.033 \\ 0 \end{smallmatrix}$	28 $\begin{smallmatrix} +0.033 \\ 0 \end{smallmatrix}$	36 $\begin{smallmatrix} +0.039 \\ 0 \end{smallmatrix}$
ϕG	11.5	15	19	23.5	30
H	9.5	11	13	16	22
J	12	14	16	19	25

mm