

Control unit model **HCD□H-W**

This is a hydraulic control unit that is air driven and manually operated, combining non-leak valve with non-leak feature (zero oil leaks), which is essential for hydraulic clamps, and Pascal pump. Since two hydraulic circuits can be operated and controlled alternately, it is best suited hydraulic pressure source for double acting clamps. Pascal pump stops pumping once circuit pressure has been attained and retains the pressure. Furthermore, since there is hardly any temperature fluctuation of working fluid, there is no need for any auxiliary pressure equipment.

Model	HCD2H-W	HCD3H-W
Pascal pump	X6308U-C	X6310U-C
Discharge oil pressure*1	MPa 8.7-26.1	5.55-16.65
Set air pressure	MPa 0.2-0.5	
Unloaded oil discharge amount	L/min	Refer to <b>page → 165</b> for performance diagram.
Tank capacity*2	L	H.L. 2.7 L.L. 1.9
Operating temperature	°C	5-60
Fluid used	General mineral based hydraulic oil (ISO-VG32 equivalent)	
Mass	kg	23

\*1: Ask for consultation on specifications that exceed discharge oil pressure range.  
 \*2: Oil level in the tank should be always between H.L. and L.L. of the gauge.

Dimensions

**HCD□H-W** Double acting circuit control unit

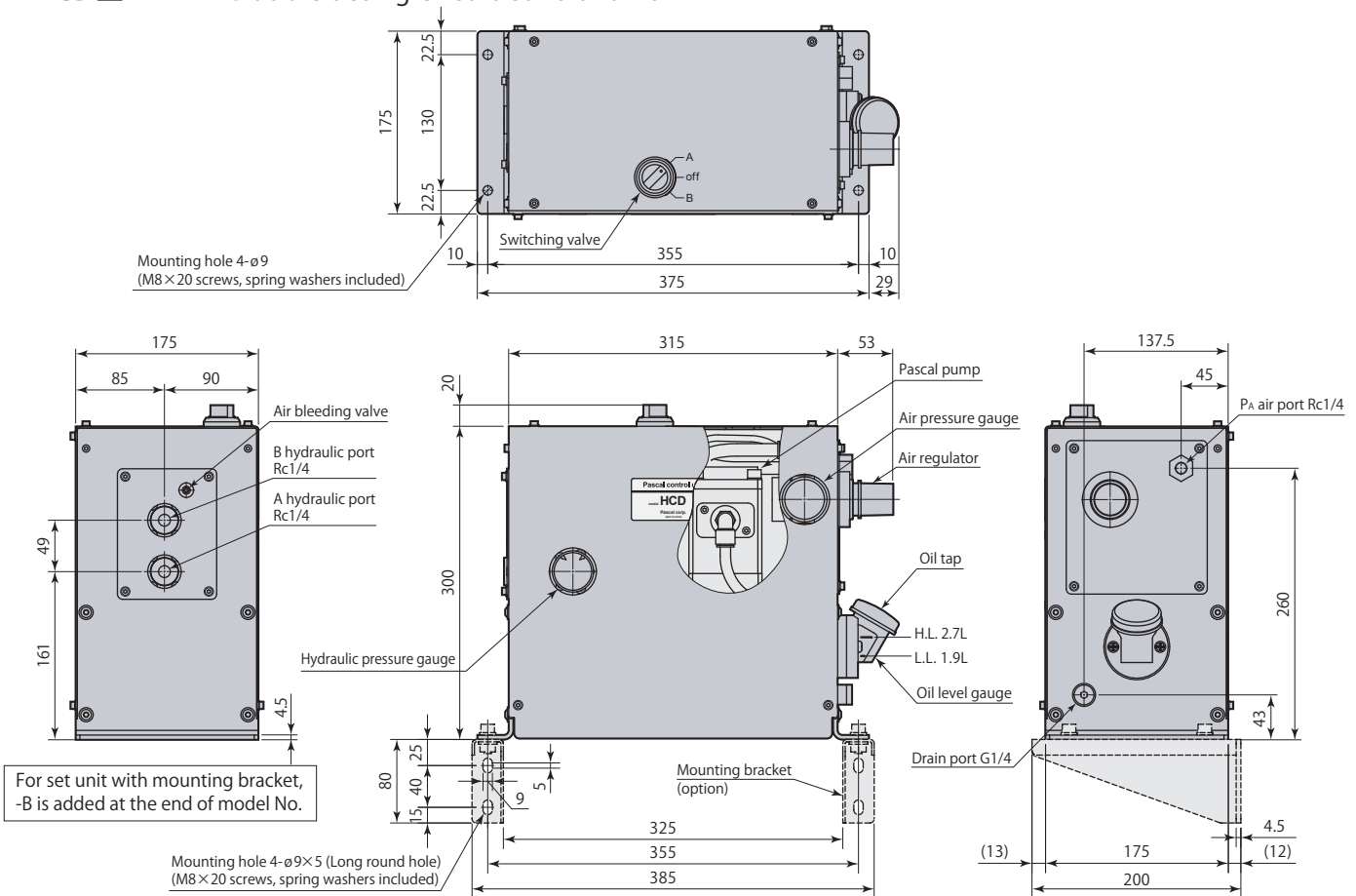

Control unit

HCD Manual operated

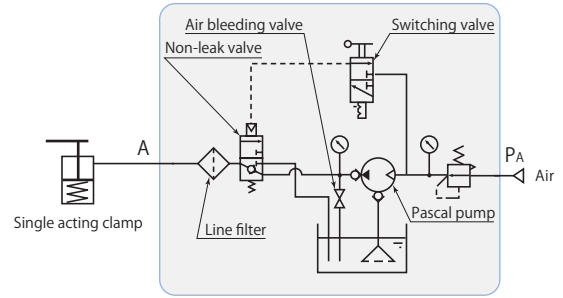

Control unit model HCD□H-S

This is a hydraulic control unit that is air driven and manually operated, combining non-leak valve with non-leak feature (zero oil leaks), which is essential for hydraulic clamps, and Pascal pump. Pascal pump stops pumping once circuit pressure has been attained and retains the pressure. Furthermore, since there is hardly any temperature fluctuation of working fluid, there is no need for any auxiliary pressure equipment.

Model	HCD2H-S	HCD3H-S
Pascal pump	X6308U-C	X6310U-C
Discharge oil pressure*1	MPa 8.7–26.1	5.55–16.65
Set air pressure	MPa 0.2–0.5	
Unloaded oil discharge amount	L/min	Refer to <b>page → 165</b> for performance diagram.
Tank capacity*2	L	H.L. 2.7 L.L. 1.9
Operating temperature	°C	5–60
Fluid used	General mineral based hydraulic oil (ISO-VG32 equivalent)	
Mass	kg	21

\*1: Ask for consultation on specifications that exceed discharge oil pressure range.  
 \*2: Oil level in the tank should be always between H.L. and L.L. of the gauge.

Dimensions

HCD□H-S Single acting circuit control unit

