

7MPa Work clamping system

- CTU CTT
- CLU CLT
- CNA CMC CMD
- CSU CST CSN CSY CSK
- CEK CVH
- VCB VCP VHD VRG VEF WPB WPC
- HCD HCS HCT X63 WRA WRB

Refer to separate catalog for details.



Expansion clamp

- CGC
- CGT
- CGU
- CGE
- CGY

Refer to separate catalog for details.



7MPa Sensing clamp

- CTM
- CTN
- CLM
- CLN
- CNB

Refer to separate catalog for details.

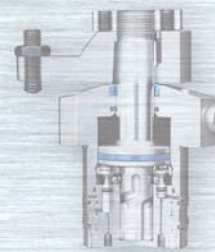

Pal system

- CPC
- CPH
- CPY
- CPK
- WVP



air Work clamping system

- CTX
- CTY
- CLX
- CLY
- CSS
- CSX

Refer to separate catalog for details.

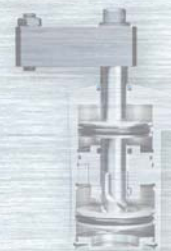

35MPa Work clamping system

- CTK CTW CTV
- CLW CLV
- CSW CSV
- WVP
- VCB VCP VHD VRG VEF WPC
- HCD HCS HCT X63

Refer to separate catalog for details.

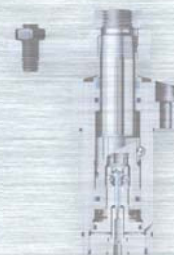

Pal system



Pallet clamp
CPC
Spring clamp

7MPa
Single acting
Page → 14



Pallet clamp
CPH
Hydraulic clamp

7MPa
Double acting
Page → 20



Locate ring
CPS

Page → 26



Pallet clamp
CPY
Air clamp Dual cylinder model

air
Double acting
Page → 40



Locate ring
CPS

Page → 46



Pal fix
CPK
Manual clamp

Manual
Page → 64



Pal coupler
WVP-2B
Oil & air

25MPa
Page → 78



Pal coupler
WVP-3D
Air & coolant

1MPa
Page → 79



Pal coupler
WVP-2F
Oil & air

7MPa
Page → 84



Pal coupler
WVP-3G
Air & coolant

1MPa
Page → 86



Pal coupler
WVP-1F
Air

1MPa
Page → 88



Non-leak coupler
WVP-2H
Oil

7MPa
Page → 90



Non-leak coupler
WVP-2S
Oil

7MPa
Page → 92



Pilot coupler
WVP-2E
Oil

7MPa
Page → 94

Pal system

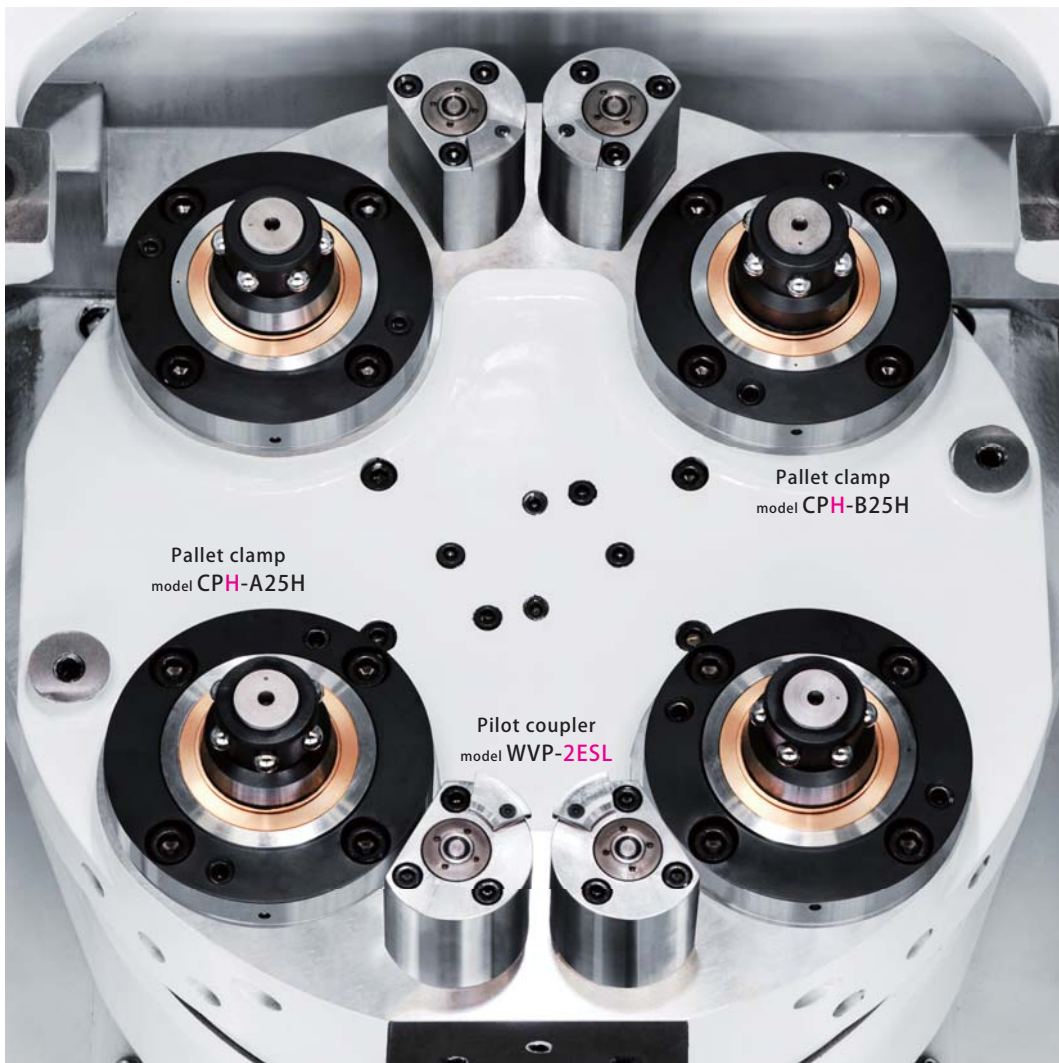

Standard Pal system

Pal system that changes pallet by reducing hydraulic (air) clamp circuit pressure to zero

Pal coupler fitting stroke 1 mm

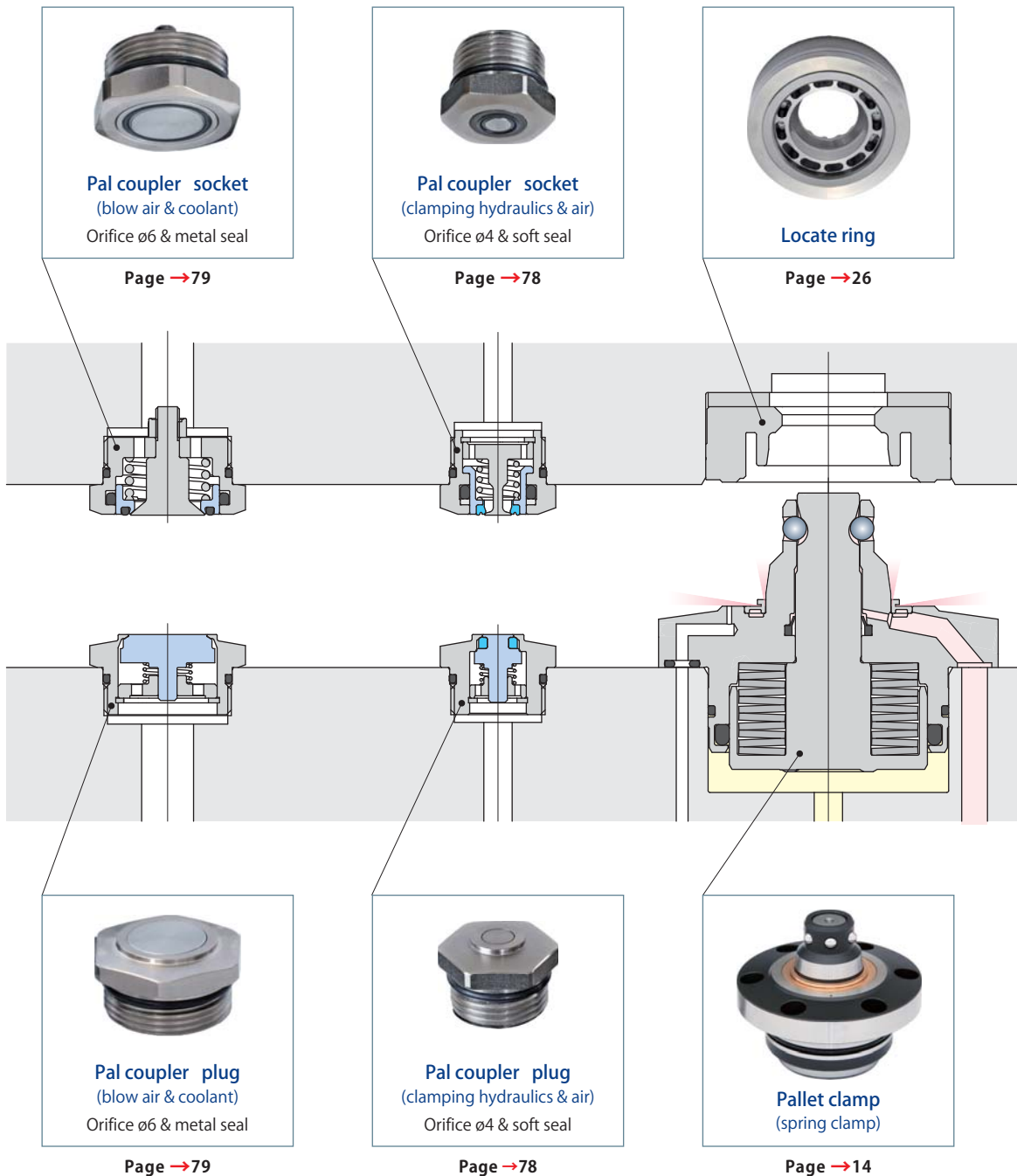

Select one of either spring clamp (model CPC), hydraulic clamp (model CPH) or air clamp (model CPY) .

Pallet change

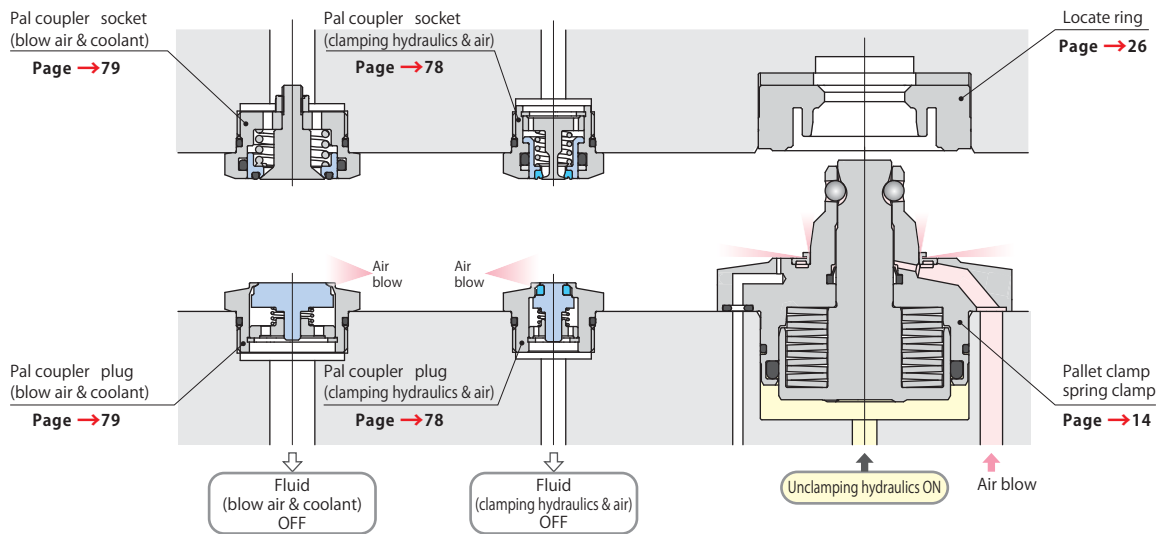

Pallet unclamped and coupler disconnected

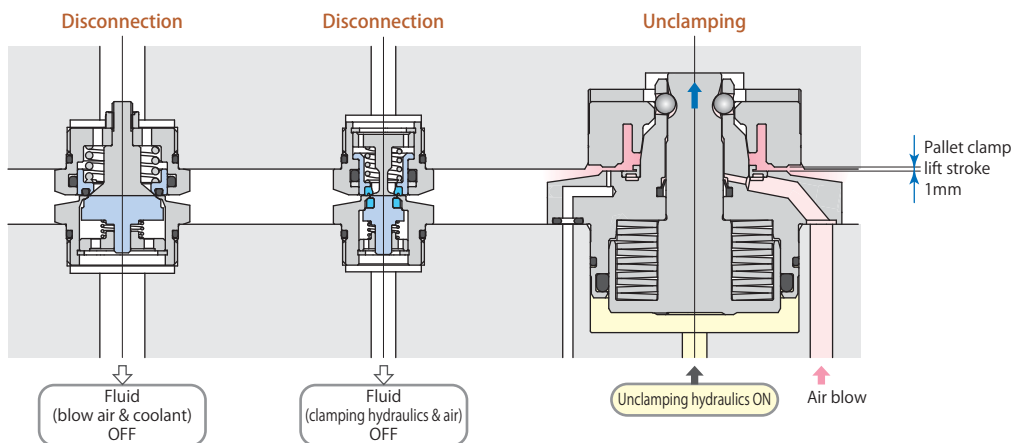

When unclamping pallet, coupler disconnects due to lift stroke of pallet clamp.

Pallet clamped and coupler connected

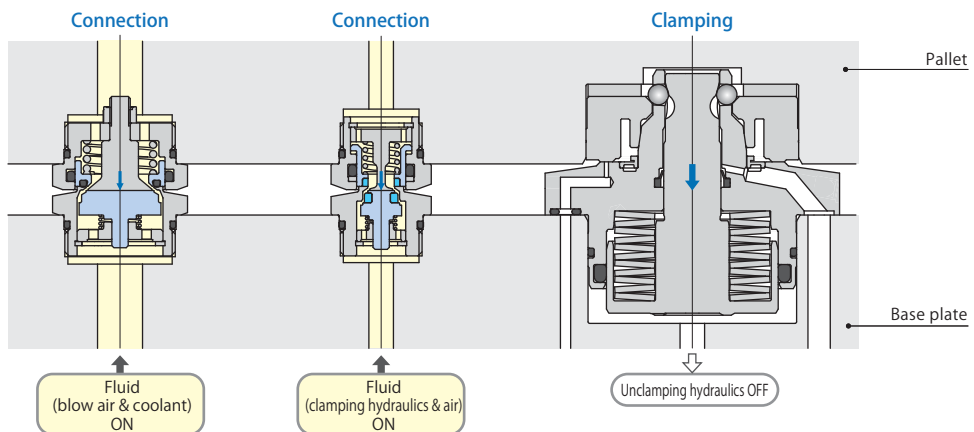

When clamping pallet, coupler connects due to clamp stroke of pallet clamp.

Pallet changer Pal system

Pal system capable of changing pallets while maintaining hydraulic clamp in clamp condition

Non-leak coupler fitting stroke 4 mm

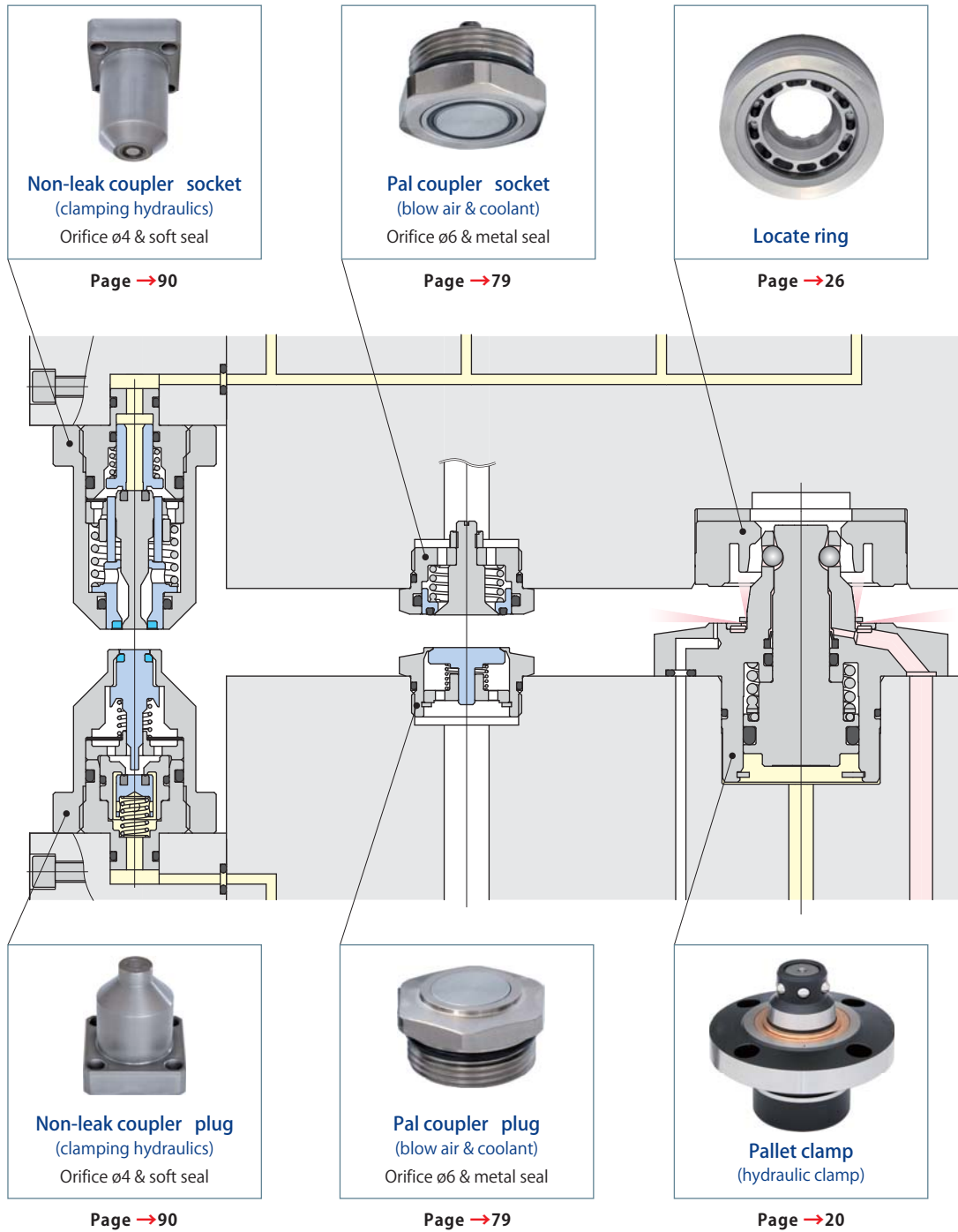

Select one of either spring clamp (model CPC), hydraulic clamp (model CPH) or air clamp (model CPY) .

Pallet unclamped and coupler disconnected

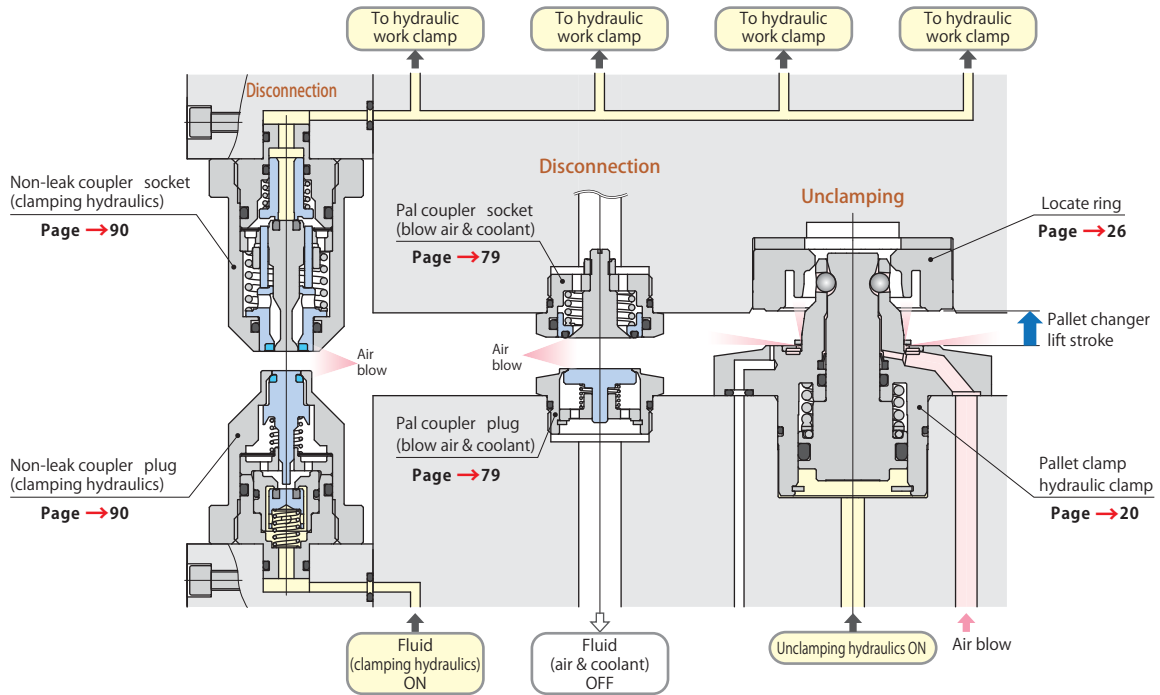

When unclamping pallet, coupler disconnects due to lift stroke of pallet changer, with hydraulics sustained.

Pallet clamped and coupler connected

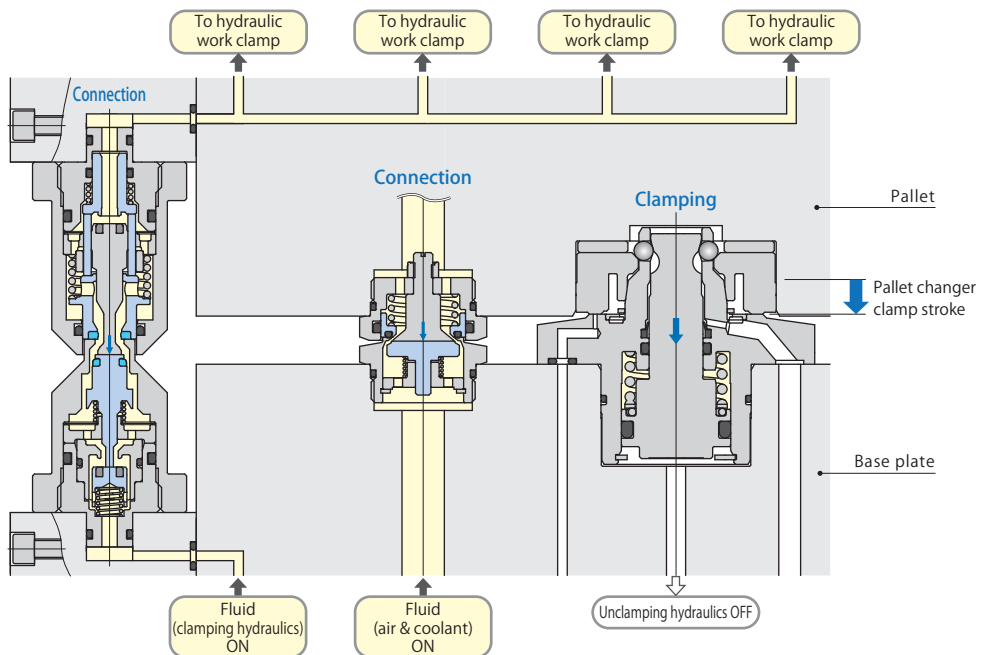

When clamping pallet, coupler connects due to clamp stroke of pallet changer, with hydraulics sustained.

Pallet clamp

7 MPa

Locate ring
Pallet lower surface mounting
model **CPS-ED**



Locate ring
Pallet upper surface mounting
model **CPS-ET**



Spring clamp
model **CPC-A**



Hydraulic clamp
model **CPH-A**

Pallet setting

- Bring the pallet above the base plate. After positioning, lower the pallet. Pallet descends along guides (A) & (B) and stops after coming into contact with piston rod upper surface (C), making pallet setting easy. Furthermore, since locate ring does not come into contact with seating surface of pallet clamp, damages on seating surface can be prevented during pallet exchanges.

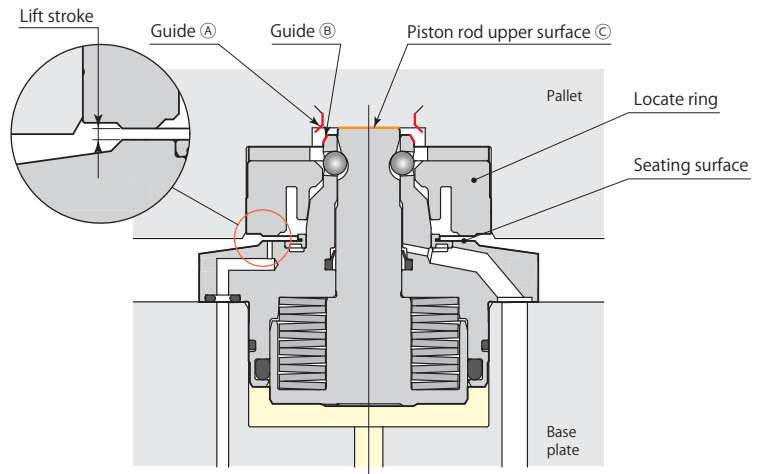

XY axes positioning

- When the unclamping hydraulic pressure is released, piston rod goes down by spring force* and radially extends the steel balls, pulling down the locate ring. The locate ring and taper cone at pallet clamp come into contact.

* : For only model CPC. The piston rod in CPH goes down by the hydraulic force, the piston rod in CPY goes down by air force.

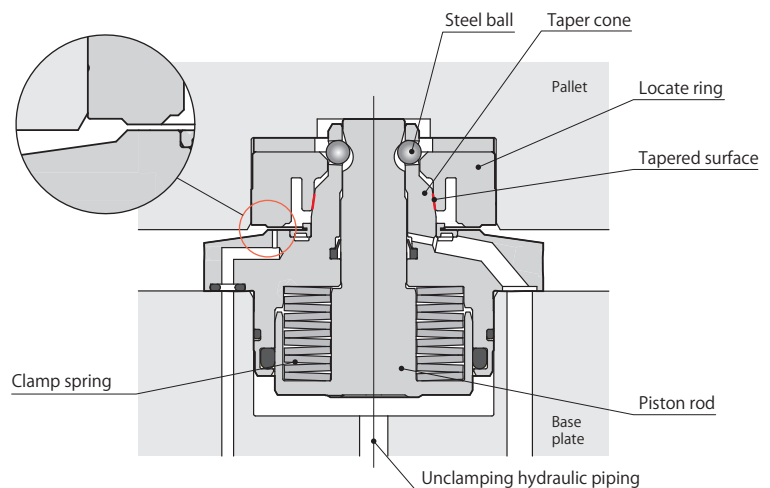

XYZ axes positioning (clamping is completed)

- The locate ring that is attached to tapered surface of taper cone is expanded and deformed in radial direction to firmly position X axis and Y axis. Locate ring is attached to seating surface and positions Z axis. The positioning of X, Y and Z axes by tapered surface and seating surface completes the XYZ positioning (dual surface positioning).

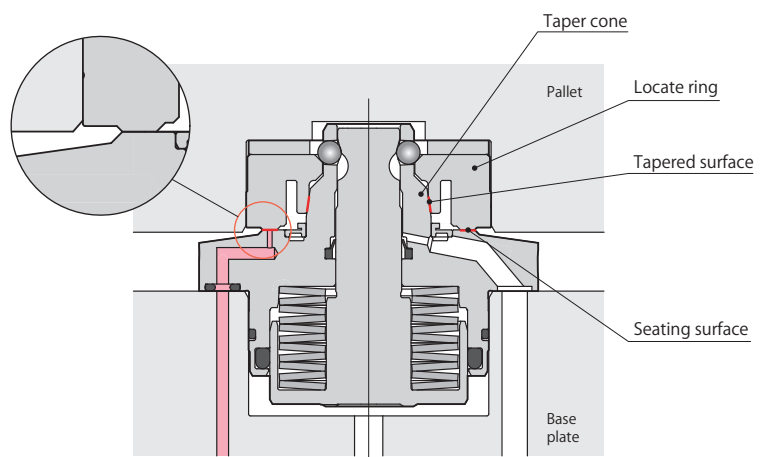

High repeatability and retention of accuracy

- Air blows out of wide slits laid out over circumference to tapered surface and seating surface directly for ensuring prevention of foreign substances.
- Since seating detection function is provided, it is possible to prevent operation with incomplete clamping due to insertion of metal chips.
- Rust proofing has been implemented to locate ring in order to prevent rusting while pallet is in storage or on standby.
- All cutting and turning components are machined using high precision grinding machines. Internal and external surfaces have been simultaneously machined in temperature controlled rooms.
- Completed components are under strict quality control program in order to maintain horizontal accuracy of pallet surfaces when eventually mounted on machines.

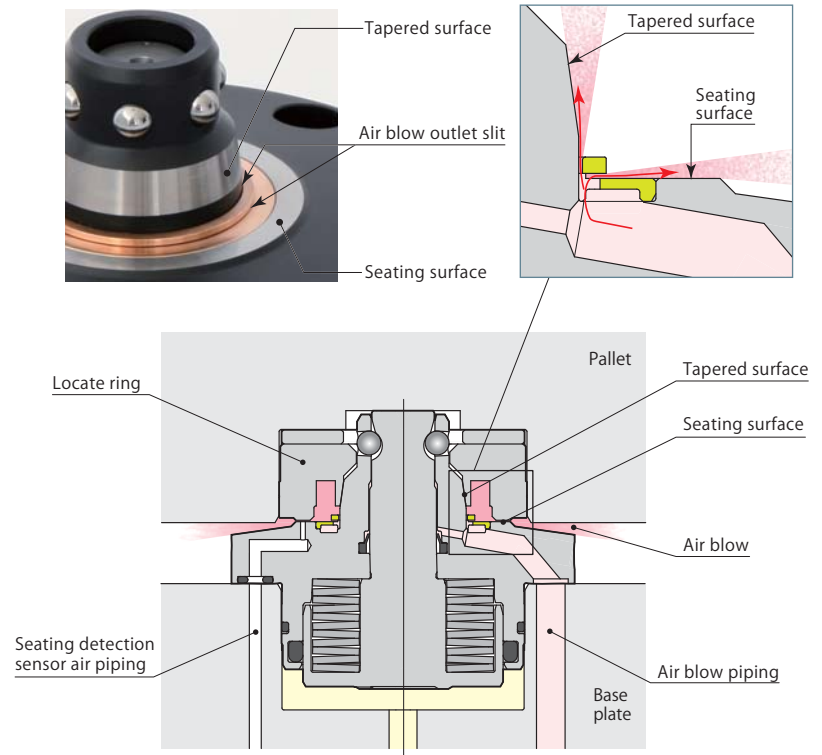

Taper angle that withstands large cutting thrust force

- Pallet clamp has tapered surface angle that is close to perpendicular, which allows for stable clamping with minimal impact from thrust exerted during cutting process. This is particularly effective in inhibiting chatter when cutting process at higher locations on the pallet, which improves processing conditions for high-speed cutting and heavy duty cutting.

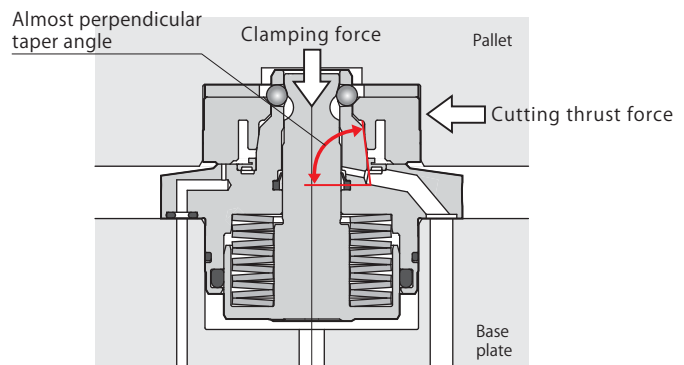

Rectangular flange (made to order)

- A rectangular flange, created by cutting out mounting flange portion of pallet clamp body, is available (made to order). Inquire for details.

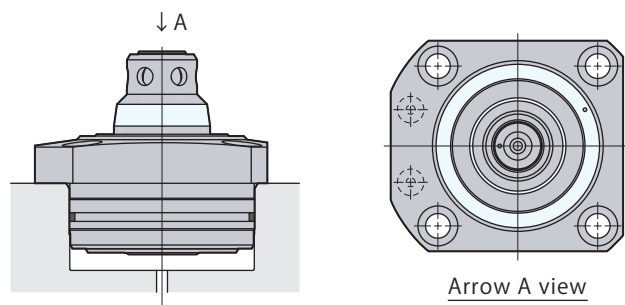

Solid tapering method with superior durability and repeatability

- Solid tapering type locate ring has no sliding portion for its positioning structure. Advantageous in terms of durability as well as in keeping the initial repeatability for a long time.
 - When positioning X & Y axes, the taper portion evenly and elastically deforms outwards to offer highly accurate positioning. Furthermore, the taper portion has no slits, eliminating accuracy issues relating to positioning due to intrusion of metal chips into slits.
 - Elastic deformation of taper portion is conducted evenly due to the integrated ribs that are evenly distributed in the radial direction providing high clamping rigidity.
- *:No pockets are provided with the model CPS-E25 and CPS-E40 because elastic deformation is easily obtainable at tapered part due to its body size.

Solid tapering type
model CPS-E

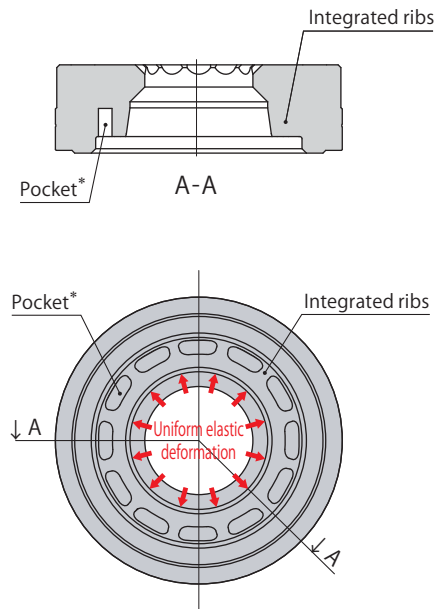

Specialized design reduces surface contact pressure and prevents deterioration of clamping force

- Pallet clamp enhances output of clamp piston and firmly secures pallet. Steel ball contacting portions, where high surface pressure is exerted, have been designed in a special form that prevents indentation marking, which can deteriorate the clamping force, thereby making it possible to firmly fix pallets over long periods of time.

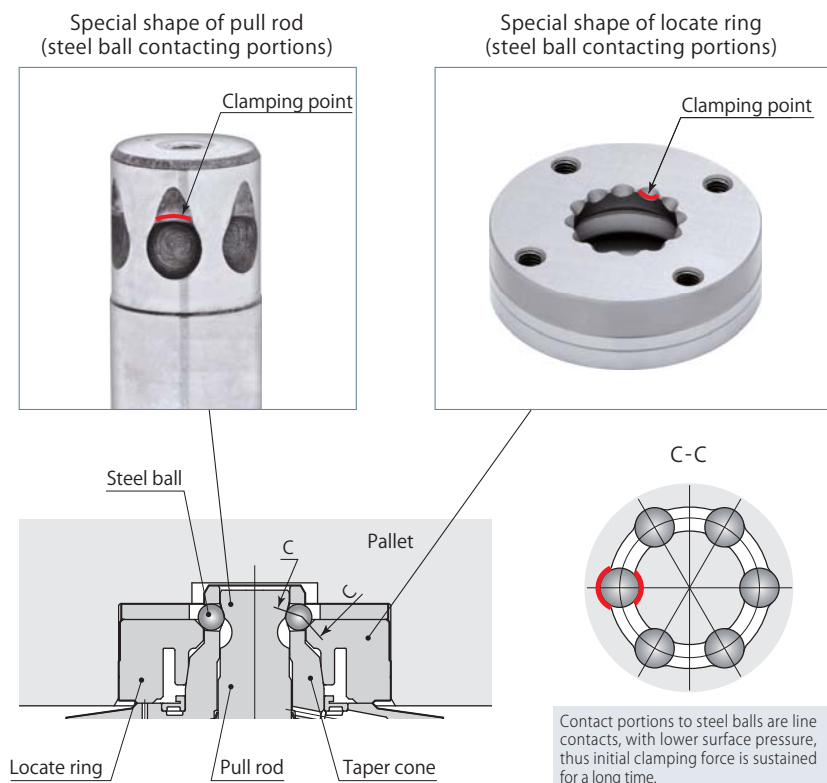

Exchanges of jigs and workpieces are easy with Pal system

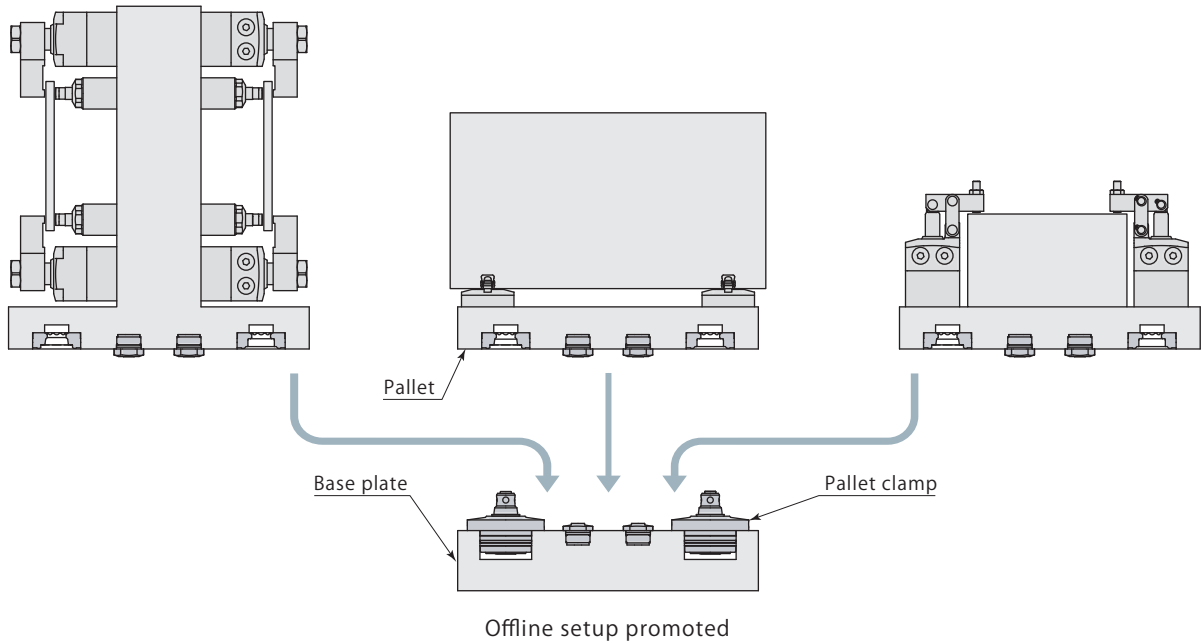

- Implementation of Pal system makes it possible to perform setting of workpiece on jigs of machine table accurately and significantly reduces setup time that was previously necessary for alignment.

Multifaceted machining with high accuracy is easy

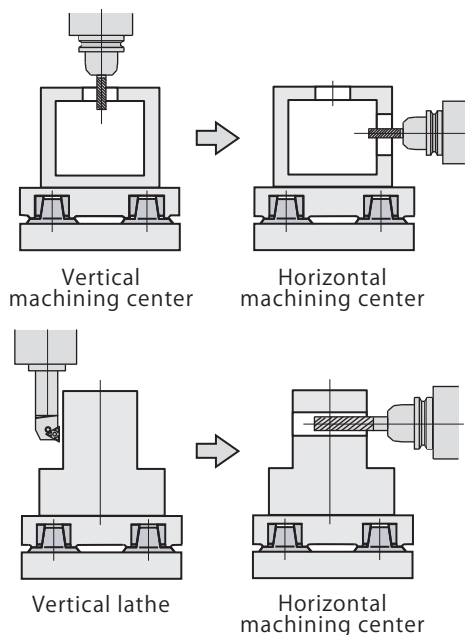

- Since workpieces do not have to be dismantled from pallets, continuous operations through multiple machines are possible. Highly accurate, multifaceted machining is possible with the Pal system.

Process division is easy (pallet transfer method)

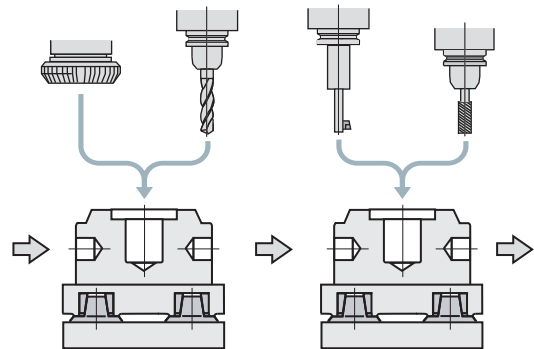

- Highly accurate positioning of Pal system makes it possible to distribute processes. This advantage allows a flexible allocation of machining process, which needs a very high accuracy. This flexibility makes it easier to unify tact time among all machines, leading to even distribution of load among machines to raise productivity.
- With pallet transfer method, mixed production of workpieces can be done easily.
- Workpieces are fixed onto the pallet before transferring, thus clamp time is short and problems relating to clamping can be mitigated at each machine.

Pallet clamp configuration pattern 1

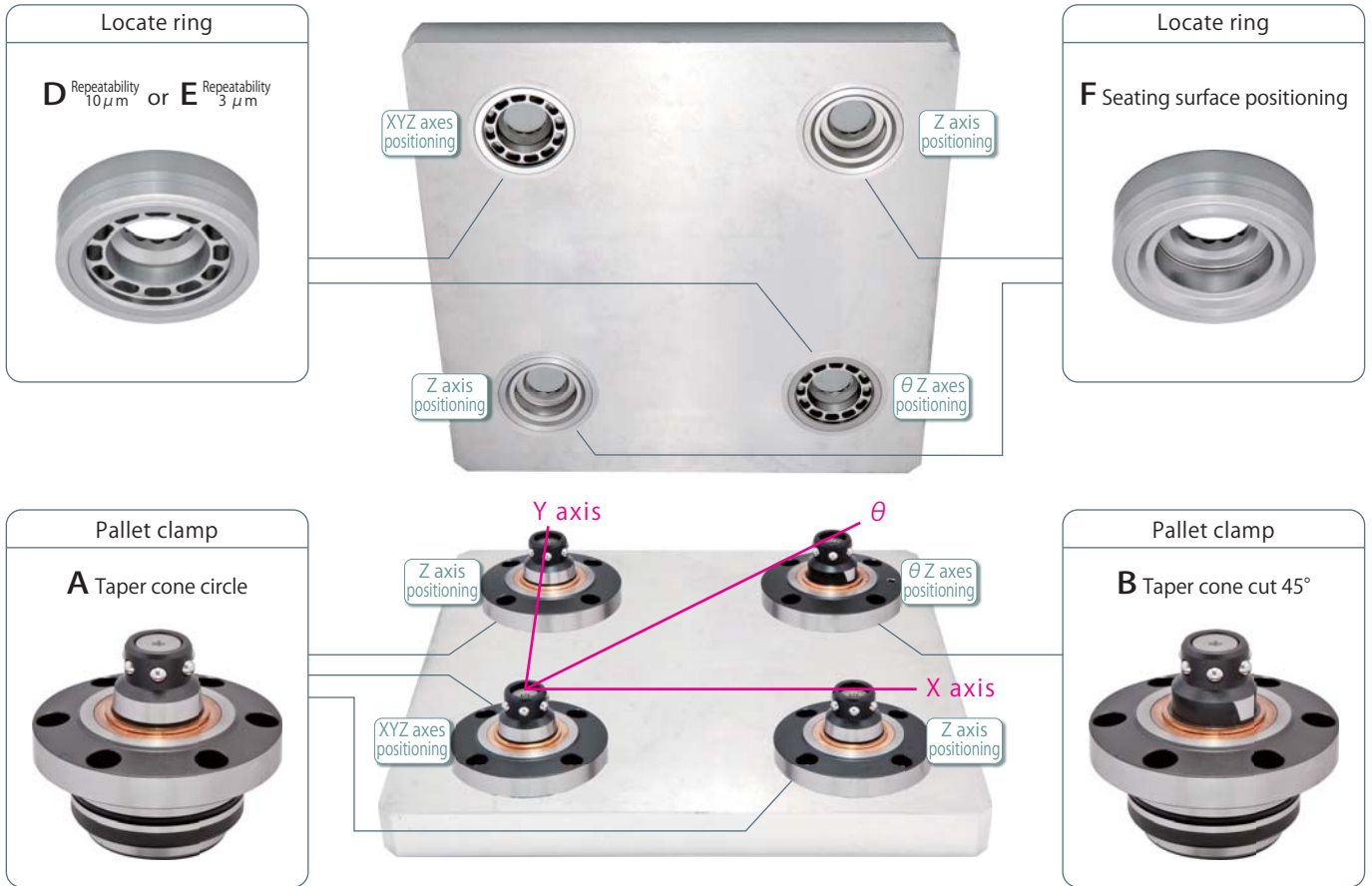

θ X Y axes positioning by tapered surface

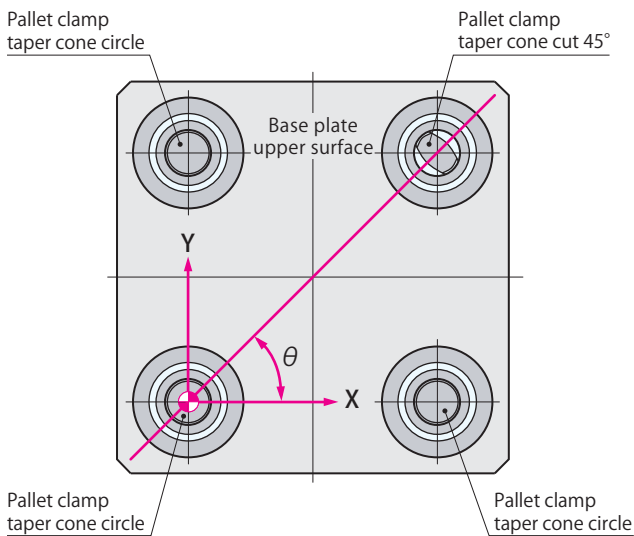

Z axis positioning by seating surface

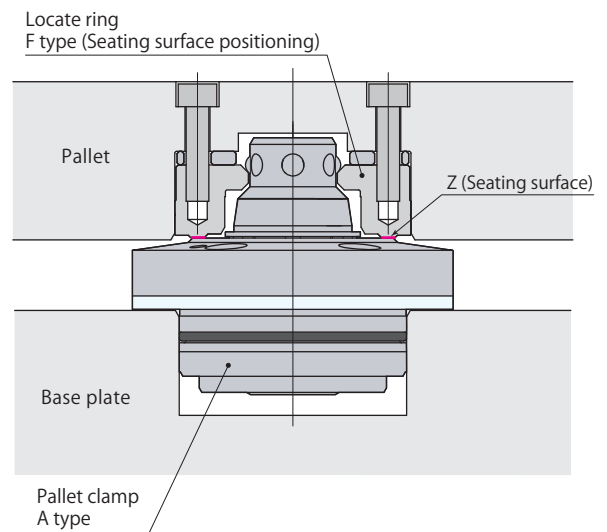

The pitch error between XYZ axes positioning pallet clamp and θ Z axes positioning pallet clamp is tolerated by cut type taper cone even under thermal change conditions.

Since Z axis is positioned by 4 points of seating surface with no effect from pitch error, surface accuracy of pallet is sustained at high levels.

Pallet clamp configuration pattern 2

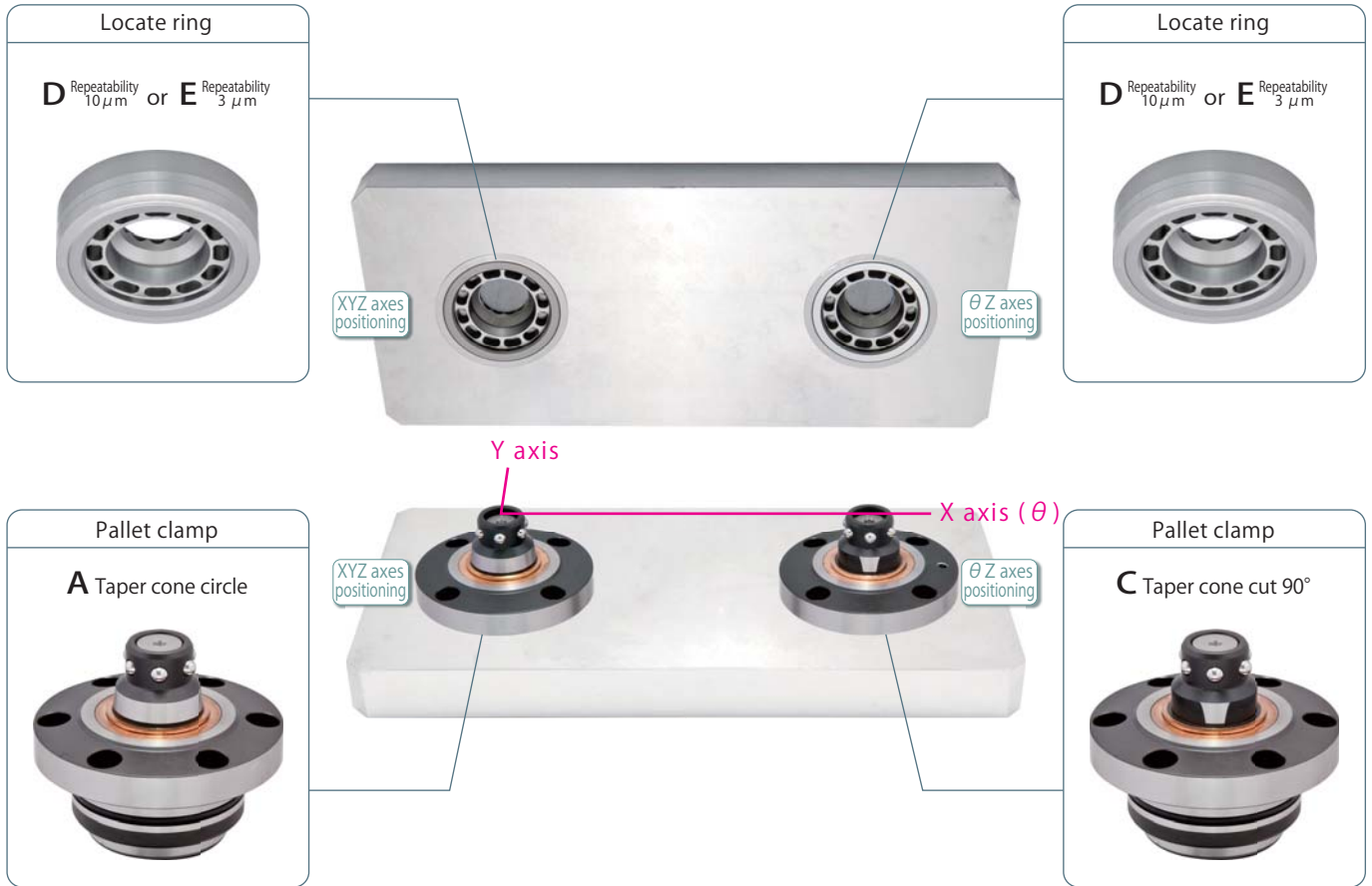

θ X Y axes positioning by tapered surface

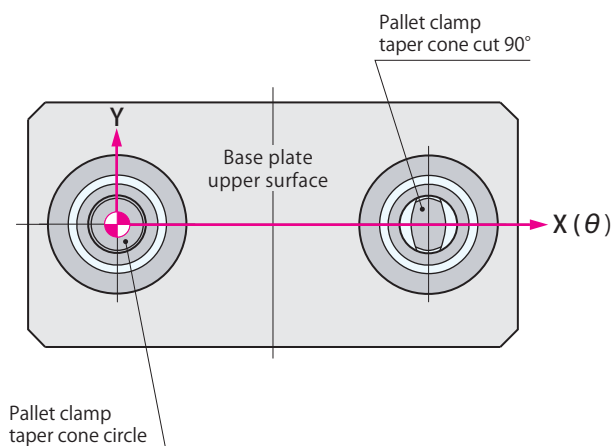

Z axis positioning by seating surface

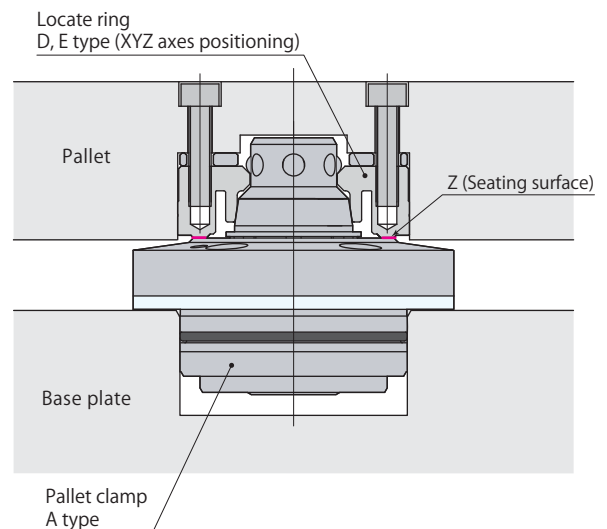

The pitch error between XYZ axes positioning pallet clamp and θ Z axes positioning pallet clamp is tolerated by cut type taper cone even under thermal change conditions.

Since Z axis is positioned by 2 points of seating surface with no effect from pitch error, surface accuracy of pallet is sustained at high levels.

Spring clamp

model CPC-□□H PAT.



Highly rigid pallet clamp and repeatability of $3\ \mu\text{m}$ with dual surface contact
The mechanical clamp with high output, long-life belleville spring

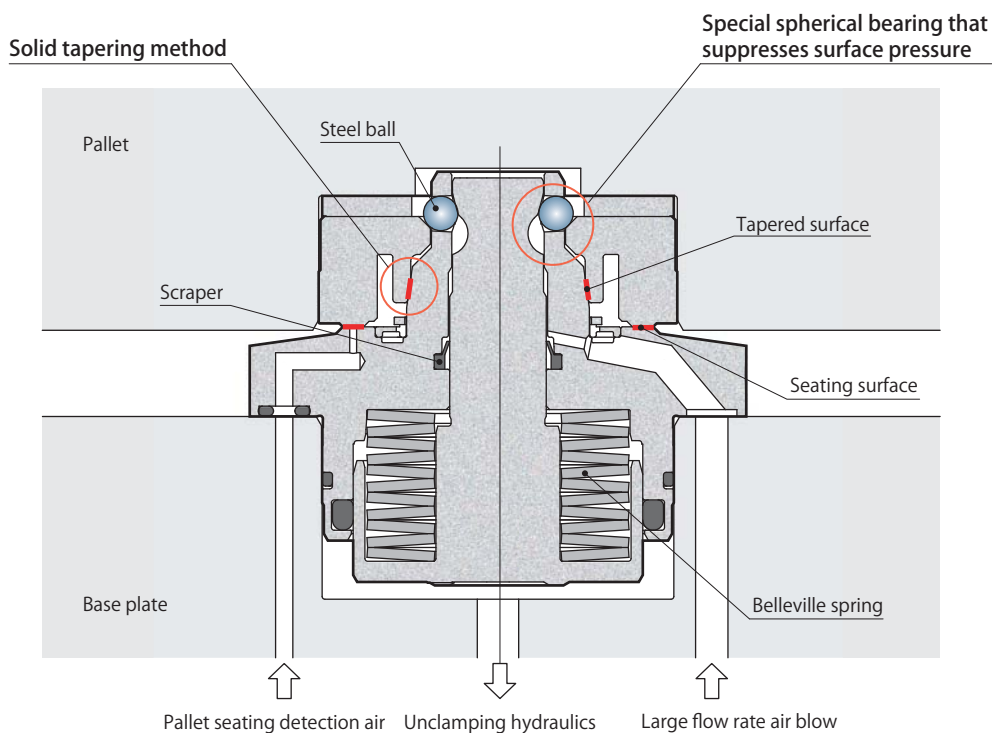

Specifications page → 15

Dimensions page → 16

Mounting details page → 18

Locate ring page → 26

Specifications

	Type	Size	
CPC —	A : Taper cone circle	03	H
	B : Taper cone cut 45°	06	
	C : Taper cone cut 90°	10	
	S : Shim	16	
		25	
		40	

● Be sure to specify models and serial numbers when placing repeat orders. (Models and serial numbers are laser marked on clamps; For shim, same models and serial numbers as clamps may be specified.)

■ indicates made to order.

Model		CPC-□03H	CPC-□06H	CPC-□10H	CPC-□16H	CPC-□25H	CPC-□40H	
Clamping force*1	kN	4.0	6.0	10.0	16.0	25.0	40.0	
Cylinder capacity (unclamp)*1	cm ³	4.0	6.1	14.1	28.7	49.6	77.9	
Full stroke	mm	4.4	4.4	5.0	6.5	7.0	7.5	
Clamp stroke	mm	2.4	2.4	3.0	4.0	4.5	5.0	
Safety stroke	mm	2.0	2.0	2.0	2.5	2.5	2.5	
Lift stroke*2	mm	1						
Max. allowable eccentricity for pallet setting	mm	±1.0	±1.5	±2.0	±2.5	±3.5	±4.0	
Lift force*1*3	Hydraulic pressure 3.5MPa	kN	0.4	0.4	1.5	3.2	4.6	4.6
	Hydraulic pressure 5MPa	kN	1.8	2.5	5.7	9.8	15.3	20.1
	Hydraulic pressure 7MPa	kN	3.6	5.2	11.4	18.7	29.4	40.9
Lift force calculation (P: Unclamping hydraulic pressure MPa)*1*3			$0.91 \times P - 2.73$	$1.39 \times P - 4.46$	$2.83 \times P - 8.42$	$4.42 \times P - 12.25$	$7.09 \times P - 20.18$	$10.39 \times P - 31.80$
Max. allowable load (including a pallet)*4	Horizontal mounting	kN	3.0	8.0	15.0	25.0	35.0	50.0
	Vertical mounting	kN	0.5	1.5	2.5	4.0	5.0	7.5
Mass*1	kg	0.5	0.7	1.6	3.0	5.6	9.6	
Recommended tightening torque of mounting screws*5 N·m			7	7	12	29	57	100

- Pressure range: 3.5–7 MPa ● Proof pressure: 10.5 MPa ● Operating temperature: 0–70 °C
- Fluid used: General mineral based hydraulic oil (ISO-VG32 equivalent) ● Recommended air blow pressure: 0.3–0.5 MPa
- *1: The figure indicates one piece of clamp. *2: This is the amount for lifting pallet when unclamping.
- *3: Set the hydraulic pressure so that the lift force is equal to or greater than the max. allowable load.
- *4: This is maximum allowable load of pallet, regardless of how many clamps are used. *5: ISO R898 class 12.9

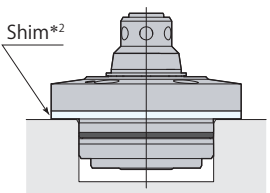
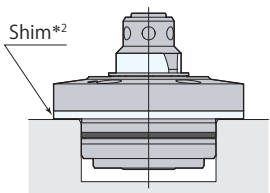
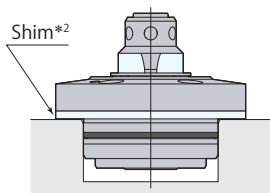
Pallet clamp type	A Taper cone circle	B *3 Taper cone cut 45°	C *3 Taper cone cut 90°
Spring clamp model CPC *1	 model CPC-A□H	 model CPC-B□H	 model CPC-C□H

- *1: Spring clamp model CPC and hydraulic clamp model CPH (page →20) cannot be used together.
- *2: Shim of pallet clamp can be used when heights of mounted clamps vary. (option)
- *3: Taper cone cut can be selected from B type or C type.

Dimensions

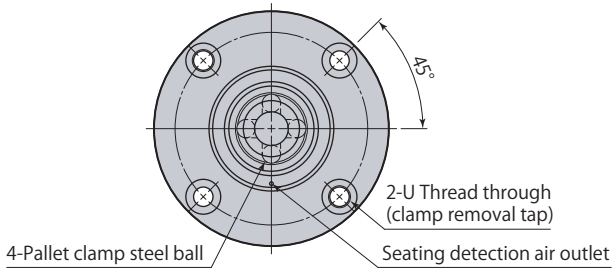

CPC-A03H

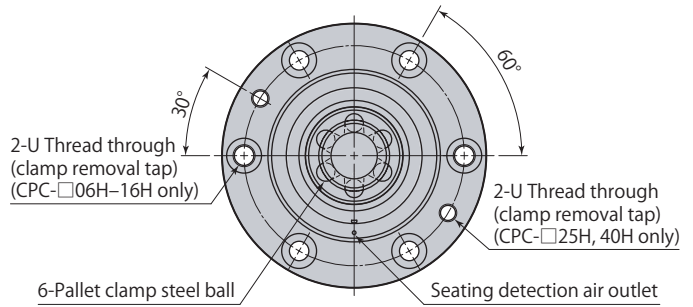

CPC-A06-40H

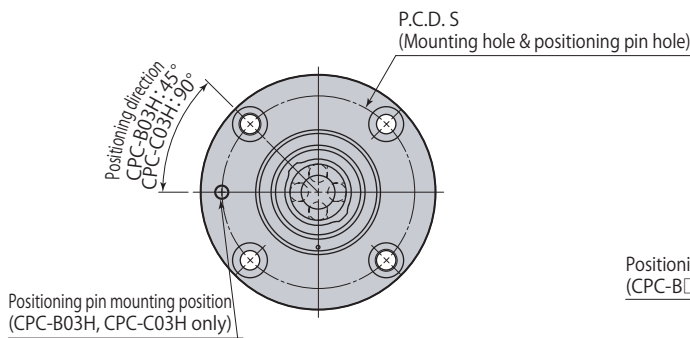

CPC-^B/_C03H

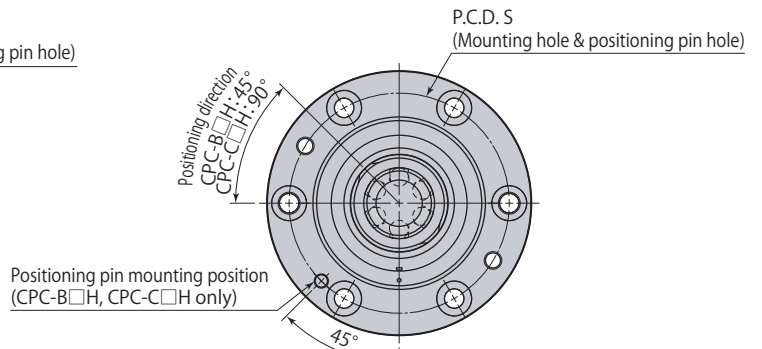

CPC-^B/_C06-40H

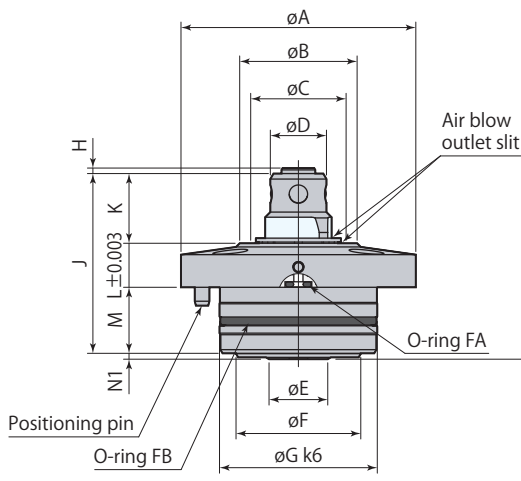

Unclamp

Full stroke

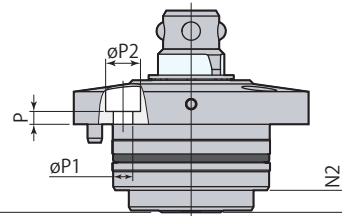

Stroke end

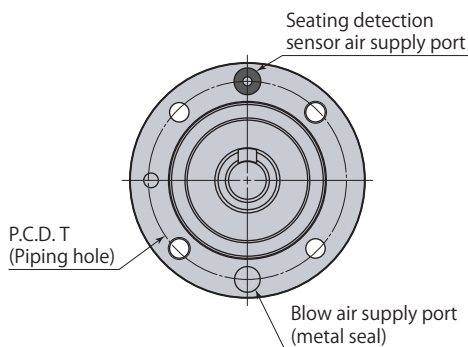

CPC-□03H

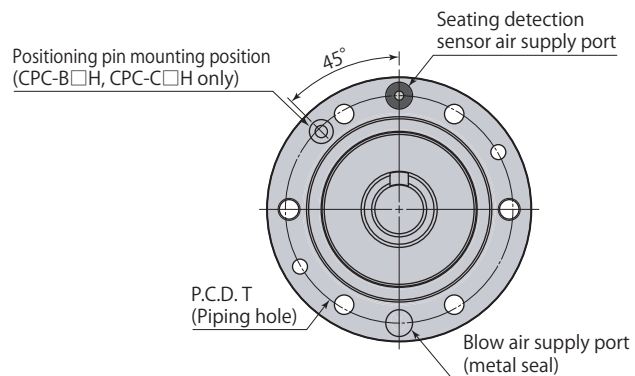

CPC-□06-40H

CPC-□□H	Pallet clamp Spring clamp					7MPa	Single acting
----------------	----------------------------------	--	--	--	--	-------------	----------------------

Model	CPC-□03H	CPC-□06H	CPC-□10H	CPC-□16H	CPC-□25H	CPC-□40H
øA	64	72	100	120	150	175
øB	32	45	48	66	78	94
øC	26	37	40	56	66	78
øD	15.3	19.3	23	29.4	37.3	46
øE	16	19	29	35	45	56
øF	34	42	60	75	95	115
øG	43 ^{+0.018} _{+0.002}	51 ^{+0.021} _{+0.002}	74 ^{+0.021} _{+0.002}	89 ^{+0.025} _{+0.003}	110 ^{+0.025} _{+0.003}	130 ^{+0.028} _{+0.003}
H	1.5	1.5	1.3	1.3	1.3	1.3
J	50.6	57.6	68	85.5	107	129.5
K	19	22.5	26	34	41	48
L	12	13	15	18	22	28
M	18	18	24	27	32	35
N1	1.6	4.1	3	6.5	12	18.5
N2	6	8.5	8	13	19	26
P	3.5	5	4	5	5	7
P1	5.3	5.3	6.8	9	11	14
P2	9.5	9.5	11	14	17.5	20
S	52.5	60	86	104	130	152
T	54	62	86	104	130	152
U	M6×1	M6×1	M8×1.25	M10×1.5	M10×1.5	M12×1.75
O-ring FA (hardness Hs90)	P4	P4	P4	P6	P8	P10
O-ring FB (hardness Hs90)	AS568-029	AS568-032	AS568-147	AS568-152	AS568-155	AS568-158

- Be sure to match up phase of pallet clamp steel balls and locate ring steel ball grooves.
- Positioning direction is the direction in which tapered surface has not been cut.
- Use øA, which has been ground at the same time as tapered surface, for positioning measurement after mounting.
- Mounting screws are not included.
- Coupler (pages →78–83) recommended when using couplers in a set.
- □□□ dimensions are different from former pallet clamp (model CPC-□□□F).

Mounting details

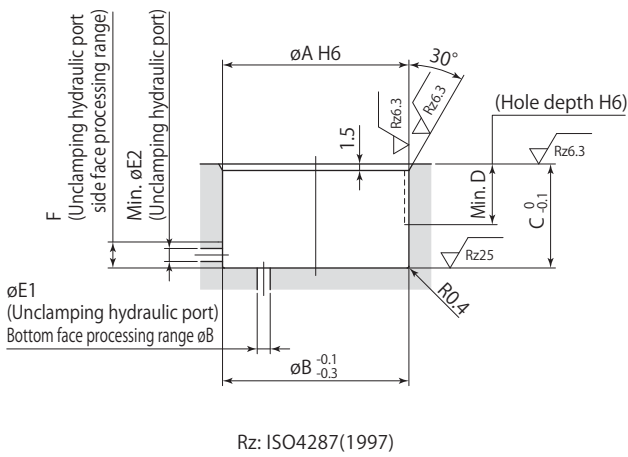
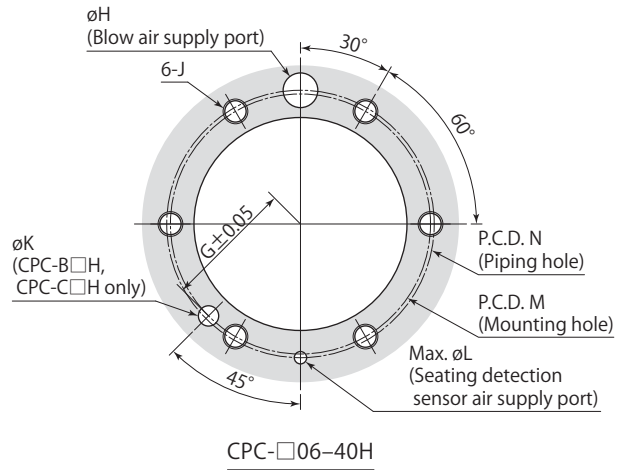
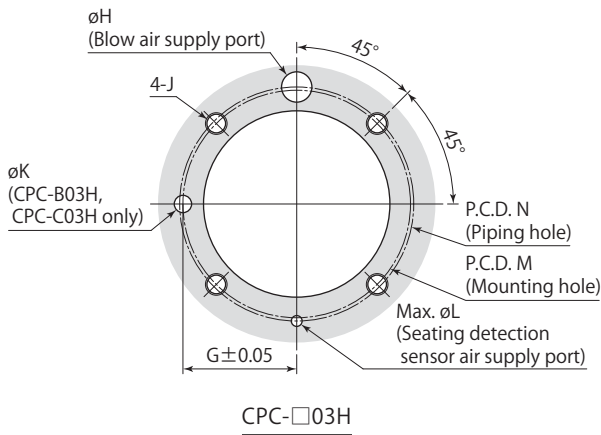

Shim (option)

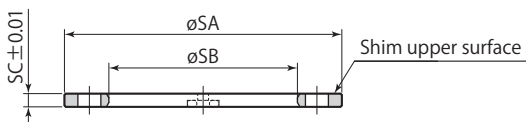
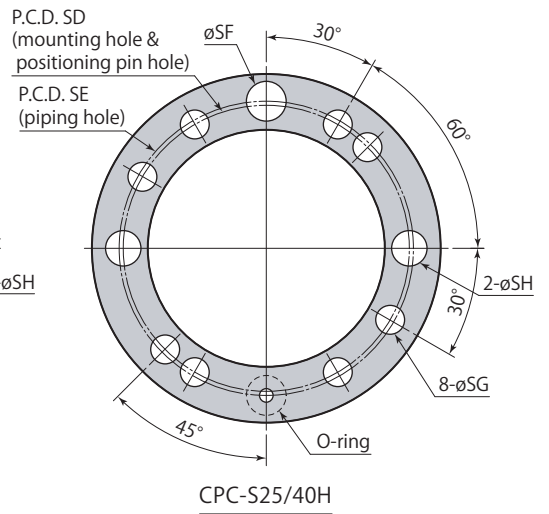
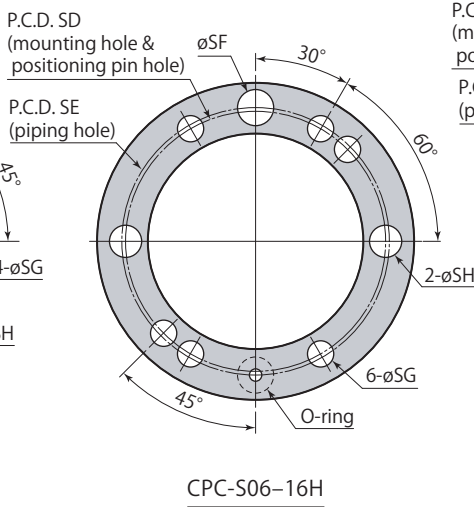
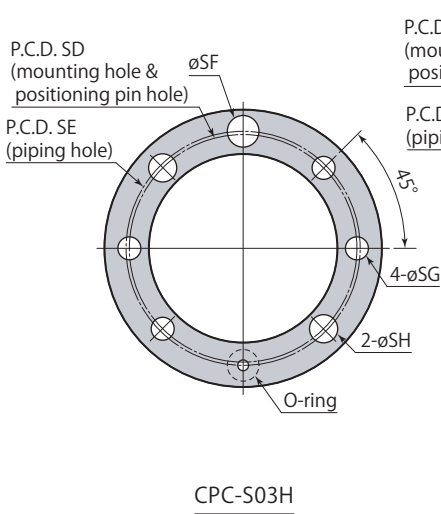

CPC-□□H	Pallet clamp Spring clamp	7MPa	Single acting
----------------	----------------------------------	-------------	----------------------

Model	CPC-□03H	CPC-□06H	CPC-□10H	CPC-□16H	CPC-□25H	CPC-□40H
∅A	43 ^{+0.016} ₀	51 ^{+0.019} ₀	74 ^{+0.019} ₀	89 ^{+0.022} ₀	110 ^{+0.022} ₀	130 ^{+0.025} ₀
∅B	43	51	74	89	110	130
∅E1	3-12	3-15	3-25	3-31	4-39	4-50
∅E2	3	3	3	3	4	4
F	6	8.5	8	13	19	26
G	26.25	30	43	52	65	76
∅H	4.5-7	4.5-7	5.5-8	6-9	7-11	7-13
J	M5	M5	M6	M8	M10	M12
∅L	2.5	2.5	2.5	4	6	8
M	52.5	60	86	104	130	152
N	54	62	86	104	130	152

Not using shim (standard specifications)

C	24	26.5	32	40	51	61
D	14	14	15	15	16	16
∅K	4.1 ^{+0.1} ₀ depth 6	4.1 ^{+0.1} ₀ depth 6	4.1 ^{+0.1} ₀ depth 6	6.1 ^{+0.1} ₀ depth 6	6.1 ^{+0.1} ₀ depth 6	6.1 ^{+0.1} ₀ depth 6

Using shim (shim specifications)

C	21	23.5	29	37	47	57
D	11	11	12	12	12	12
∅K	4.1 ^{+0.1} ₀ depth 4	4.1 ^{+0.1} ₀ depth 4	4.1 ^{+0.1} ₀ depth 4	6.1 ^{+0.1} ₀ depth 4	6.1 ^{+0.1} ₀ depth 4	6.1 ^{+0.1} ₀ depth 4

- Process with shim specification dimensions when shim is attached. Processing with standard specification dimensions will result in clamp damage during full stroke.
- Process either bottom or side surface of unclamping hydraulic port.
- Be sure to match up phase of pallet clamp steel balls and locate ring steel ball grooves.
- dimensions are different from former pallet clamp (model CPC-□□F).

Shim	CPC-S03H	CPC-S06H	CPC-S10H	CPC-S16H	CPC-S25H	CPC-S40H
∅SA	64	72	100	120	150	175
∅SB	43.5	51.5	75	90	111	131
SC	3.05	3.05	3.05	3.05	4.05	4.05
SD	52.5	60	86	104	130	152
SE	54	62	86	104	130	152
∅SF	7.3	7.3	8.2	9.2	11.2	13.2
∅SG	5.3	5.3	6.3	9	11	14
∅SH	6.5	6.5	9	11	11	14
O-ring (hardness Hs90)	P4	P4	P4	P6	P8	P10
Mass	0.04 kg	0.04 kg	0.07 kg	0.10 kg	0.22 kg	0.28 kg

- This diagram indicates dimensions at shipping.
- Adjust thickness of shim by grinding to ensure flatness of pallet.
- Grind shim upper surface (surface without O-ring) to adjust shim.
- dimensions are different from former pallet clamp (model CPC-□□F).

Hydraulic clamp

model CPH-□□H PAT.



Highly rigid pallet clamp and repeatability of 3 μm with dual surface contact
Compact and reliable hydraulic clamp

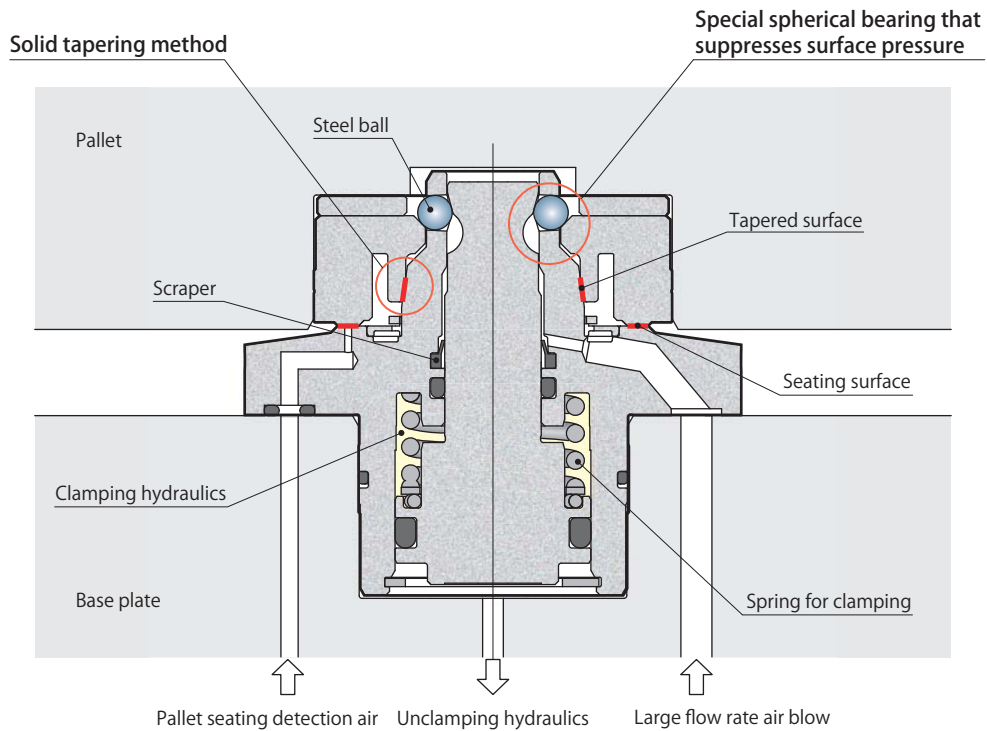

- Specifications page → 21
- Dimensions page → 22
- Mounting details page → 24
- Locate ring page → 26

Pallet clamp
CPH Hydraulic clamp

Specifications

	Type	Size	
CPH —	A : Taper cone circle	03	H
	B : Taper cone cut 45°	06	
	C : Taper cone cut 90°	10	
	S : Shim	16	
		25	
		40	

● Be sure to specify models and serial numbers when placing repeat orders. (Models and serial numbers are laser marked on clamps; For shim, same models and serial numbers as clamps may be specified.)

■ indicates made to order.

Model		CPH-□03H	CPH-□06H	CPH-□10H	CPH-□16H	CPH-□25H	CPH-□40H	
Clamping force*1	Hydraulic pressure 0MPa*2	kN	0.3	0.3	0.4	0.5	0.6	0.8
	Hydraulic pressure 5MPa	kN	2.9	4.4	7.3	11.6	18.0	28.8
	Hydraulic pressure 7MPa	kN	4.0	6.0	10.0	16.0	25.0	40.0
Clamping force calculation (P:Hydraulic pressure MPa)*1			$0.52 \times P + 0.3$	$0.81 \times P + 0.3$	$1.37 \times P + 0.4$	$2.21 \times P + 0.5$	$3.48 \times P + 0.6$	$5.60 \times P + 0.8$
Cylinder capacity*1	Unclamp	cm ³	1.7	2.8	4.8	9.9	16.0	27.2
	Clamp	cm ³	1.3	2.1	3.8	7.8	12.6	21.4
Full stroke		mm	4.4	4.4	5.0	6.5	7.0	7.5
Clamp stroke		mm	2.4	2.4	3.0	4.0	4.5	5.0
Safety stroke		mm	2.0	2.0	2.0	2.5	2.5	2.5
Lift stroke*3		mm	1					
Max. allowable eccentricity for pallet setting		mm	±1.0	±1.5	±2.0	±2.5	±3.5	±4.0
Lift force*1*4	Hydraulic pressure 3.5MPa	kN	1.1	1.9	3.0	4.9	7.5	12.0
	Hydraulic pressure 5MPa	kN	1.7	2.9	4.4	7.2	11.0	17.5
	Hydraulic pressure 7MPa	kN	2.4	4.2	6.4	10.2	15.5	24.8
Lift force calculation (P:Unclamping hydraulic pressure MPa)*1*4			$0.38 \times P - 0.24$	$0.63 \times P - 0.28$	$0.96 \times P - 0.37$	$1.52 \times P - 0.41$	$2.29 \times P - 0.50$	$3.63 \times P - 0.67$
Max. allowable load (including a pallet)*5	Horizontal mounting	kN	3.0	8.0	15.0	25.0	35.0	50.0
	Vertical mounting	kN	0.5	1.5	2.5	4.0	5.0	7.5
Mass*1		kg	0.3	0.6	0.8	1.6	2.7	4.9
Recommended tightening torque of mounting screws*6 N·m			7	7	12	29	57	100

- Pressure range : 5–7 MPa (model CPS-E), 2–7 MPa (model CPS-D, CPS-F) ● Proof pressure : 10.5 MPa
- Operating temperature : 0–70°C ● Fluid used : General mineral based hydraulic oil (ISO-VG32 equivalent)
- Recommended air blow pressure : 0.3–0.5 MPa

- *1: The figure indicates one piece of clamp. *2: The value indicates the force generated by the spring.
 *3: This is the amount for lifting pallet when unclamping.
 *4: Set the hydraulic pressure so that the lift force is equal to or greater than the max allowable load.
 *5: This is maximum allowable load of pallet, regardless of how many clamps are used. *6: ISO R898 class 12.9

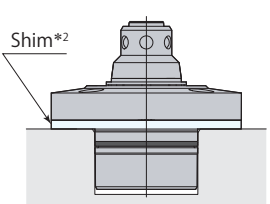
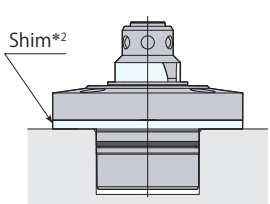
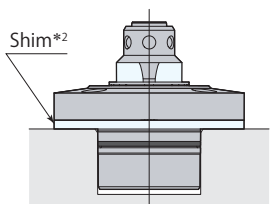
Pallet clamp type	A Taper cone circle	B *3 Taper cone cut 45°	C *3 Taper cone cut 90°
Hydraulic clamp model CPH *1	 model CPH-A□H	 model CPH-B□H	 model CPH-C□H

- *1: Hydraulic clamp model CPH and spring clamp model CPC (page →14) cannot be used together.
 *2: Shim of pallet clamp can be used when heights of mounted clamps vary. (option)
 *3: Taper cone cut can be selected from B type or C type.

Dimensions

Pallet clamp

CPH Hydraulic clamp

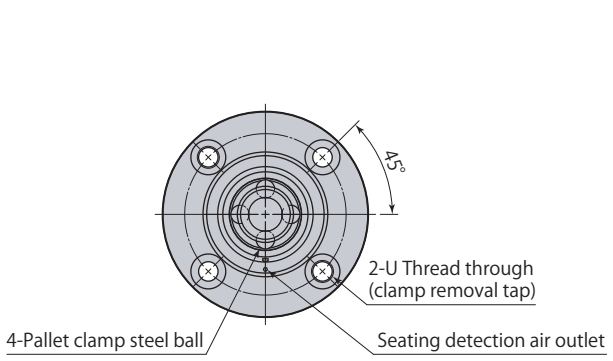

CPH-A03H

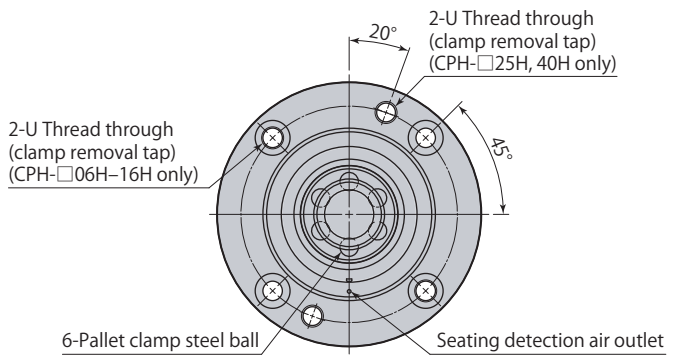

CPH-A06-40H

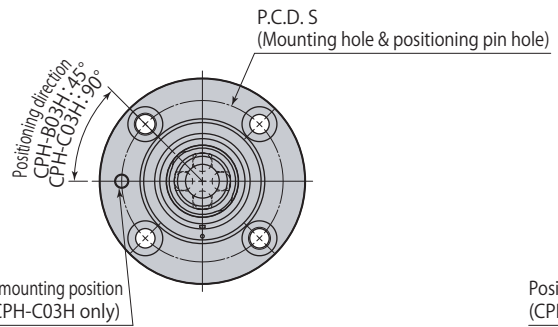

CPH-^B/_C 03H

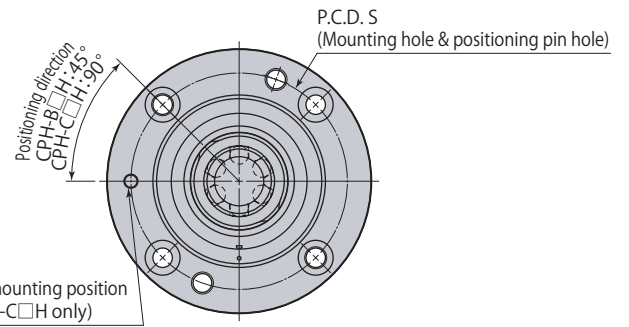

CPH-^B/_C 06-40H

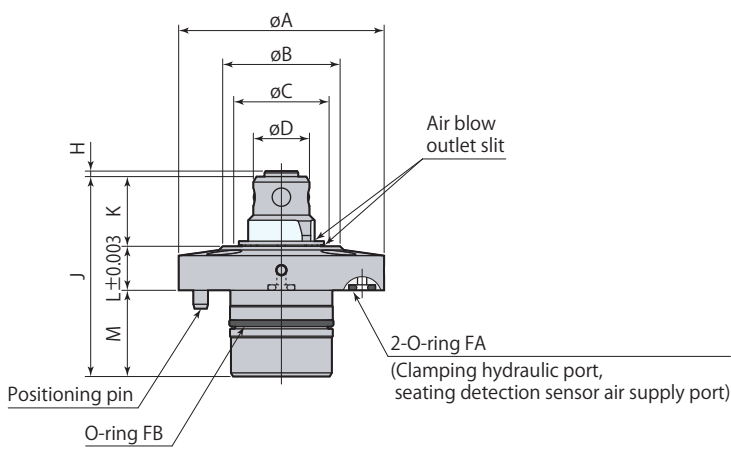

Unclamp

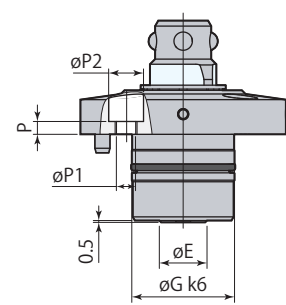

Stroke end

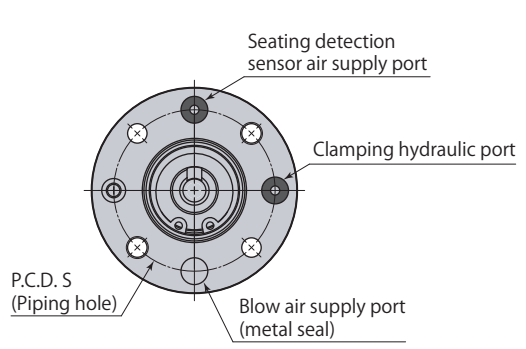

CPH-□03H

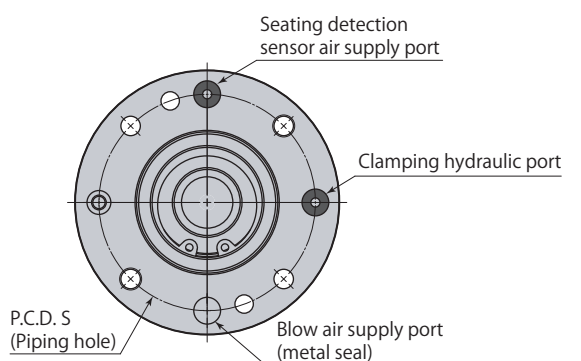

CPH-□06-40H

CPH-□□H	Pallet clamp Hydraulic clamp					7MPa	Double acting
----------------	-------------------------------------	--	--	--	--	-------------	----------------------

Model	CPH-□03H	CPH-□06H	CPH-□10H	CPH-□16H	CPH-□25H	CPH-□40H
øA	56	72	76	100	120	145
øB	32	45	48	66	78	94
øC	26	37	40	56	66	78
øD	15.3	19.3	23	29.4	37.3	46
øE	13	19	21	28	38	48
øG	28 ^{+0.015 +0.002}	39 ^{+0.018 +0.002}	45 ^{+0.018 +0.002}	54 ^{+0.021 +0.002}	65 ^{+0.021 +0.002}	80 ^{+0.021 +0.002}
H	1.5	1.5	1.3	1.3	1.3	1.3
J	54.5	61.5	67.5	79.5	93.5	109.5
K	19	22.5	26	34	41	48
L	12	13	15	18	22	28
M	23.5	26	26.5	27.5	30.5	33.5
P	3.5	5	6	6	7	9
øP1	5.3	5.3	6.8	9	11	14
øP2	9.5	9.5	11	14	17.5	20
S	44	59	62	84	100	122
U	M6×1	M6×1	M8×1.25	M10×1.5	M10×1.5	M12×1.75
O-ring FA (hardness Hs90)	P4	P4	P4	P6	P8	P10
O-ring FB (hardness Hs90)	AS568-022	AS568-028	AS568-030	AS568-135	AS568-141	AS568-150

- Be sure to match up phase of pallet clamp steel balls and locate ring steel ball grooves.
- Positioning direction is the direction in which tapered surface has not been cut.
- Use øA, which has been ground at the same time as tapered surface, for positioning measurement after mounting.
- Mounting screws are not included.
- Coupler (**pages →78–83**) recommended when using couplers in a set.
- dimensions are different from former pallet clamp (model CPH-□□F).

Pallet clamp

CPH Hydraulic clamp

Mounting details

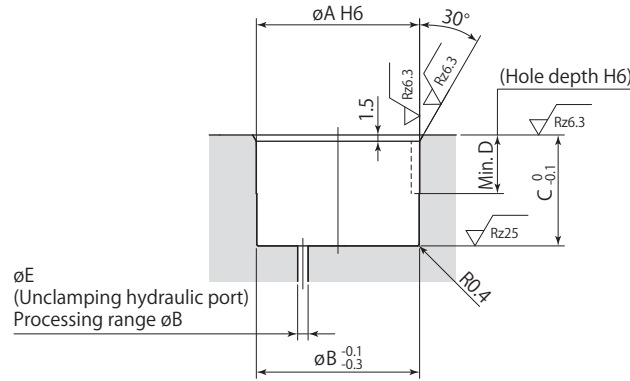
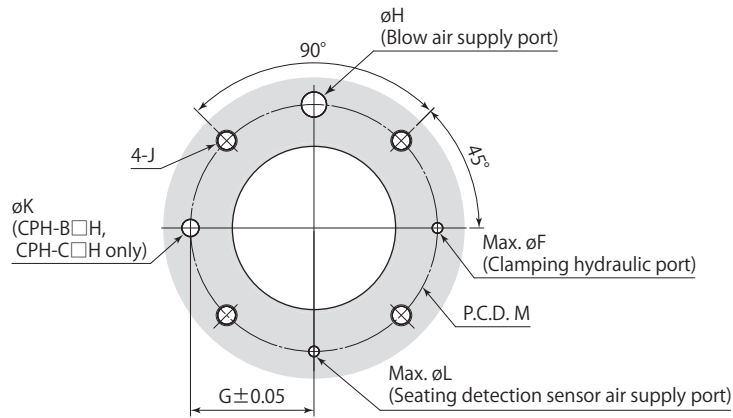

Rz: ISO4287(1997)

Shim (option)

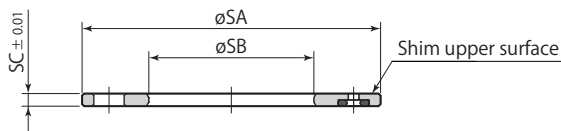
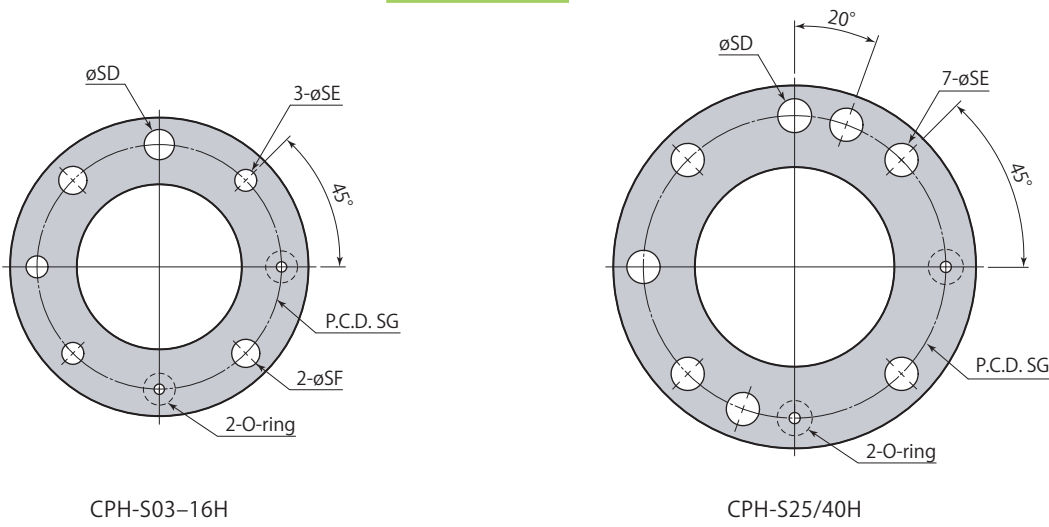

Pallet clamp
CPH Hydraulic clamp

CPH-□□H	Pallet clamp Hydraulic clamp	7MPa Double acting
----------------	-------------------------------------	---------------------------

mm

Model	CPH-□03H	CPH-□06H	CPH-□10H	CPH-□16H	CPH-□25H	CPH-□40H
øA	28 ^{+0.013} ₀	39 ^{+0.016} ₀	45 ^{+0.016} ₀	54 ^{+0.019} ₀	65 ^{+0.019} ₀	80 ^{+0.019} ₀
øB	28	39	45	54	65	80
øE	3-8	3-14	3-16	3-23	4-31	4-41
øF	2.5	2.5	2.5	4	6	8
G	22	29.5	31	42	50	61
øH	4.5-7	4.5-7	5.5-8	6-9	7-11	7-13
J	M5	M5	M6	M8	M10	M12
øL	2.5	2.5	2.5	4	6	8
M	44	59	62	84	100	122

Not using shim (standard specifications)

C	24	26.5	27	28	31	34
D	14	14	14	15	16	16
øK	4.1 ^{+0.1} ₀ depth 6	4.1 ^{+0.1} ₀ depth 6	4.1 ^{+0.1} ₀ depth 6	6.1 ^{+0.1} ₀ depth 6	6.1 ^{+0.1} ₀ depth 6	6.1 ^{+0.1} ₀ depth 6

Using shim (shim specifications)

C	21	23.5	24	25	27	30
D	11	11	11	12	12	12
øK	4.1 ^{+0.1} ₀ depth 4	4.1 ^{+0.1} ₀ depth 4	4.1 ^{+0.1} ₀ depth 4	6.1 ^{+0.1} ₀ depth 4	6.1 ^{+0.1} ₀ depth 4	6.1 ^{+0.1} ₀ depth 4

- Process with shim specification dimensions when shim is attached. Processing with standard specification dimensions will result in clamp damage during full stroke.
- Be sure to match up phase of pallet clamp steel balls and locate ring steel ball grooves.
- dimensions are different from former pallet clamp (model CPH-□□F).

mm

Shim	CPH-S03H	CPH-S06H	CPH-S10H	CPH-S16H	CPH-S25H	CPH-S40H
øSA	56	72	76	100	120	145
øSB	28.8	39.8	46	55	66	81
SC	3.05	3.05	3.05	3.05	4.05	4.05
øSD	7.3	7.3	8.2	9.2	11.2	13.2
øSE	5.3	5.3	6.3	9	11	14
øSF	6.8	6.8	9	11	-	-
SG	44	59	62	84	100	122
O-ring (hardness Hs90)	P4	P4	P4	P6	P8	P10
Mass	0.04 kg	0.06 kg	0.06 kg	0.12 kg	0.22 kg	0.32 kg

- This diagram indicates dimensions at shipping.
- Adjust thickness of shim by grinding to ensure flatness of pallet.
- Grind shim upper surface (surface without O-ring) to adjust shim.
- dimensions are different from former pallet clamp (model CPH-□□F).

Specifications

Type	Size	Mounting method
D : Repeatability 10 μm* ¹	03	T : Pallet upper surface mounting D : Pallet lower surface mounting F : Flange mounting
E : Repeatability 3 μm	06	
F : Seating surface positioning (Z axis positioning)	10	
S : Shim	16	
P : Protective plate* ²	25	
	40	

● Be sure to specify models and serial numbers when placing repeat orders. (Models and serial numbers are laser marked on clamps; For shim, same models and serial numbers as clamps may be specified.)

■ indicates made to order.

*1: model CPS-D (Repeatability 10 μm) is limited to sizes of 03, 06, 10, and 16.

*2: The protective plate is only flange mounting type.

Locate ring	D * ¹ Repeatability 10 μm	E * ¹ Repeatability 3 μm	F * ² Seating surface positioning (Z axis positioning)
T Pallet upper surface mounting	model CPS-D□T 	model CPS-E□T 	model CPS-F□T
D Pallet lower surface mounting	model CPS-D□D 	model CPS-E□D 	model CPS-F□D
F Flange mounting	model CPS-D□F 	model CPS-E□F 	model CPS-F□F

*1: model CPS-D (Repeatability 10 μm) and model CPS-E (Repeatability 3 μm) of locate ring cannot be used together.

*2: model CPS-F (Seating surface positioning) needs the positioning of XY axes.

*3: It is recommended to use a shim (option) to adjust mounting hole depth for the locate rings for pallet upper surface mounting and lower surface mounting. Grind shim to adjust thickness.

*4: Protective plate (flange mounting only) can be used to prevent damage of seating surface, when pallet must be placed on the floor, etc. (option)

*5: Shim of locate ring of flange mounting can be used when heights of mounted locate rings vary. (option)

Mass

kg

Locate ring	D Repeatability 10 μm	E Repeatability 3 μm	F Seating surface positioning (Z axis positioning)
T Pallet upper surface mounting	Model	CPS-D03T CPS-D06T CPS-D10T CPS-D16T	CPS-E03T CPS-E06T CPS-E10T CPS-E16T CPS-E25T CPS-E40T
	Mass	0.1 0.2 0.3 0.7	0.1 0.2 0.3 0.7 1.2 2
D Pallet lower surface mounting	Model	CPS-D03D CPS-D06D CPS-D10D CPS-D16D	CPS-E03D CPS-E06D CPS-E10D CPS-E16D CPS-E25D CPS-E40D
	Mass	0.2 0.3 0.5 1.2	0.2 0.3 0.5 1.2 2 3.1
F Flange mounting	Model	CPS-D03F CPS-D06F CPS-D10F CPS-D16F	CPS-E03F CPS-E06F CPS-E10F CPS-E16F CPS-E25F CPS-E40F
	Mass	0.1 0.2 0.3 0.8	0.1 0.2 0.3 0.8 1.5 2.5

Height of pallet from base plate

Locate ring mounting method	Pallet changing	Pallet setting (Unclamp)	Clamp
T Pallet upper surface mounting D Pallet lower surface mounting			
F Flange mounting			

		mm					
Spring clamp Hydraulic clamp		CPC CPH-□03H	CPC CPH-□06H	CPC CPH-□10H	CPC CPH-□16H	CPC CPH-□25H	CPC CPH-□40H
T Pallet upper surface mounting	A	Min. 33	Min. 38	Min. 44	Min. 55	Min. 66	Min. 79
	B	12.5	13.5	15.5	18.5	22.5	28.5
D Pallet lower surface mounting	C	11.5	12.5	14.5	17.5	21.5	27.5
	D	Min. 43	Min. 48	Min. 56	Min. 71	Min. 86	Min. 104
F Flange mounting	E	22	23.5	27.5	33.5	41	52
	F	21	22.5	26.5	32.5	40	51

- Pallet lift capacity for dimension A or D or more is needed to change pallet.
- The height from base plate to pallet varies when using shim for pallet clamp or locate ring (flange mounting).

Former type pallet clamps (model CPC-□□F, CPH-□□F) have different lift stroke, air blow (air outlet, sealing method, connecting pipe diameter), locate ring mounting dimensions. Please bear this in mind when placing repeat orders. Inquire separately regarding former type pallet clamps.

Dimensions

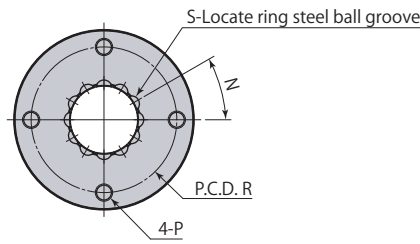

CPS-D03-16T Locate ring (D type)

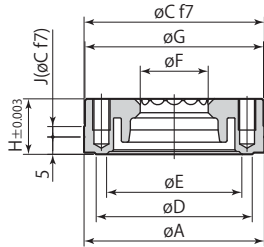

CPS-E03-40T Locate ring (E type)

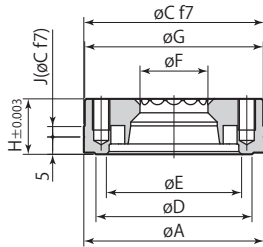

CPS-F03-40T Locate ring (F type)

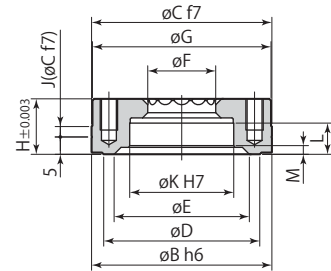

Model	CPS-□03T	CPS-□06T	CPS-□10T	CPS-□16T	CPS-□25T	CPS-□40T
∅A	40 ^{+0.005} _{-0.011}	52 ^{+0.006} _{-0.013}	60 ^{+0.006} _{-0.013}	80 ^{+0.006} _{-0.013}	95 ^{+0.007} _{-0.015}	115 ^{+0.007} _{-0.015}
∅B	40 ⁰ _{-0.016}	52 ⁰ _{-0.019}	60 ⁰ _{-0.019}	80 ⁰ _{-0.019}	95 ⁰ _{-0.022}	115 ⁰ _{-0.022}
∅C	40 ^{-0.025} _{-0.050}	52 ^{-0.030} _{-0.060}	60 ^{-0.030} _{-0.060}	80 ^{-0.030} _{-0.060}	95 ^{-0.036} _{-0.071}	115 ^{-0.036} _{-0.071}
∅D	32	45	48	66	78	94
∅E	28	39	42	58	68	80
∅F	15.6	19.6	23.3	29.7	37.6	46.3
∅G	39.5	51.5	59.5	79.5	94.5	114.5
H	13	16	20	25	30	35
J	3	3	3	3	3	4
∅K	22 ^{+0.021} ₀	30 ^{+0.021} ₀	32 ^{+0.025} ₀	45 ^{+0.025} ₀	55 ^{+0.030} ₀	65 ^{+0.030} ₀
L	7	9	11	14	16	19
M	2	2.5	2.5	3	4	5
N*	45°	30°	30°	30°	30°	30°
P	M5×0.8 depth 6	M5×0.8 depth 9	M6×1 depth 11	M8×1.25 depth 15	M10×1.5 depth 18	M12×1.75 depth 21
R	31	42	48	64	75	90
S	8	12	12	12	12	12

mm

* : Be sure to match up phase of locate ring steel ball grooves and pallet clamp steel balls.

● Mounting screws are not included.

Shim (option)

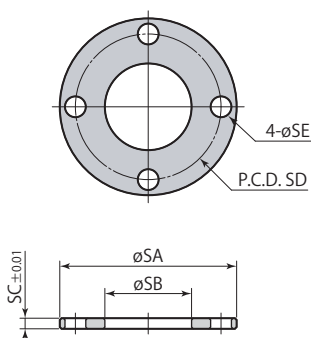

Shim	CPS-S03T	CPS-S06T	CPS-S10T	CPS-S16T	CPS-S25T	CPS-S40T
∅SA	39	51	59	79	94	114
∅SB	21	25	33	46	56	67
SC	2.05	3.05	3.05	3.05	4.05	4.05
SD	31	42	48	64	75	90
∅SE	6	6	7	9	11	14
Mass	0.01 kg	0.03 kg	0.04 kg	0.07 kg	0.13 kg	0.14 kg

mm

● This diagram indicates dimensions at shipping.

● Adjust thickness of shim by grinding to ensure flatness of pallet.

Mounting details

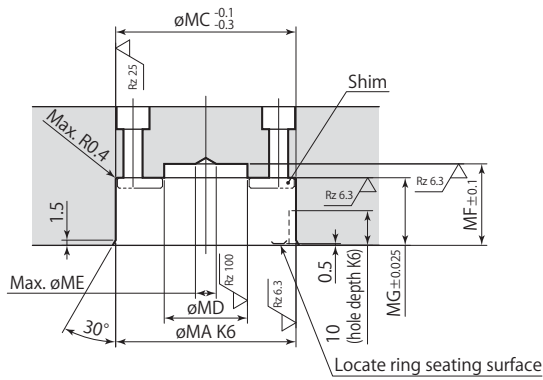
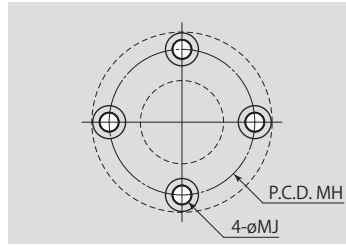

CPS-D03-16T, CPS-E03-40T

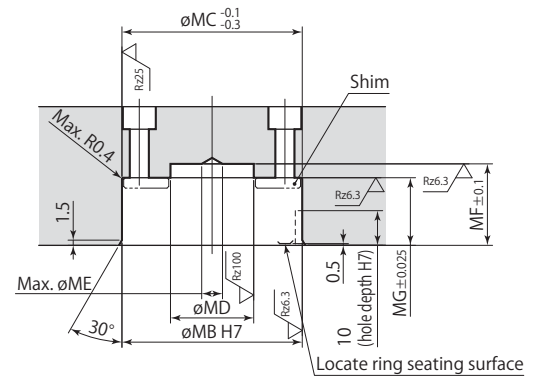

CPS-F03-40T

Rz: ISO4287(1997)

mm

Model	CPS-□03T	CPS-□06T	CPS-□10T	CPS-□16T	CPS-□25T	CPS-□40T
øMA	40 ^{+0.003} _{-0.013}	52 ^{+0.004} _{-0.015}	60 ^{+0.004} _{-0.015}	80 ^{+0.004} _{-0.015}	95 ^{+0.004} _{-0.018}	115 ^{+0.004} _{-0.018}
øMB	40 ^{+0.025} ₀	52 ^{+0.030} ₀	60 ^{+0.030} ₀	80 ^{+0.030} ₀	95 ^{+0.035} ₀	115 ^{+0.035} ₀
øMC	40	52	60	80	95	115
øMD	20	24	28	36	50	60
øME	6	6	8	10	12	15
MF	20	23.5	26.8	34.8	41.8	48.8
MG	15.5	19.5	23.5	28.5	34.5	39.5
MH	31	42	48	64	75	90
øMJ	5.5	5.5	6.6	9	11	13.5

- Be sure to match up phase of locate ring steel ball grooves and pallet clamp steel balls.
- dimensions are different from former pallet clamp (model CPC-□□F, CPH-□□F).

Dimensions

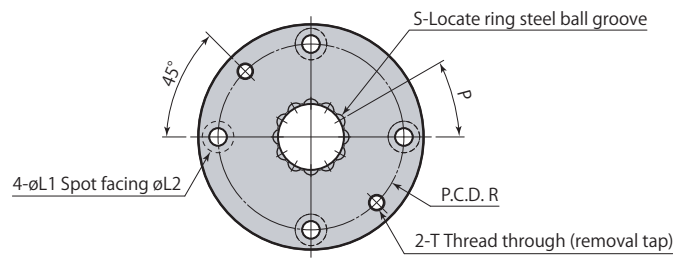

CPS-D03-16D Locate ring (D type)

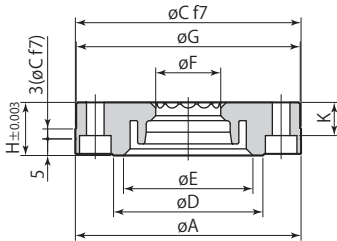

CPS-E03-40D Locate ring (E type)

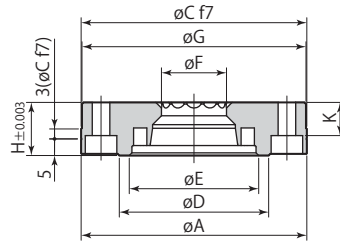

CPS-F03-40D Locate ring (F type)

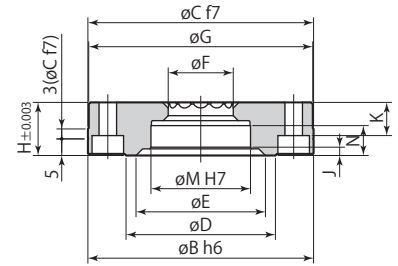

mm

Model	CPS-□03D	CPS-□06D	CPS-□10D	CPS-□16D	CPS-□25D	CPS-□40D
øA	55 ^{+0.006} _{-0.013}	68 ^{+0.006} _{-0.013}	75 ^{+0.006} _{-0.013}	100 ^{+0.007} _{-0.015}	120 ^{+0.007} _{-0.015}	140 ^{+0.007} _{-0.018}
øB	55 ⁰ _{-0.019}	68 ⁰ _{-0.019}	75 ⁰ _{-0.019}	100 ⁰ _{-0.022}	120 ⁰ _{-0.022}	140 ⁰ _{-0.025}
øC	55 ^{-0.030} _{-0.060}	68 ^{-0.030} _{-0.060}	75 ^{-0.030} _{-0.060}	100 ^{-0.036} _{-0.071}	120 ^{-0.036} _{-0.071}	140 ^{-0.043} _{-0.083}
øD	32	45	48	66	78	94
øE	28	39	42	58	68	80
øF	15.6	19.6	23.3	29.7	37.6	46.3
øG	54.5	67.5	74.5	99.5	119.5	139.5
H	13	16	20	25	30	35
J	2	2.5	2.5	3	4	5
K	7	10	13	16	19	22
øL1	5.3	5.3	6.8	9	11	14
øL2	9.5	9.5	11	14	17.5	20
øM	22 ^{+0.021} ₀	30 ^{+0.021} ₀	32 ^{+0.025} ₀	45 ^{+0.025} ₀	55 ^{+0.030} ₀	65 ^{+0.030} ₀
N	7	9	11	14	16	19
P*	45°	30°	30°	30°	30°	30°
R	43	56	61	82	98	116
S	8	12	12	12	12	12
T	M5×0.8	M5×0.8	M6×1	M8×1.25	M10×1.5	M12×1.75

* : Be sure to match up phase of locate ring steel ball grooves and pallet clamp steel balls.

● Mounting screws are not included.

Shim (option)

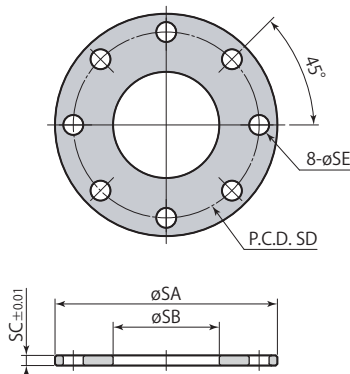

mm

Shim	CPS-S03D	CPS-S06D	CPS-S10D	CPS-S16D	CPS-S25D	CPS-S40D
øSA	54	67	74	99	119	139
øSB	24	32	39	55	65	77
SC	2.05	3.05	3.05	3.05	4.05	4.05
SD	43	56	61	82	98	116
øSE	6	6	7	9	11	14
Mass	0.06 kg	0.06 kg	0.07 kg	0.11 kg	0.22 kg	0.31 kg

● This diagram indicates dimensions at shipping.

● Adjust thickness of shim by grinding to ensure flatness of pallet.

Mounting details

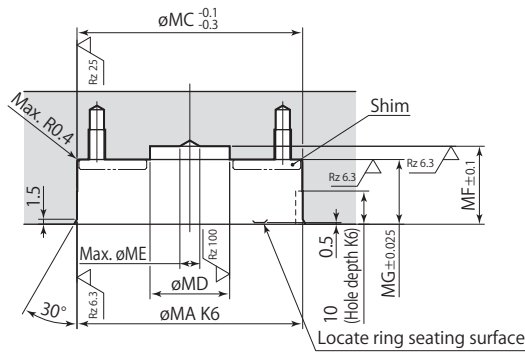
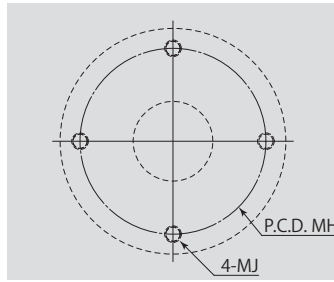

CPS-D03-16D, CPS-E03-40D

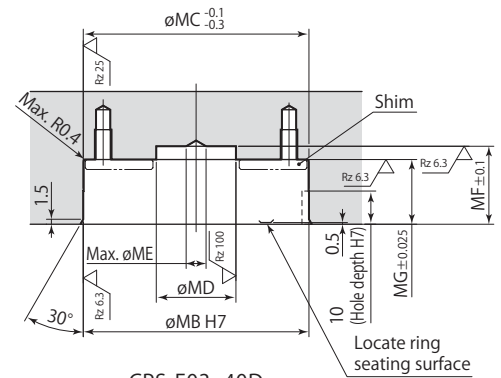

CPS-F03-40D

Rz: ISO4287(1997)

Model	CPS-□03D	CPS-□06D	CPS-□10D	CPS-□16D	CPS-□25D	CPS-□40D
øMA	55 ^{+0.004} _{-0.015}	68 ^{+0.004} _{-0.015}	75 ^{+0.004} _{-0.015}	100 ^{+0.004} _{-0.018}	120 ^{+0.004} _{-0.018}	140 ^{+0.004} _{-0.021}
øMB	55 ^{+0.030} ₀	68 ^{+0.030} ₀	75 ^{+0.030} ₀	100 ^{+0.035} ₀	120 ^{+0.035} ₀	140 ^{+0.035} ₀
øMC	55	68	75	100	120	140
øMD	20	24	28	36	50	60
øME	6	6	8	10	12	15
MF	20	23.5	26.8	34.8	41.8	48.8
MG	15.5	19.5	23.5	28.5	34.5	39.5
MH	43	56	61	82	98	116
MJ	M5	M5	M6	M8	M10	M12

- Be sure to match up phase of locate ring steel ball grooves and pallet clamp steel balls.
- dimensions are different from former pallet clamp (model CPC-□□F, CPH-□□F).

Dimensions

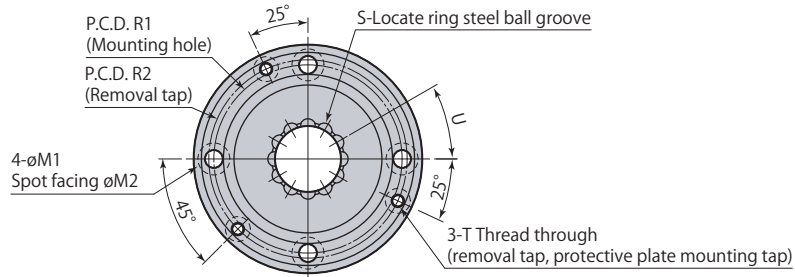

CPS-D03-16F Locate ring (D type)

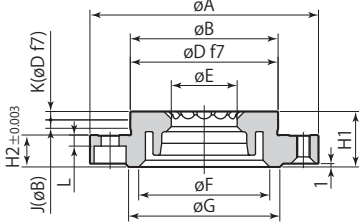

CPS-E03-40F Locate ring (E type)

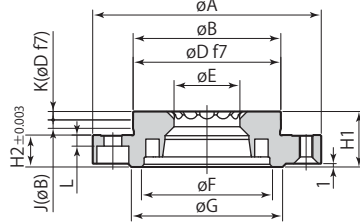

CPS-F03-40F Locate ring (F type)

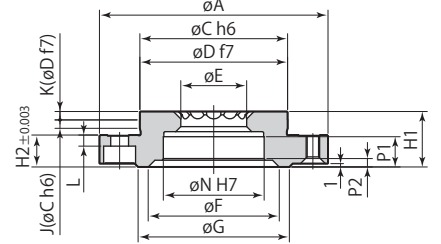

mm

Model	CPS-□03F	CPS-□06F	CPS-□10F	CPS-□16F	CPS-□25F	CPS-□40F
øA	55	68	75	100	120	140
øB	31 ^{+0.005} _{-0.011}	44 ^{+0.005} _{-0.011}	47 ^{+0.005} _{-0.011}	66 ^{+0.006} _{-0.013}	80 ^{+0.006} _{-0.013}	95 ^{+0.007} _{-0.015}
øC	31 ⁰ _{-0.016}	44 ⁰ _{-0.016}	47 ⁰ _{-0.016}	66 ⁰ _{-0.019}	80 ⁰ _{-0.019}	95 ⁰ _{-0.022}
øD	31 ^{-0.025} _{-0.050}	44 ^{-0.025} _{-0.050}	47 ^{-0.025} _{-0.050}	66 ^{-0.030} _{-0.060}	80 ^{-0.030} _{-0.060}	95 ^{-0.036} _{-0.071}
øE	15.6	19.6	23.3	29.7	37.6	46.3
øF	28	39	42	58	68	80
øG	32	45	48	66	78	94
H1	15.5	16.5	20	25	30	35
H2	9	9.5	11.5	14.5	18	23
J	2.4	2.5	3.2	4.7	4.2	4.2
K	2.1	2.5	2.8	3.3	3.8	3.8
L	2.8	3.3	4.2	5.2	6.5	9.5
øM1	5.3	5.3	6.8	9	11	14
øM2	9.5	9.5	11	14	17.5	20
øN	22 ^{+0.021} ₀	30 ^{+0.021} ₀	32 ^{+0.025} ₀	45 ^{+0.025} ₀	55 ^{+0.030} ₀	65 ^{+0.030} ₀
P1	7	9	11	14	16	19
P2	2	2.5	2.5	3	4	5
R1	43	56	61	82	98	116
R2	46	59	64	88	106	124
S	8	12	12	12	12	12
T	M4×0.7	M4×0.7	M5×0.8	M5×0.8	M6×1	M6×1
U*	45°	30°	30°	30°	30°	30°

* : Be sure to match up phase of locate ring steel ball grooves and pallet clamp steel balls.

● Mounting screws are not included.

Shim (option)

mm

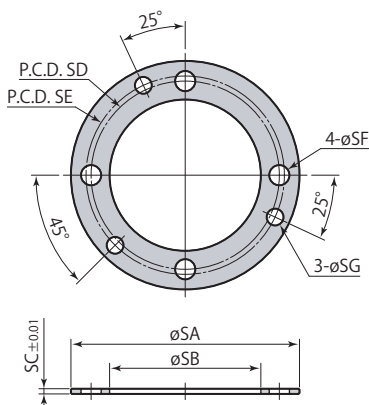

Shim	CPS-S03F	CPS-S06F	CPS-S10F	CPS-S16F	CPS-S25F	CPS-S40F
øSA	55	68	75	100	120	140
øSB	32	45	48	67	81	96
SC	1.55	1.55	2.05	3.05	3.05	3.05
SD	43	56	61	82	98	116
SE	46	59	64	88	106	124
øSF	6	6	7	9	11	14
øSG	5	5	6	6	7	7
Mass	0.02 kg	0.02 kg	0.04 kg	0.09 kg	0.13 kg	0.17 kg

● This diagram indicates dimensions at shipping.

● Adjust thickness of shim by grinding to ensure flatness of pallet.

Mounting details

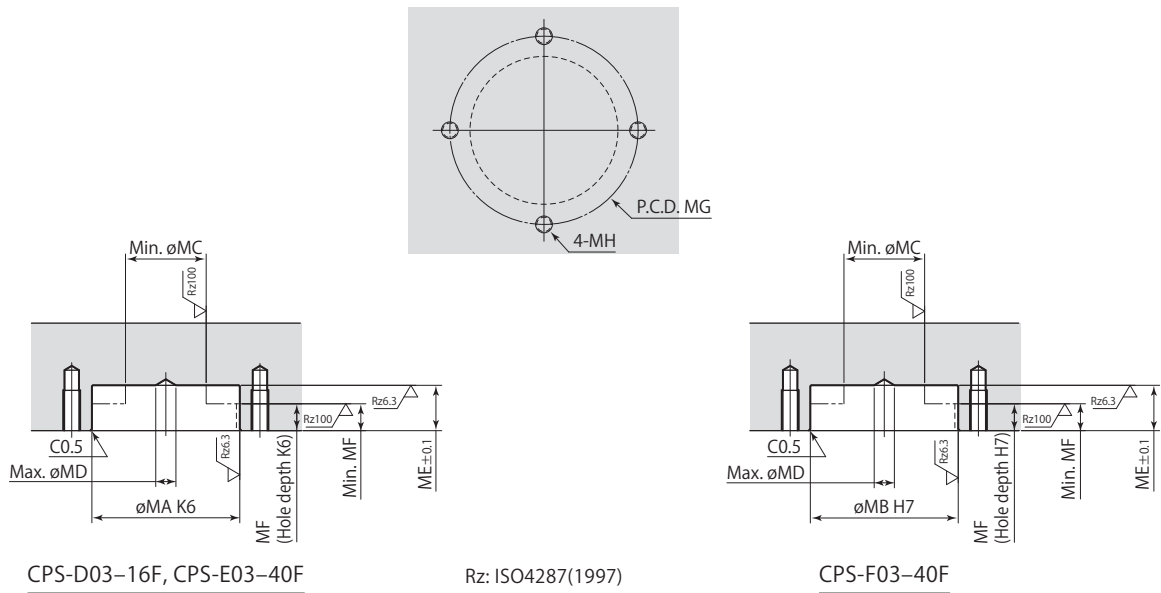

CPS-D03-16F, CPS-E03-40F

Rz: ISO4287(1997)

CPS-F03-40F

Model	CPS-□03F	CPS-□06F	CPS-□10F	CPS-□16F	CPS-□25F	CPS-□40F
øMA	31 ^{+0.003} _{-0.013}	44 ^{+0.003} _{-0.013}	47 ^{+0.003} _{-0.013}	66 ^{+0.004} _{-0.015}	80 ^{+0.004} _{-0.015}	95 ^{+0.004} _{-0.018}
øMB	31 ^{+0.025} ₀	44 ^{+0.025} ₀	47 ^{+0.025} ₀	66 ^{+0.030} ₀	80 ^{+0.030} ₀	95 ^{+0.035} ₀
øMC	20	24	28	36	50	60
øMD	6	6	8	10	12	15
MG	43	56	61	82	98	116
MH	M5	M5	M6	M8	M10	M12

Not using shim (standard specifications)

ME	10.5	13.5	14.8	19.8	23.3	25.3
MF	7.5	8	9.5	11.5	13	13

Using shim (shim specifications)

ME	9	12	12.8	16.8	20.3	22.3
MF	6.5	6.5	7.5	8.5	10	10

- Be sure to match up phase of locate ring steel ball grooves and pallet clamp steel balls.
- dimensions are different from former pallet clamp (model CPC-□□F, CPH-□□F).

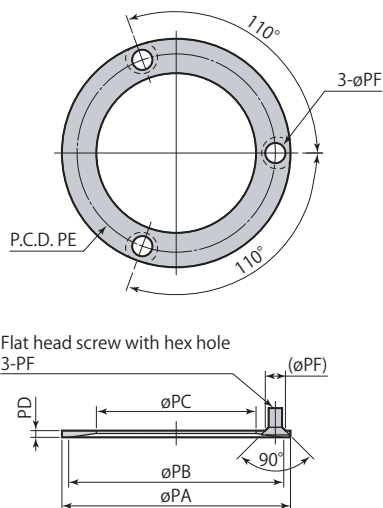

Protective plate (option)

Protective plate	CPS-P03F	CPS-P06F	CPS-P10F	CPS-P16F	CPS-P25F	CPS-P40F
øPA	55	68	75	100	120	140
øPB	51	64	68	94	114	132
øPC	34.5	47.5	50.5	68.5	80.5	96.5
PD	2	2	2	2.5	3	3
PE	46	59	64	88	106	124
øPF	6	6	8	8	9	9
Mass	0.02 kg	0.02 kg	0.03 kg	0.06 kg	0.1 kg	0.13 kg

Pitch tolerance of Pal system

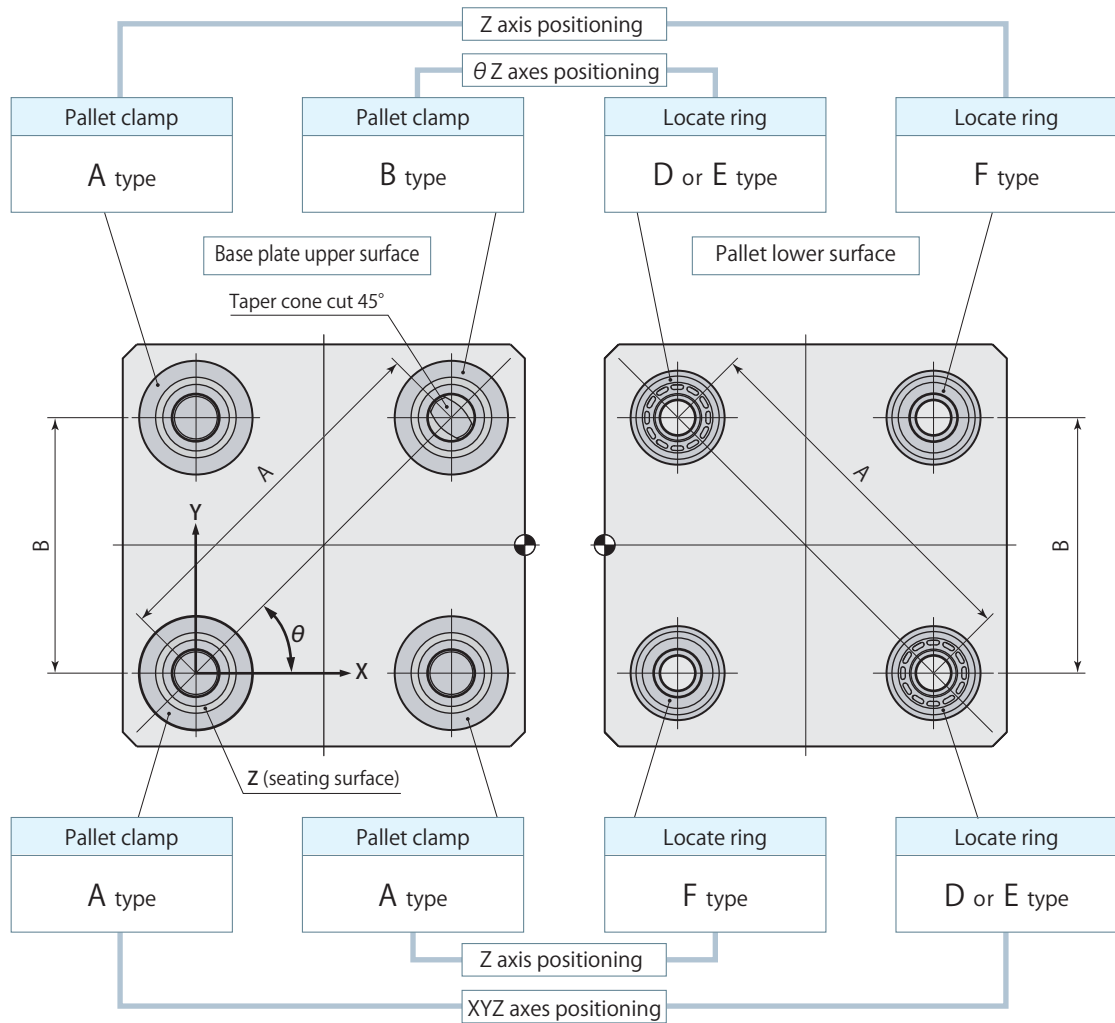

Model (Size)	03	06	10	16	25	40
Pitch tolerance of A dimensions		±0.01		±0.02		±0.03
Pitch tolerance of B dimensions		±0.03		±0.04		±0.05

Method for positioning pallet changer setup table

Internal hole of model CPS-F (Seating surface positioning) can be used for positioning of setup table for pallet change with pallet changer. In order to sustain accuracy, do not allow surfaces other than those of pallet clamp model CPC or model CPH to come into contact with tapered surface or seating surface.

Locate ring XYZ axes and θ Z axes positioning

Locate ring Z axis positioning

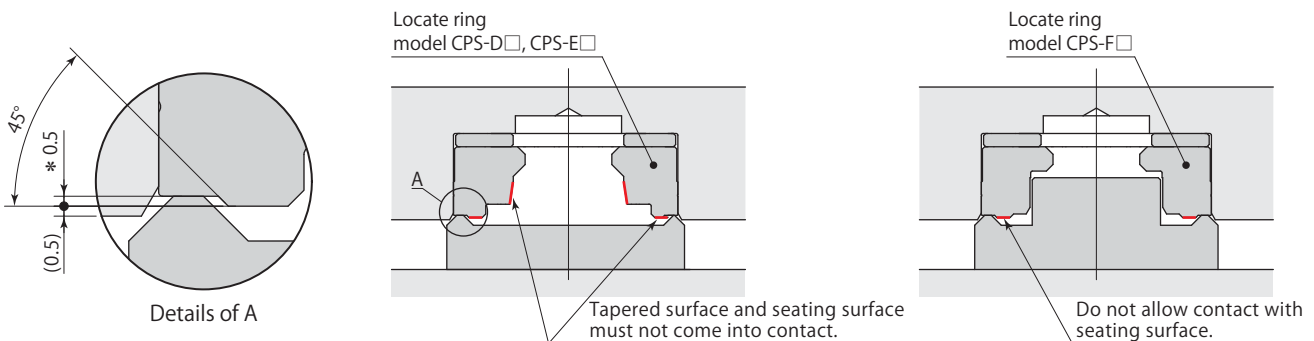

* : 1mm for CPS-□□F (Locate ring for flange mounting)

Pallet clamp

CP□

Pallet change

- When pallet changing, the pallet should be mounted or dismounted observing the figures shown in "Max. allowable eccentricity for pallet setting". (Refer to **page →15** (model CPC), **page →21** (model CPH) for max. allowable eccentricity for pallet setting.)
- Ensure that pallet does not lean to the side when pallet mounting or dismounting. When dismounting pallet in particular, pulling while in a tilted condition can damage pallet clamp and locate ring. A guide pin is recommended to prevent the pallet from leaning.

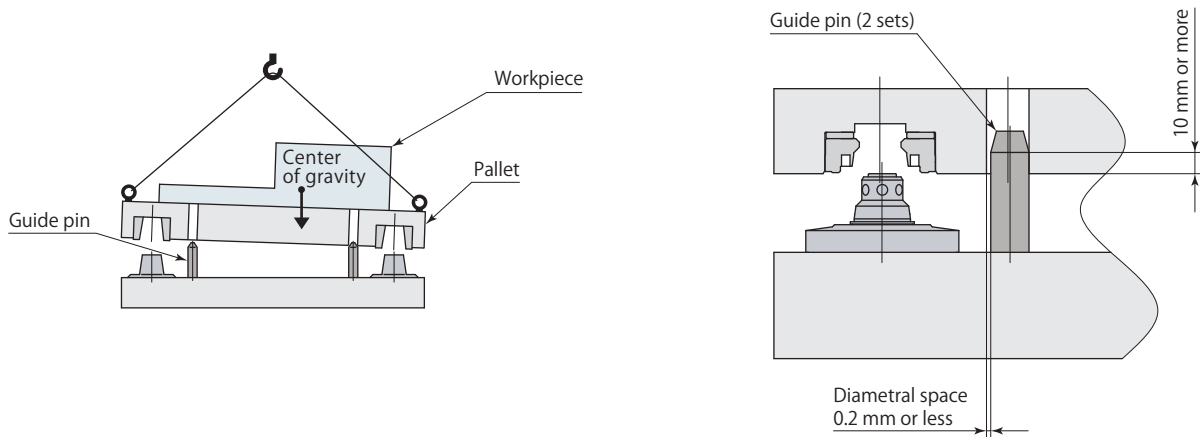

For vertical mounting of pallet

- A guide pin must be installed when mounting pallet vertically.
- Ensure spacing is set in order to ensure that mounted guide pin does not affect positioning.
- Ensure the pallet is closely contact with the base when it is clamped. Clamping with a space may cause the damage of both of clamp and locate ring.
(Refer to **page →27** for the height of pallet from base plate when pallet setting.)

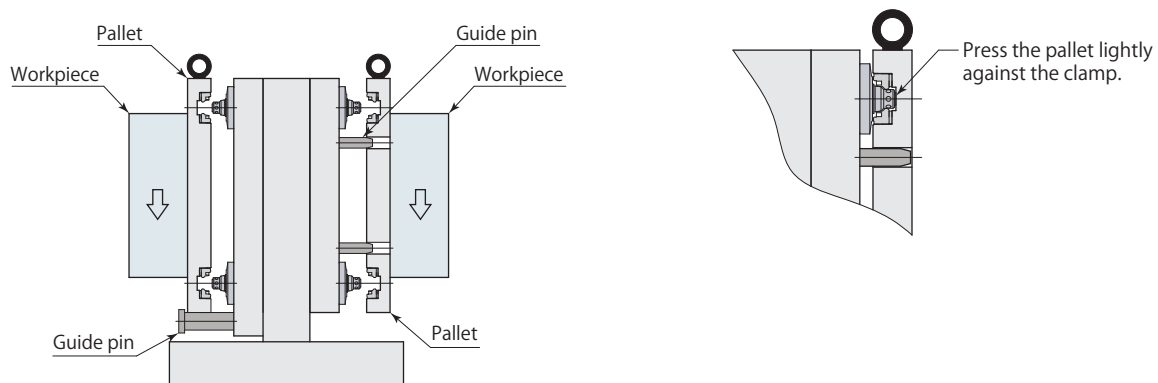

Level adjustment

Level adjustment of pallet clamp seating surface

- If level adjustment of pallet clamp seating surface is required, use pallet clamp shim (option). The level can be adjusted by grinding the shim.
- Grind shim upper surface (surface without O-ring).
- The measurement on the seating surface should be performed under the pallet clamped condition without locate rings. (Recommended adjustment figure : $\pm 0.003\text{mm}$)

Level adjustment of locate ring seating surface

- If level adjustment of locate ring seating surface is required, use locate ring shim (option). The level can be adjusted by grinding the shim. (Recommended adjustment figure : $\pm 0.003\text{mm}$)

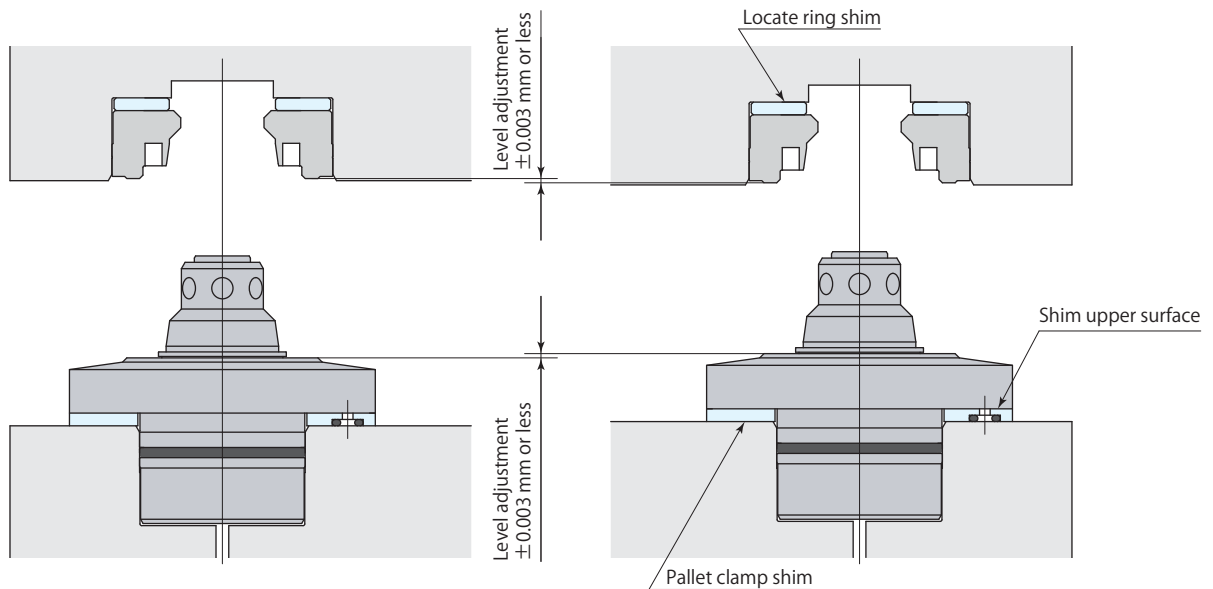

Mounting & dismounting of clamp

Mounting of clamp

- ① The ring has been mounted on the clamp to avoid taking it apart during the shipment. Remove it after mounting the clamp on the base plate, supplying the hydraulic pressure for unclamping.
- ② The ring is an important part for dismounting the clamp. Store it for future maintenance.

Dismounting of clamp

- ① Mount the ring before dismounting the clamp from the base plate. Supply hydraulic pressure for unclamping to mount it.
- ② Drain oil in the circuit and remove the mounting screws.
- ③ Mount the set-screws on the mounting tap to protect the threads and clamp mounting surface.
- ④ Mount the clamp removal screw on the clamp removal tap and dismount the clamp.
- ⑤ Retain the clamp upright condition when dismounting it.

Mounting of clamp

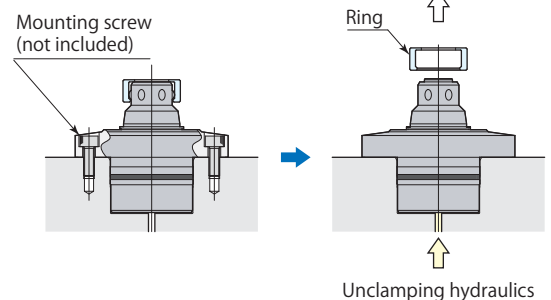

Dismounting of clamp

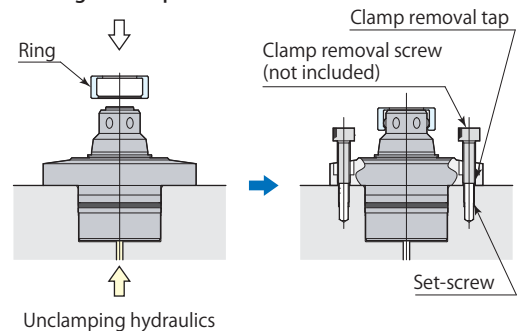

Air sensor recommended condition of use

Supplier and model	ISA3-F/G series manufactured by SMC
	GPS2-05, GPS3-E series manufactured by CKD
Air supply pressure	0.2 MPa
Inner diameter of piping	ø4 mm
Overall piping length	5 m or less

- Supply the dry and filtered air. Particulate size $5\ \mu\text{m}$ or less is recommended.
- Use a solenoid valve with needle for air sensor unit and control it supplying air all the time in order to eliminate intrusion of chips or coolant.

- There is a case that air sensing cannot be made successfully as designed when it is used out of the usage shown on the left. Contact Technical service center for more details.
- Refer to the sensor supplier's instruction manual for the details of setting.
- Sensing performance such as detectable time and pressure differs depending on the supplier and model number of the sensor. Select the right model referring to sensor's application and characteristics.
- Clamp state observation or operating check by the air sensor should be made while air blow is OFF.

Hydraulic and pneumatic circuit diagram

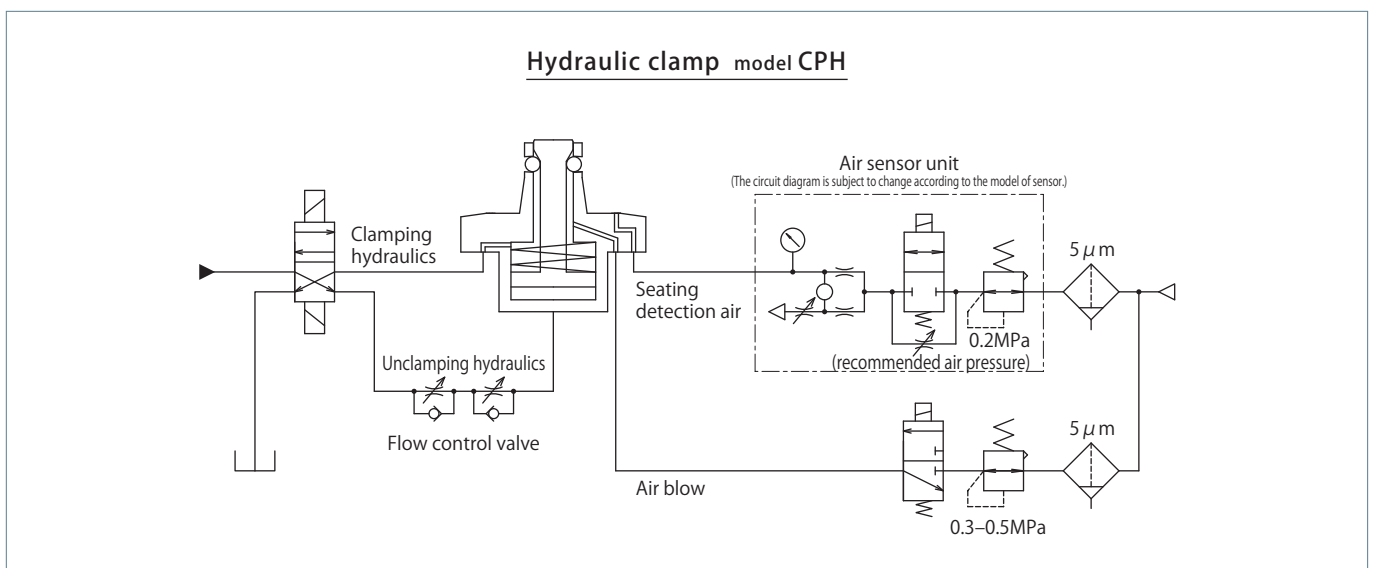
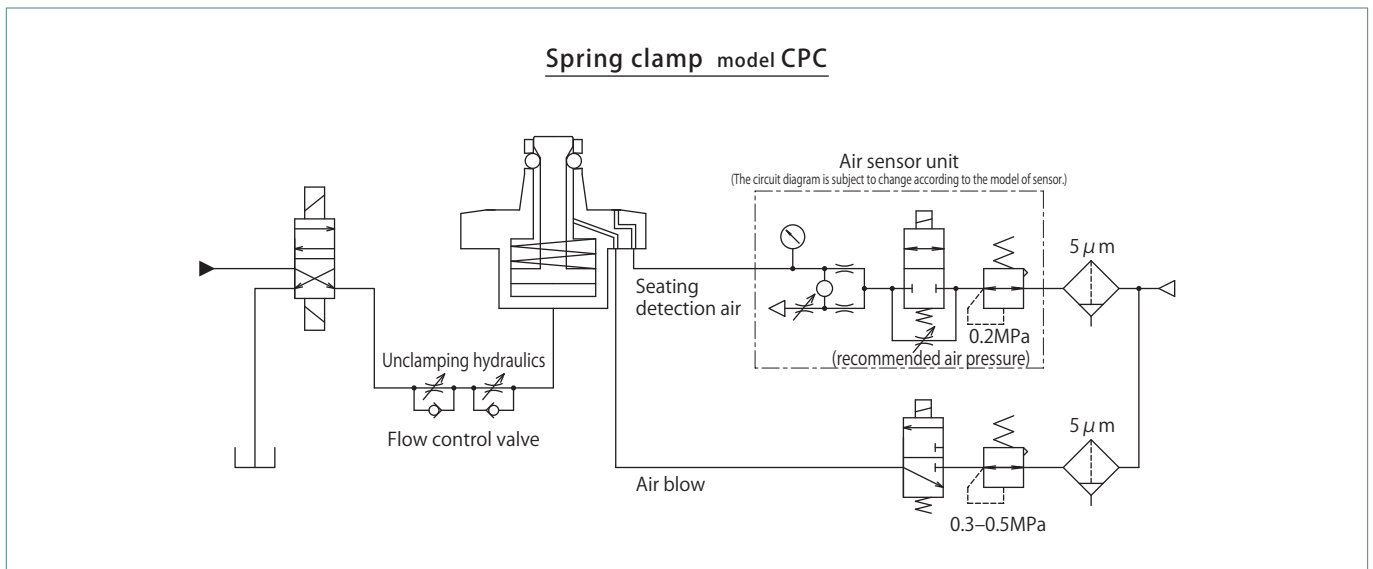

- Be sure to make inner diameter of air blow circuit 8 mm or more except for clamp mounting surface.
- Adjust full stroking time to be more than 1 second by a flow control valve to avoid impact at the time of clamp or unclamp action.

air Pallet clamp

Dual cylinder model Double acting 0.5 MPa

model **CPY**

Locate ring
Flange mounting
model **CPS-EF**



Air pallet clamp Dual cylinder model
model **CPY-A**

Dual cylinder model

model **CPY-□□H** PAT.



Highly rigid pallet clamp and repeatability of 3 μm with dual surface contact
 Compact downsized compared with the conventional model thanks to dual cylinder structure

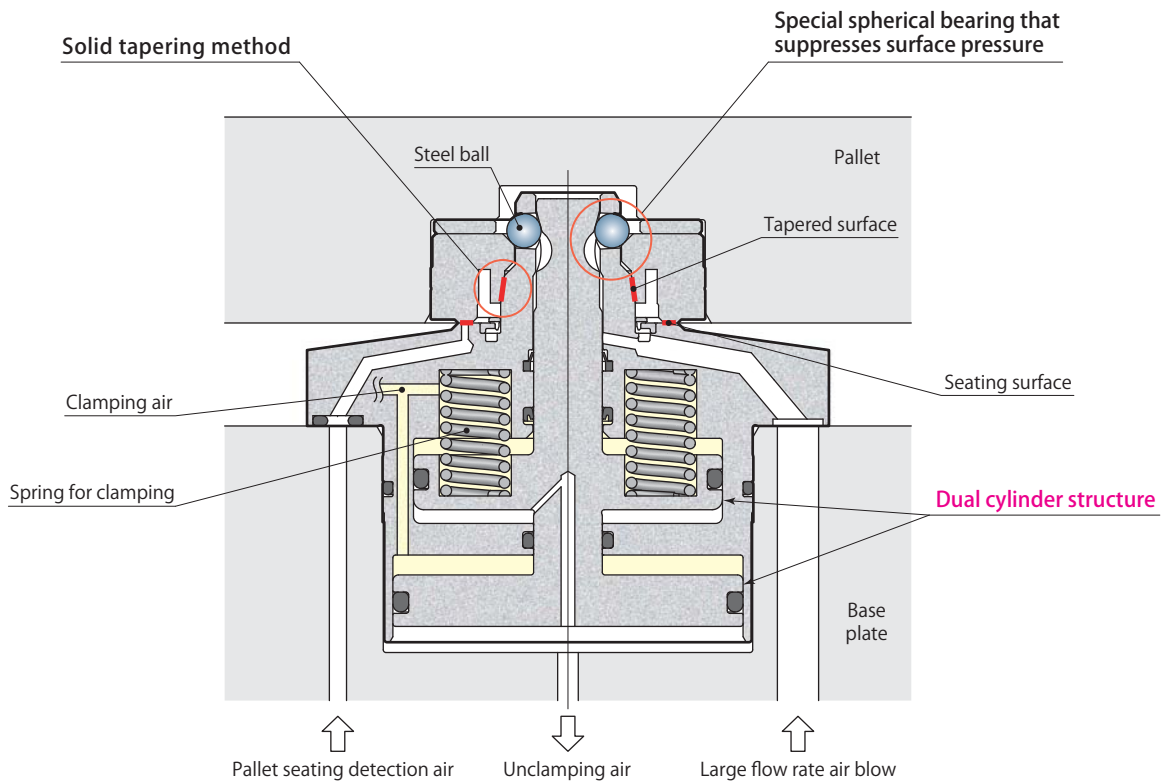

- Specifications page → 41
- Dimensions page → 42
- Mounting details page → 49
- Locate ring page → 46

Air pallet clamp
Dual cylinder model

Specifications

	Type	Size	
CPY -	A : Taper cone circle	02	H
	B : Taper cone cut 45°	03	
	C : Taper cone cut 90°	04	
		06	
	S : Shim	10	

■ indicates made to order.

Model			CPY-□02H	CPY-□03H	CPY-□04H	CPY-□06H	CPY-□10H
Air pressure range		MPa	0.4–0.5 (model CPS-L)		0.4–0.5 (model CPS-E)		
			0.25–0.5 (model CPS-D, CPS-F)				
Clamping force*1	Air pressure 0MPa*2	kN	0.1	0.3	0.8	1.2	1.8
	Air pressure 0.25MPa	kN	0.9	1.5	2.4	3.7	5.8
	Air pressure 0.3MPa	kN	1.0	1.8	2.7	4.2	6.6
	Air pressure 0.4MPa	kN	1.3	2.3	3.4	5.2	8.2
	Air pressure 0.5MPa	kN	1.7	2.7	4.0	6.1	9.8
Clamping force calculation (P: Air pressure MPa)*1			$3.10 \times P + 0.1$	$4.88 \times P + 0.3$	$6.38 \times P + 0.8$	$9.88 \times P + 1.2$	$16.0 \times P + 1.8$
Cylinder capacity*1	Clamp	cm ³	7.3	11.6	15.3	23.8	43.7
	Unclamp	cm ³	7.7	11.9	15.6	24.4	44.7
Full stroke		mm	4.4	4.4	4.4	4.4	5.0
Max. allowable eccentricity for pallet setting		mm	±1.0	±1.0	±1.0	±1.5	±2.0
Lift stroke*3		mm	1				
Lift force*1*4	Air pressure 0.25MPa	kN	0.3	0.4	0.2	0.5	0.8
	Air pressure 0.3MPa	kN	0.4	0.6	0.4	0.7	1.3
	Air pressure 0.4MPa	kN	0.6	0.8	0.7	1.3	2.2
	Air pressure 0.5MPa	kN	0.8	1.1	1.1	1.9	3.1
Lift force calculation (P: Unclamping air pressure MPa)*1*4			$1.74 \times P - 0.10$	$2.71 \times P - 0.25$	$3.55 \times P - 0.68$	$5.56 \times P - 0.92$	$8.94 \times P - 1.39$
Max. allowable load (including a pallet)*5	Horizontal mounting	kN	2.0	2.5	3.0	8.0	15.0
	Vertical mounting	kN	0.3	0.4	0.5	1.5	2.5
Mass*1		kg	0.4	0.6	0.8	1.3	2.3
Recommended tightening torque of mounting screws*6 N·m			3.5	3.5	7	7	7

- Proof pressure: 0.75 MPa
- Operating temperature: 0–70 °C
- Fluid used: Air*7
- Oil supply: Not required
- Recommended air blow pressure: 0.3–0.5 MPa

- *1: The figure indicates one piece of clamp.
- *2: The value indicates the force generated by the spring.
- *3: This is the amount for lifting pallet when unclamping.
- *4: Set the air pressure for unclamping so that the lift force is equal to or greater than the max. allowable load.
The max. allowable load can be calculated by the formula of lift force × quantity of CPY × 0.8.
- *5: This is maximum allowable load of pallet, regardless of how many clamps are used.
- *6: ISO R898 class 12.9
- *7: Supply the dry and filtered air. Particulate size 5 μm or less is recommended.

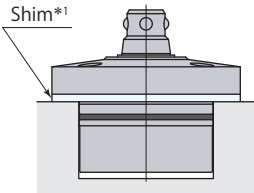
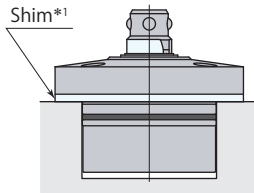
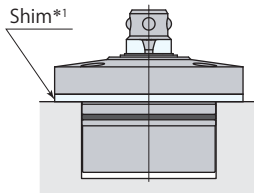
Pallet clamp type	A Taper cone circle	B *2 Taper cone cut 45°	C *2 Taper cone cut 90°
Air clamp model CPY	 model CPY-A□H	 model CPY-B□H	 model CPY-C□H

- *1: Shim of pallet clamp can be used when heights of mounted clamps vary. (option)
- *2: Taper cone cut can be selected from B type or C type.

Dimensions

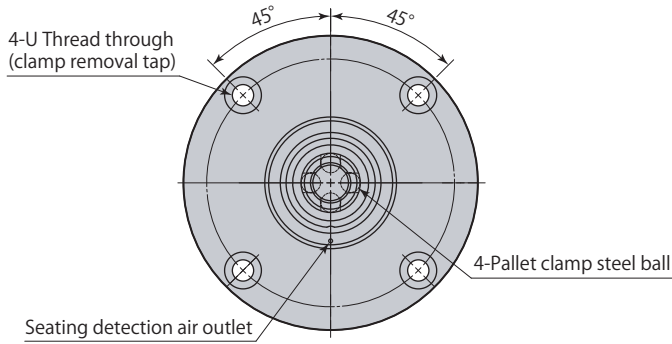

CPY-A02-04H

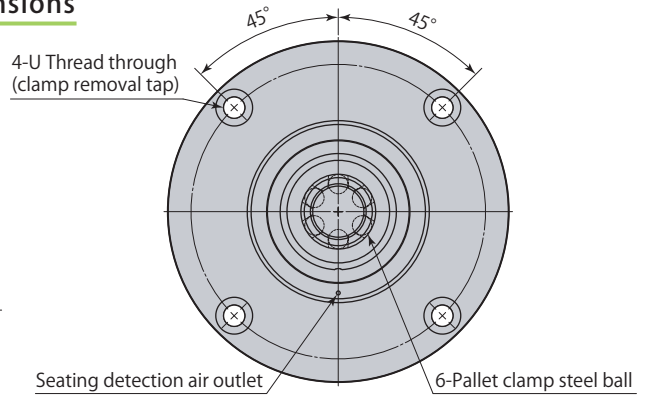

CPY-A06/10H

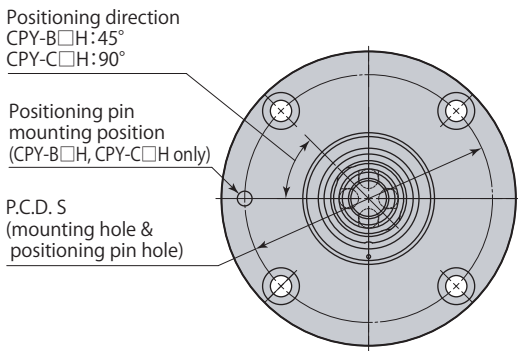

CPY-^B/_C 02-04H

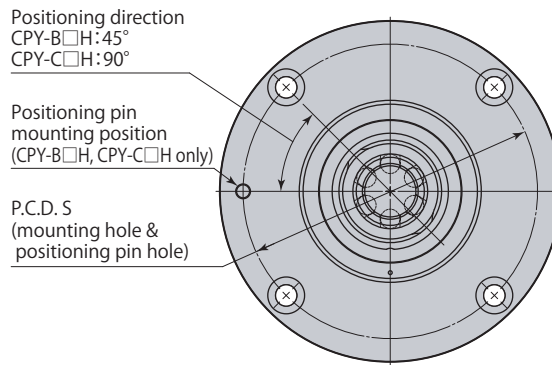

CPY-^B/_C 06/10H

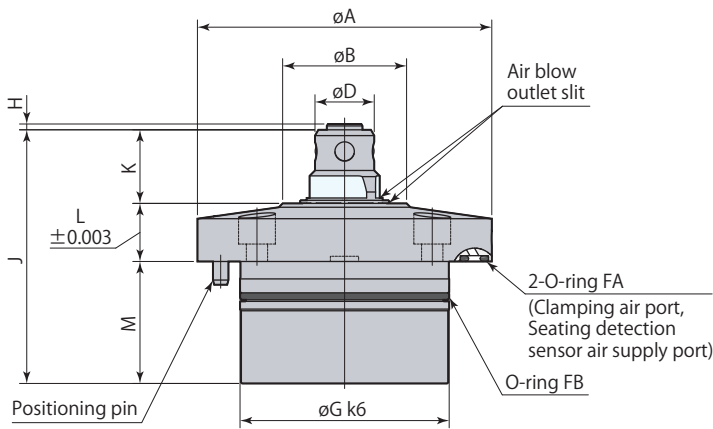

Unclamp

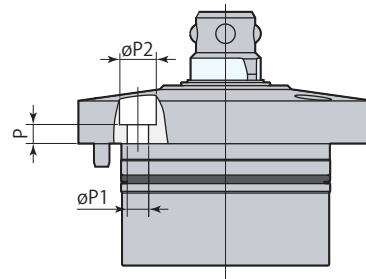

Stroke end

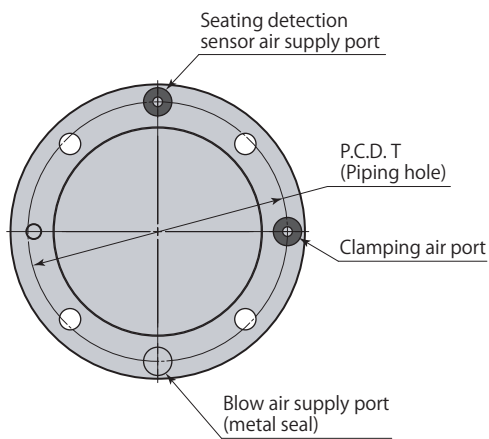

CPY-□02-04H

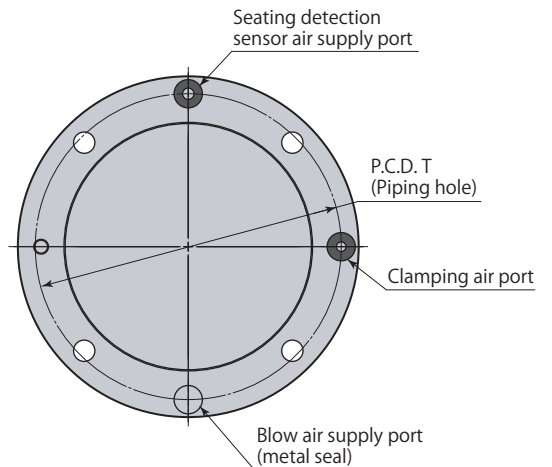

CPY-□06/10H

Model	CPY-□02H	CPY-□03H	CPY-□04H	CPY-□06H	CPY-□10H
øA	59	68	76	88	106
øB	32	32	32	45	48
øD	15.3	15.3	15.3	19.3	23
øG	39 ^{+0.018} _{+0.002}	48 ^{+0.018} _{+0.002}	54 ^{+0.021} _{+0.002}	66 ^{+0.021} _{+0.002}	84 ^{+0.025} _{+0.003}
H	1.5	1.5	1.5	1.5	1.3
J	61.5	61.5	65.5	72	83.5
K	19	19	19	22.5	26
L	12	12	15	18	22
M	30.5	30.5	31.5	31.5	35.5
P	4	3.5	5	8	11
øP1	4.3	4.3	5.5	5.5	5.5
øP2	8	8	9.5	9.5	9.5
S	49	58	64	76	94
T	50	59	67	79	96
U	M5×0.8	M5×0.8	M6×1	M6×1	M6×1
O-ring FA (fluorocarbon hardness Hs90)	P4	P4	P4	P4	P5
O-ring FB (fluorocarbon hardness Hs90)	AS568-028	AS568-031	AS568-033	AS568-036	AS568-151

- Be sure to match up phase of pallet clamp steel balls and locate ring steel ball grooves.
- Positioning direction is the direction in which tapered surface has not been cut.
- Use øA, which has been ground at the same time as tapered surface, for positioning measurement after mounting.
- Mounting screws are not included.
- Coupler (**pages →78–83**) recommended when using couplers in a set.
- Blow air supply port is metal seal. Air bubbles may come out from the mounting surface due to the air blow, however it is not abnormal.

Mounting details

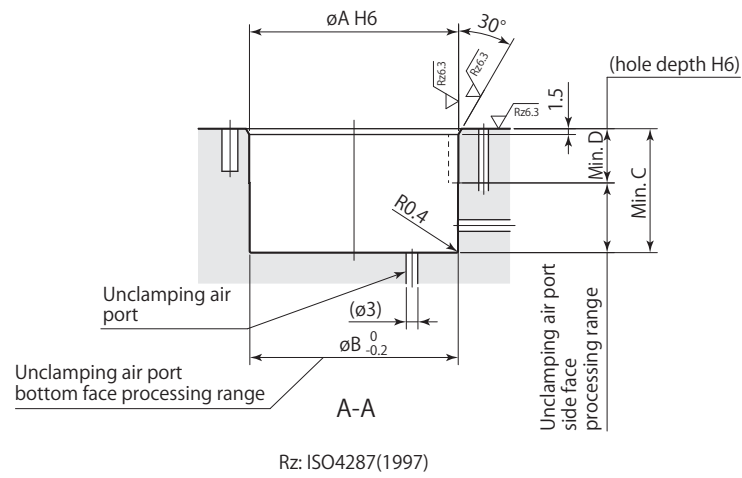
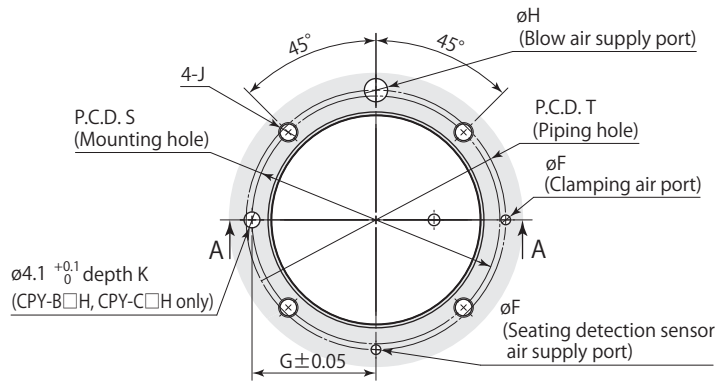

Shim (option)

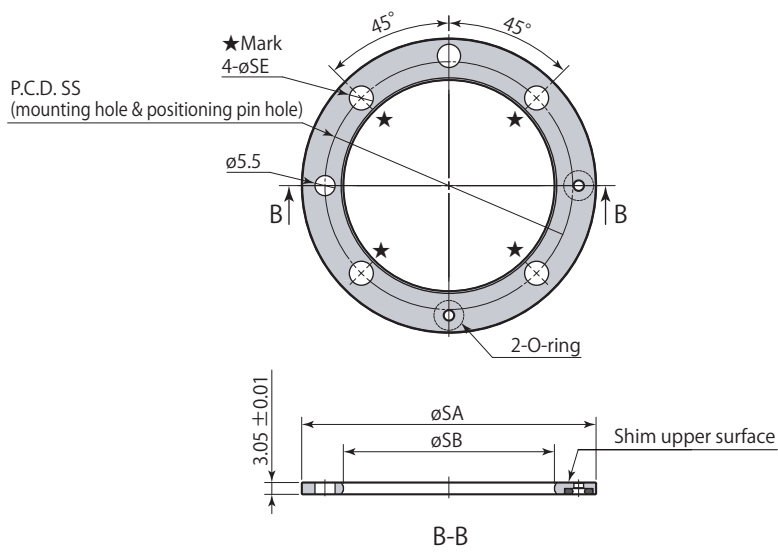

Air pallet clamp
Dual cylinder model

mm

Model	CPY-□02H	CPY-□03H	CPY-□04H	CPY-□06H	CPY-□10H
øA	39 ^{+0.016} ₀	48 ^{+0.016} ₀	54 ^{+0.019} ₀	66 ^{+0.019} ₀	84 ^{+0.022} ₀
øB	39	48	54	66	84
øF	2.5	2.5	2.5	2.5	3
G	24.5	29	32	38	47
øH	4.5-6	4.5-6	4.5-6	4.5-6	5.5-7
J	M4	M4	M5	M5	M5
S	49	58	64	76	94
T	50	59	67	79	96

Not using shim (standard specifications)

C	31	31	32	32	36
D	14	14	14	14	15
K	7	7	7	7	7

Using shim (shim specifications)

C	28	28	29	29	33
D	11	11	11	11	12
K	4	4	4	4	4

- Process with shim specification dimensions when shim is attached.
- Process either bottom or side surface of unclamping air port.
- Be sure to match up phase of pallet clamp steel balls and locate ring steel ball grooves.

mm

Shim	CPY-S02H	CPY-S03H	CPY-S04H	CPY-S06H	CPY-S10H
øSA	59	68	76	88	106
øSB	39.5	48.5	54.5	66.5	84.5
øSE	5.5	5.5	6.5	6.5	6.5
SS	49	58	64	76	94
O-ring (fluorocarbon hardness Hs90)	P4	P4	P4	P4	P5
Mass	0.03kg	0.04kg	0.05kg	0.06kg	0.07kg

- This diagram indicates dimensions at shipping.
- Adjust thickness of shim by grinding to ensure flatness of pallet.
- Grind shim upper surface (surface without O-ring) to adjust shim.





Specifications

Type	Size	Mounting method
D : Repeatability 10 μm	03 06 10	T : Pallet upper surface mounting
E : Repeatability 3 μm		D : Pallet lower surface mounting
L : Repeatability 3 μm* ¹		F : Flange mounting
F : Seating surface positioning (Z axis positioning)		
S : Shim		
P : Protective plate* ²		

■ indicates made to order.

*1: model CPS-L (Repeatability 3 μm) is available for size 03 only. (Exclusive use for CPY-□02H, CPY-□03H)

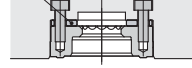
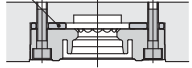
*2: The protective plate is only flange mounting type.

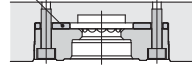
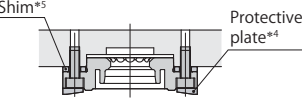
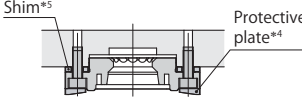
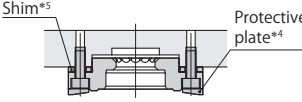
Locate ring	D * ¹ Repeatability 10 μm	E or L * ¹ Repeatability 3 μm	F * ² Seating surface positioning (Z axis positioning)
T Pallet upper surface mounting	model CPS-D□T 	model CPS-E□T 	model CPS-F□T 
D Pallet lower surface mounting	model CPS-D□D 	model CPS-E□D 	model CPS-F□D 
F Flange mounting	model CPS-D□F 	model CPS-E□F 	model CPS-F□F 

*1: model CPS-D (Repeatability 10 μm) cannot be used together with model CPS-E or CPS-L (repeatability 3 μm).

*2: model CPS-F (Seating surface positioning) needs the positioning of XY axes.

*3: It is recommended to use a shim (option) to adjust mounting hole depth for the locate rings for pallet upper surface mounting and lower surface mounting. Grind shim to adjust thickness.

*4: Protective plate (flange mounting only) can be used to prevent damage of seating surface, when pallet must be placed on the floor, etc. (option)

*5: Shim of locate ring of flange mounting can be used when heights of mounted locate rings vary. (option)

Locate ring model correspondence

Pallet clamp		CPY-□02H	CPY-□03H	CPY-□04H	CPY-□06H	CPY-□10H
Repeatability	3 μm	CPS-L03□		CPS-E03□	CPS-E06□	CPS-E10□
	10 μm	CPS-D03□			CPS-D06□	CPS-D10□
Seating surface positioning (Z axis positioning)		CPS-F03□			CPS-F06□	CPS-F10□

Mass

kg

Locate ring		D Repeatability 10 μm			E or L Repeatability 3 μm				F Seating surface positioning (Z axis positioning)		
T Pallet upper surface mounting	Model	CPS-D03T	CPS-D06T	CPS-D10T	CPS-L03T	CPS-E03T	CPS-E06T	CPS-E10T	CPS-F03T	CPS-F06T	CPS-F10T
	Mass	0.1	0.2	0.3	0.1	0.1	0.2	0.3	0.1	0.2	0.3
D Pallet lower surface mounting	Model	CPS-D03D	CPS-D06D	CPS-D10D	CPS-L03D	CPS-E03D	CPS-E06D	CPS-E10D	CPS-F03D	CPS-F06D	CPS-F10D
	Mass	0.2	0.3	0.5	0.2	0.2	0.3	0.5	0.2	0.3	0.5
F Flange mounting	Model	CPS-D03F	CPS-D06F	CPS-D10F	CPS-L03F	CPS-E03F	CPS-E06F	CPS-E10F	CPS-F03F	CPS-F06F	CPS-F10F
	Mass	0.1	0.2	0.3	0.1	0.1	0.2	0.3	0.1	0.2	0.4

Height of pallet from base plate

Locate ring mounting method	Pallet changing	Pallet setting (Unclamp)	Clamp
T Pallet upper surface mounting			
D Pallet lower surface mounting			
F Flange mounting			

mm

Pallet clamp		CPY-□02H	CPY-□03H	CPY-□04H	CPY-□06H	CPY-□10H
T Pallet upper surface mounting	A	Min. 33	Min. 33	Min. 36	Min. 43	Min. 51
	B	12.5	12.5	15.5	18.5	22.5
D Pallet lower surface mounting	C	11.5	11.5	14.5	17.5	21.5
	D	Min. 43	Min. 43	Min. 46	Min. 53	Min. 63
F Flange mounting	E	22	22	25	28.5	34.5
	F	21	21	24	27.5	33.5

- Pallet lift capacity for dimension A or D or more is needed to change pallet.
- The height from base plate to pallet varies when using shim for pallet clamp or locate ring (flange mounting).

Dimensions

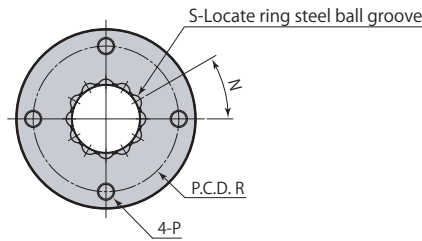

CPS-D03-10T Locate ring (D type)

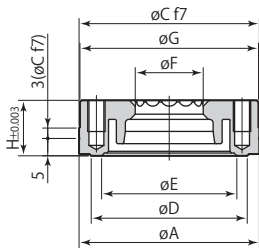

CPS-E03-10T Locate ring (E type)
CPS-L03T Locate ring (L type)

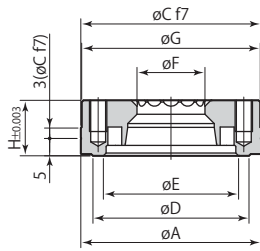

CPS-F03-10T Locate ring (F type)

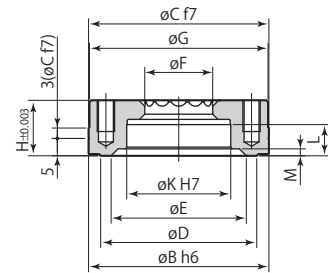

mm

Model	CPS-□03T	CPS-□06T	CPS-□10T
∅A	40 ^{+0.005} _{-0.011}	52 ^{+0.006} _{-0.013}	60 ^{+0.006} _{-0.013}
∅B	40 ⁰ _{-0.016}	52 ⁰ _{-0.019}	60 ⁰ _{-0.019}
∅C	40 ^{-0.025} _{-0.050}	52 ^{-0.030} _{-0.060}	60 ^{-0.030} _{-0.060}
∅D	32	45	48
∅E	28	39	42
∅F	15.6	19.6	23.3
∅G	39.5	51.5	59.5
H	13	16	20
∅K	22 ^{+0.021} ₀	30 ^{+0.021} ₀	32 ^{+0.025} ₀
L	7	9	11
M	2	2.5	2.5
N*	45°	30°	30°
P	M5×0.8 depth 6	M5×0.8 depth 9	M6×1 depth 11
R	31	42	48
S	8	12	12

* : Be sure to match up phase of locate ring steel ball grooves and pallet clamp steel balls.

● Mounting screws are not included.

Shim (option)

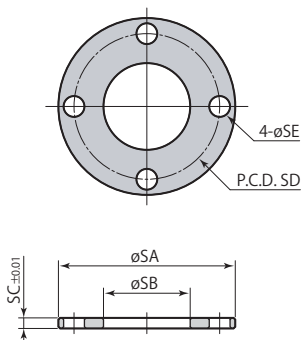

mm

Shim	CPS-S03T	CPS-S06T	CPS-S10T
∅SA	39	51	59
∅SB	21	25	33
SC	2.05	3.05	3.05
SD	31	42	48
∅SE	6	6	7
Mass	0.01 kg	0.03 kg	0.04 kg

● This diagram indicates dimensions at shipping.

● Adjust thickness of shim by grinding to ensure flatness of pallet.

Mounting details

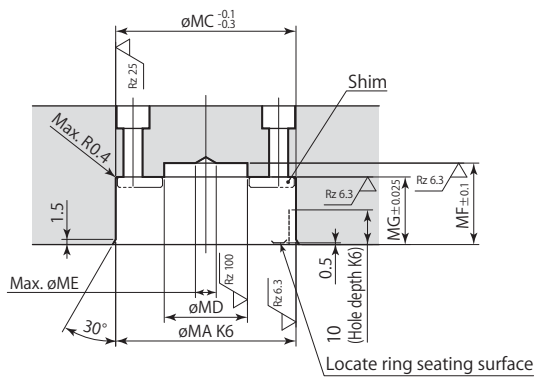
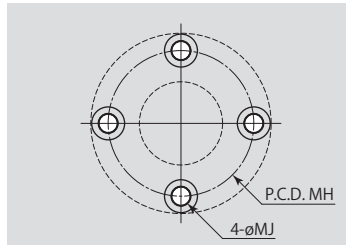

CPS-D03-10T, CPS-E03-10T, CPS-L03T

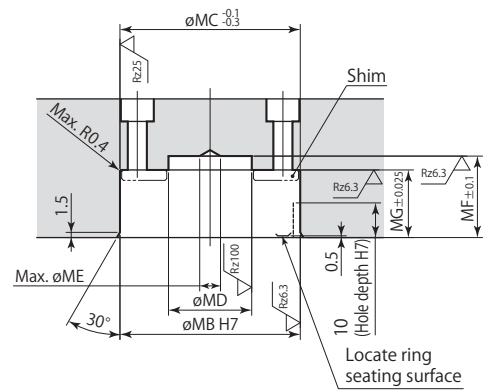

CPS-F03-10T

Rz: ISO4287(1997)

Model	CPS-□03T	CPS-□06T	CPS-□10T
φMA	40 ^{+0.003} _{-0.013}	52 ^{+0.004} _{-0.015}	60 ^{+0.004} _{-0.015}
φMB	40 ^{+0.025} ₀	52 ^{+0.030} ₀	60 ^{+0.030} ₀
φMC	40	52	60
φMD	20	24	28
φME	6	6	8
MF	20	23.5	26.8
MG	15.5	19.5	23.5
MH	31	42	48
φMJ	5.5	5.5	6.6

● Be sure to match up phase of locate ring steel ball grooves and pallet clamp steel balls.

Dimensions

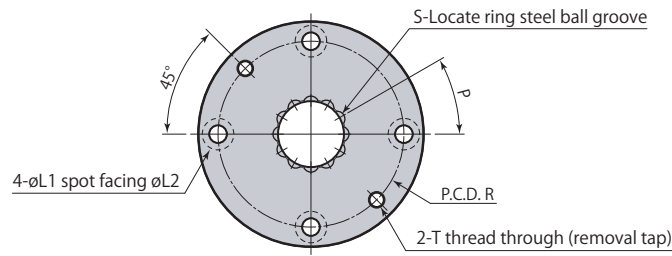

CPS-D03-10D Locate ring (D type)

CPS-E03-10D Locate ring (E type)
CPS-L03D Locate ring (L type)

CPS-F03-10D Locate ring (F type)

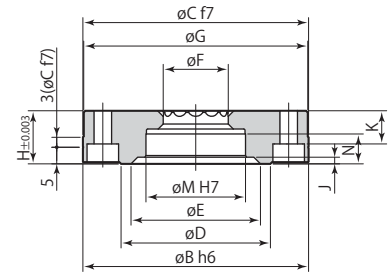
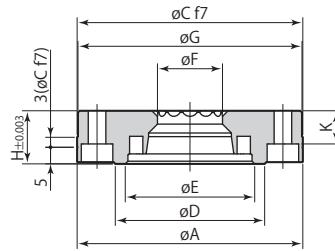
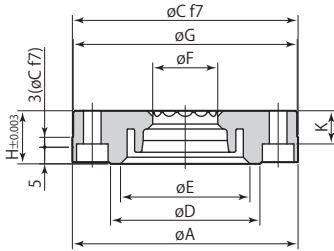

mm

Model	CPS-□03D	CPS-□06D	CPS-□10D
øA	55 ^{+0.006} _{-0.013}	68 ^{+0.006} _{-0.013}	75 ^{+0.006} _{-0.013}
øB	55 ⁰ _{-0.019}	68 ⁰ _{-0.019}	75 ⁰ _{-0.019}
øC	55 ^{-0.030} _{-0.060}	68 ^{-0.030} _{-0.060}	75 ^{-0.030} _{-0.060}
øD	32	45	48
øE	28	39	42
øF	15.6	19.6	23.3
øG	54.5	67.5	74.5
H	13	16	20
J	2	2.5	2.5
K	7	10	13
øL1	5.3	5.3	6.8
øL2	9.5	9.5	11
øM	22 ^{+0.021} ₀	30 ^{+0.021} ₀	32 ^{+0.025} ₀
N	7	9	11
P*	45°	30°	30°
R	43	56	61
S	8	12	12
T	M5×0.8	M5×0.8	M6×1

* : Be sure to match up phase of locate ring steel ball grooves and pallet clamp steel balls.

● Mounting screws are not included.

Shim (option)

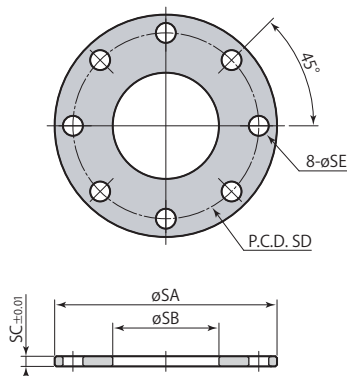

mm

Shim	CPS-S03D	CPS-S06D	CPS-S10D
øSA	54	67	74
øSB	24	32	39
SC	2.05	3.05	3.05
SD	43	56	61
øSE	6	6	7
Mass	0.06 kg	0.06 kg	0.07 kg

● This diagram indicates dimensions at shipping.

● Adjust thickness of shim by grinding to ensure flatness of pallet.

Mounting details

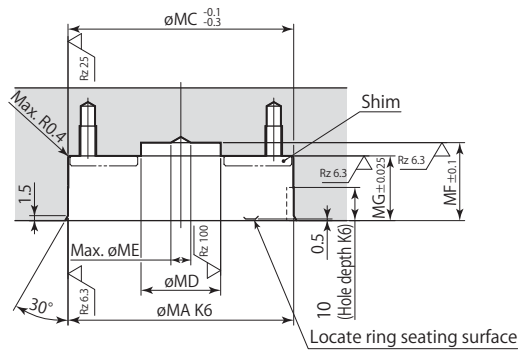
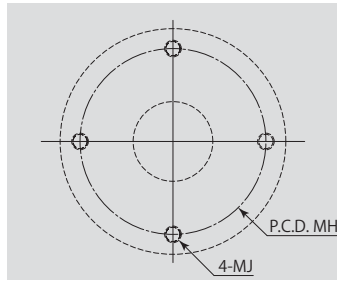

CPS-D03-10D, CPS-E03-10D, CPS-L03D

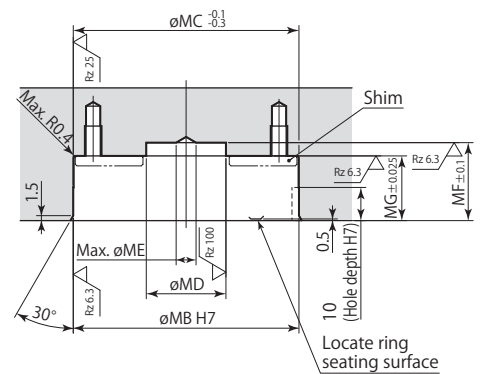

CPS-F03-10D

Rz: ISO4287(1997)

Model	CPS-□03D	CPS-□06D	CPS-□10D
øMA	55 ^{+0.004} _{-0.015}	68 ^{+0.004} _{-0.015}	75 ^{+0.004} _{-0.015}
øMB	55 ^{+0.025} ₀	68 ^{+0.030} ₀	75 ^{+0.030} ₀
øMC	55	68	75
øMD	20	24	28
øME	6	6	8
MF	20	23.5	26.8
MG	15.5	19.5	23.5
MH	43	56	61
MJ	M5	M5	M6

● Be sure to match up phase of locate ring steel ball grooves and pallet clamp steel balls.

Dimensions

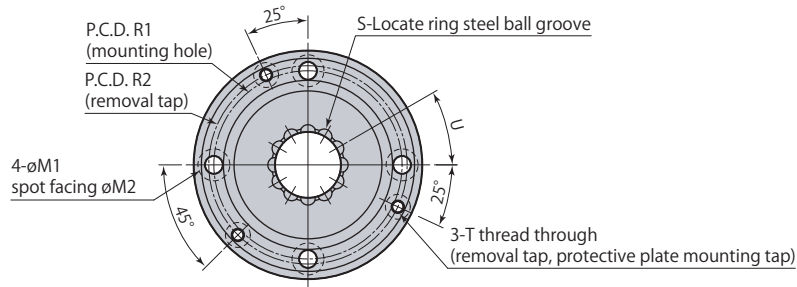

CPS-D03-10F Locate ring (D type)

CPS-E03-10F Locate ring (E type)
CPS-L03F Locate ring (L type)

CPS-F03-10F Locate ring (F type)

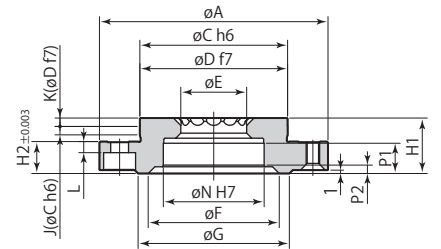
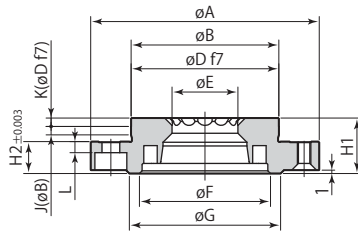
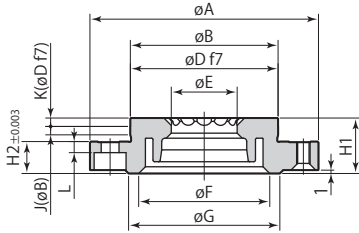

mm

Model	CPS-□03F	CPS-□06F	CPS-□10F
øA	55	68	75
øB	31 ^{+0.005} _{-0.011}	44 ^{+0.005} _{-0.011}	47 ^{+0.005} _{-0.011}
øC	31 ⁰ _{-0.016}	44 ⁰ _{-0.016}	47 ⁰ _{-0.016}
øD	31 ^{-0.025} _{-0.050}	44 ^{-0.025} _{-0.050}	47 ^{-0.025} _{-0.050}
øE	15.6	19.6	23.3
øF	28	39	42
øG	32	45	48
H1	15.5	16.5	20
H2	9	9.5	11.5
J	2.4	2.5	3.2
K	2.1	2.5	2.8
L	2.8	3.3	4.2
øM1	5.3	5.3	6.8
øM2	9.5	9.5	11
øN	22 ^{+0.021} ₀	30 ^{+0.021} ₀	32 ^{+0.025} ₀
P1	7	9	11
P2	2	2.5	2.5
R1	43	56	61
R2	46	59	64
S	8	12	12
T	M4×0.7	M4×0.7	M5×0.8
U*	45°	30°	30°

* : Be sure to match up phase of locate ring steel ball grooves and pallet clamp steel balls.

● Mounting screws are not included.

Shim (option)

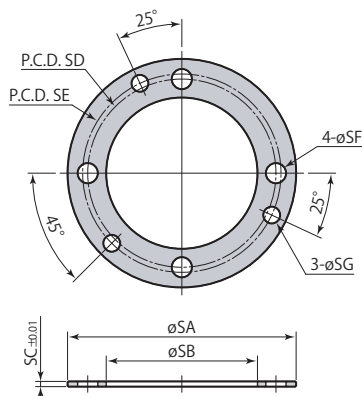

mm

Shim	CPS-S03F	CPS-S06F	CPS-S10F
øSA	55	68	75
øSB	32	45	48
SC	1.55	1.55	2.05
SD	43	56	61
SE	46	59	64
øSF	6	6	7
øSG	5	5	6
Mass	0.02 kg	0.02 kg	0.04 kg

● This diagram indicates dimensions at shipping.

● Adjust thickness of shim by grinding to ensure flatness of pallet.

Mounting details

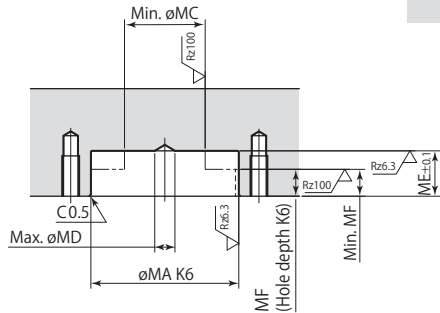
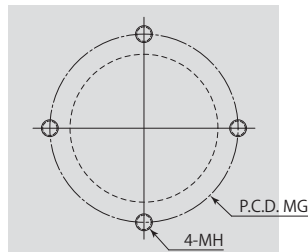

CPS-D03-10F, CPS-E03-10F, CPS-L03F

Rz: ISO4287(1997)

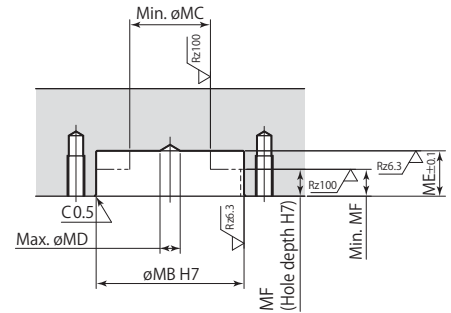

CPS-F03-10F

Model	CPS-□03F	CPS-□06F	CPS-□10F
øMA	31 ^{+0.003} _{-0.013}	44 ^{+0.003} _{-0.013}	47 ^{+0.003} _{-0.013}
øMB	31 ^{+0.025} ₀	44 ^{+0.025} ₀	47 ^{+0.025} ₀
øMC	20	24	28
øMD	6	6	8
MG	43	56	61
MH	M5	M5	M6

Not using shim (standard specifications)

ME	10.5	13.5	14.8
MF	7.5	8	9.5

Using shim (shim specifications)

ME	9	12	12.8
MF	6.5	6.5	7.5

● Be sure to match up phase of locate ring steel ball grooves and pallet clamp steel balls.

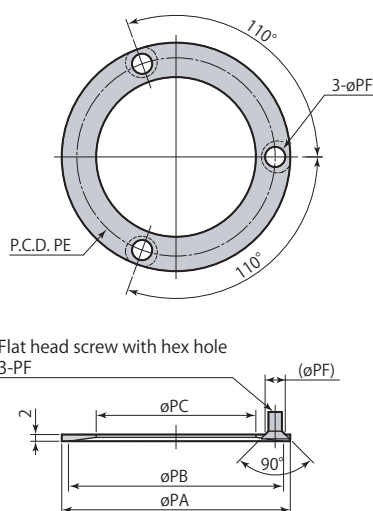

Protective plate (option)

Protective plate	CPS-P03F	CPS-P06F	CPS-P10F
øPA	55	68	75
øPB	51	64	68
øPC	34.5	47.5	50.5
PE	46	59	64
øPF	6	6	8
Mass	0.02 kg	0.02 kg	0.03 kg

Pitch tolerance of Pal system

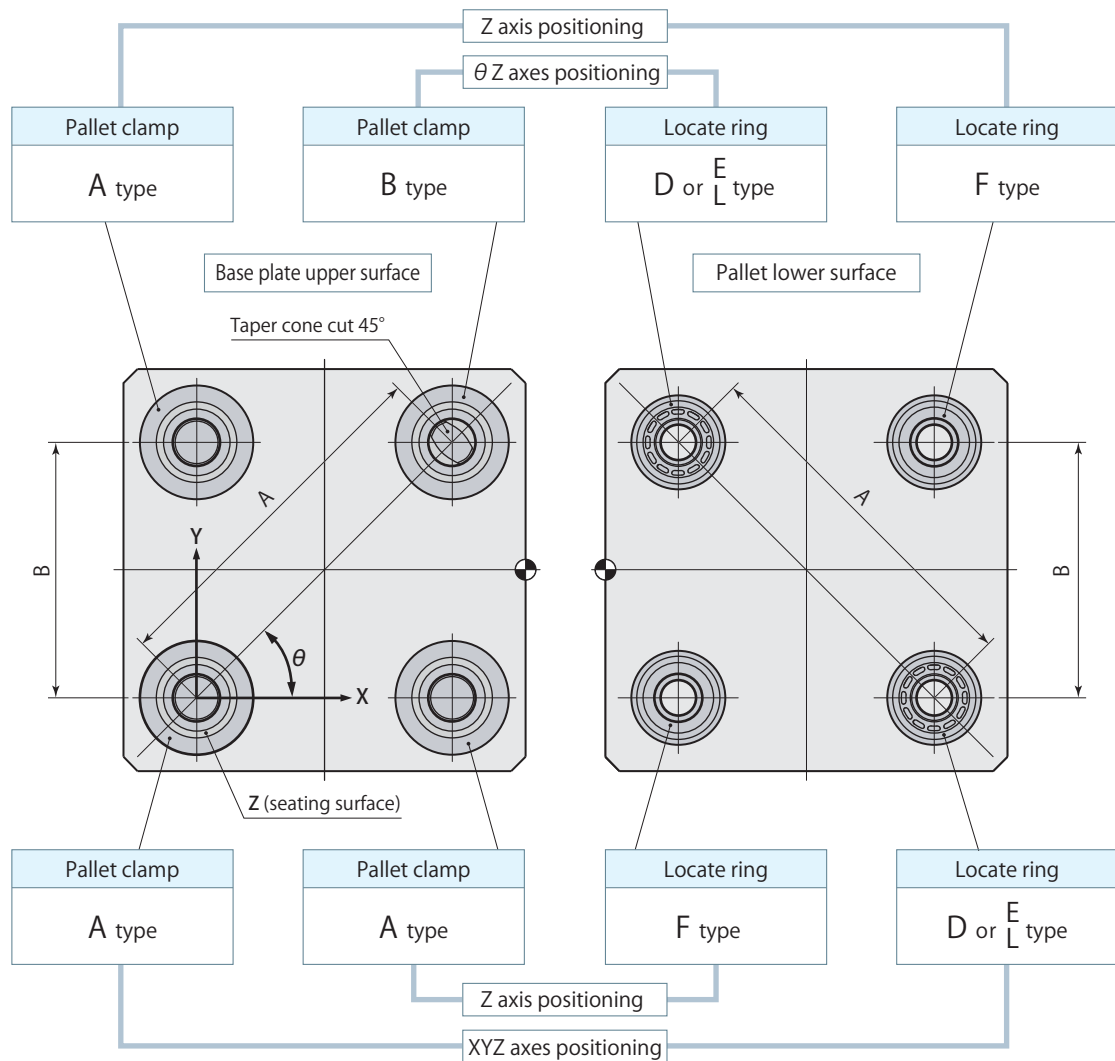

Pitch tolerance of A dimensions	±0.01 mm
Pitch tolerance of B dimensions	±0.03 mm

Method for positioning pallet changer setup table

Internal hole of model CPS-F (Seating surface positioning) can be used for positioning of setup table for pallet change with pallet changer. In order to sustain accuracy, do not allow surfaces other than those of pallet clamp model CPY to come into contact with tapered surface or seating surface.

Locate ring XYZ axes and θ Z axes positioning

Locate ring Z axis positioning

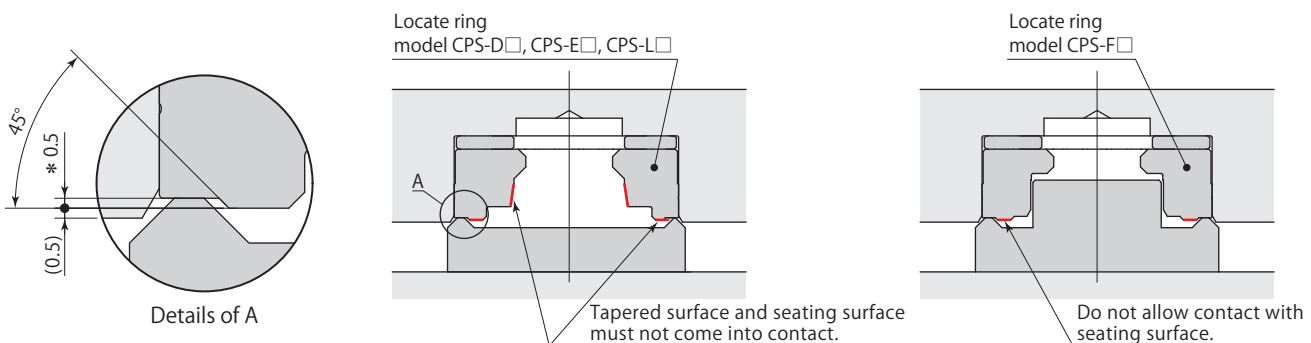

* : 1mm for CPS-□□F (Locate ring for flange mounting)

Pallet change

- When pallet changing, the pallet should be mounted or dismounted observing the figures shown in "Max. allowable eccentricity for pallet setting". (Refer to **page →41** for max. allowable eccentricity for pallet setting.)
- Ensure that pallet does not lean to the side when pallet mounting or dismounting. When dismounting pallet in particular, pulling while in a tilted condition can damage pallet clamp and locate ring. A guide pin is recommended to prevent the pallet from leaning.

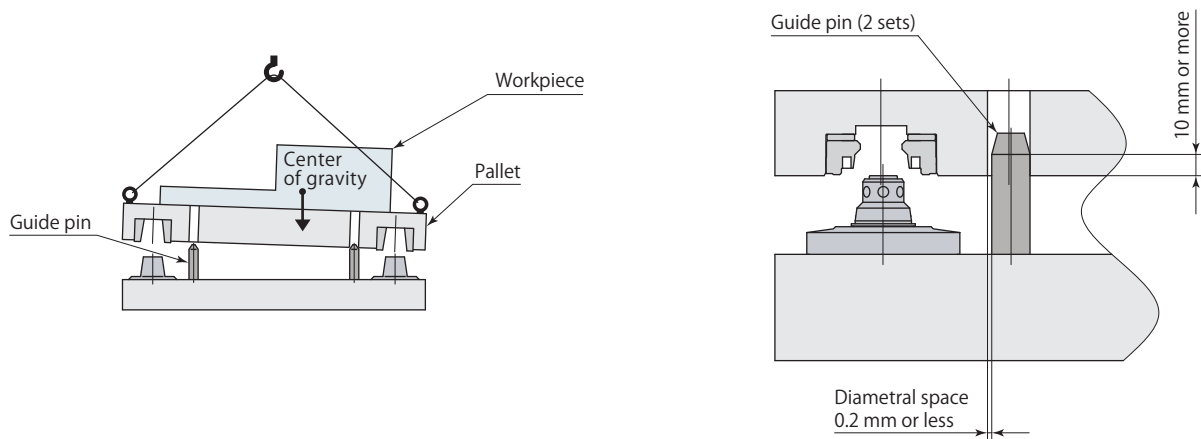

For vertical mounting of pallet

- A guide pin must be installed when mounting pallet vertically.
- Ensure spacing is set in order to ensure that mounted guide pin does not affect positioning.
- Ensure the pallet is closely contact with the base when it is clamped. Clamping with a space may cause the damage of both of clamp and locate ring.
(Refer to **page →47** for the height of pallet from base plate when pallet setting.)

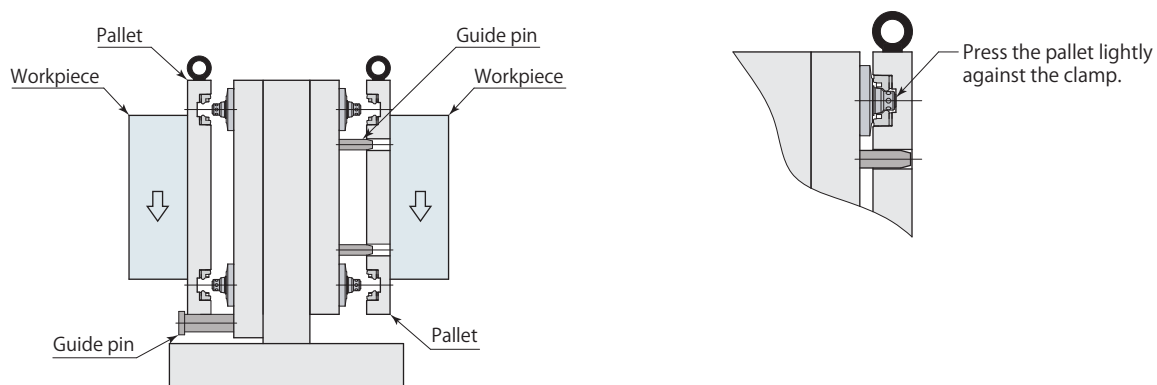

Level adjustment

Level adjustment of pallet clamp seating surface

- If level adjustment of pallet clamp seating surface is required, use pallet clamp shim (option). The level can be adjusted by grinding the shim.
- Grind shim upper surface (surface without O-ring).
- The measurement on the seating surface should be performed under the pallet clamped condition without locate rings.
(Recommended adjustment figure : $\pm 0.003\text{mm}$)

Level adjustment of locate ring seating surface

- If level adjustment of locate ring seating surface is required, use locate ring shim (option). The level can be adjusted by grinding the shim. (Recommended adjustment figure : $\pm 0.003\text{mm}$)

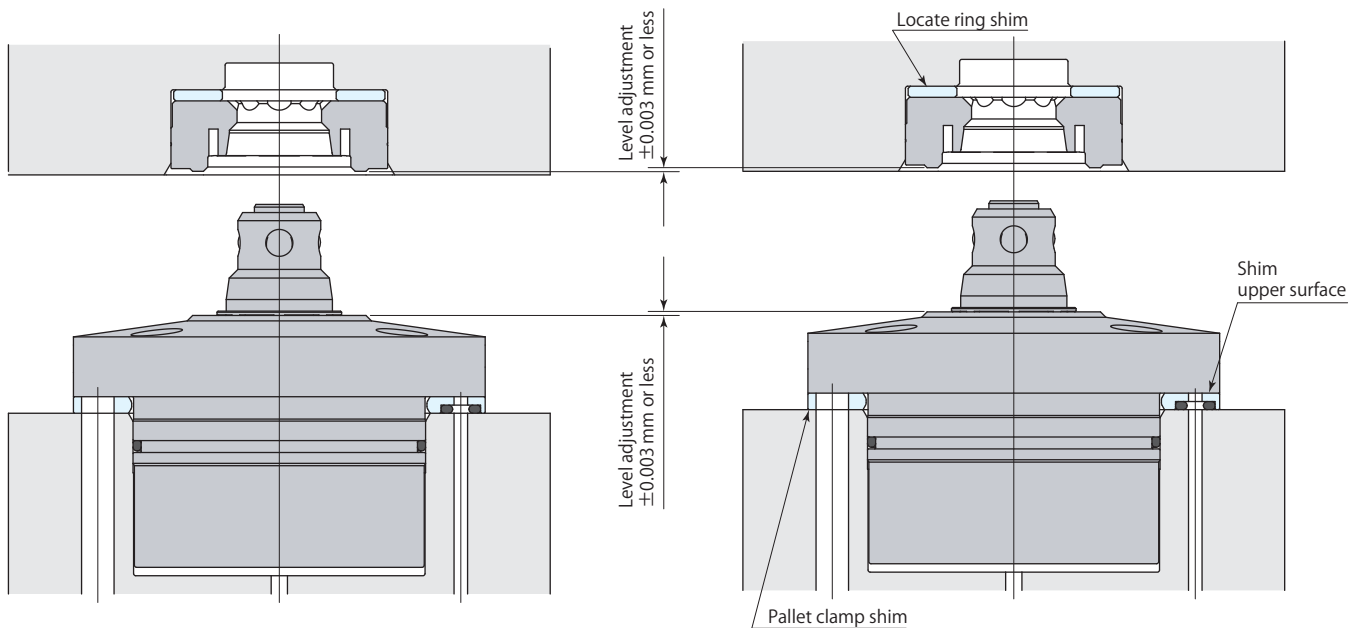

Dismounting of clamp

Dismounting of clamp

- ① Mount the set-screws on the mounting tap to protect the threads and clamp mounting surface.
- ② Mount the clamp removal screw on the clamp removal tap and dismount the clamp.
- ③ Retain the clamp upright condition when dismounting it.

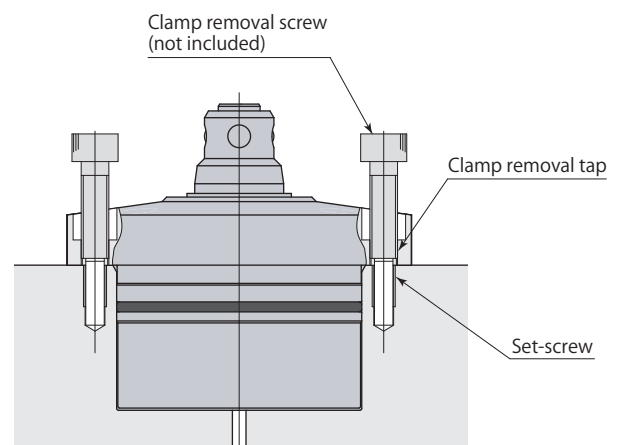

Air sensor recommended condition of use

Supplier and model	ISA3-F/G series manufactured by SMC
	GPS2-05, GPS3-E series manufactured by CKD
Air supply pressure	0.2 MPa
Inner diameter of piping	ø4 mm
Overall piping length	5 m or less

- Supply the dry and filtered air. Particulate size $5\ \mu\text{m}$ or less is recommended.
- Use a solenoid valve with needle for air sensor unit and control it supplying air all the time in order to eliminate intrusion of chips or coolant.

- There is a case that air sensing cannot be made successfully as designed when it is used out of the usage shown on the left. Contact Technical service center for more details.
- Refer to the sensor supplier's instruction manual for the details of setting.
- Sensing performance such as detectable time and pressure differs depending on the supplier and model number of the sensor. Select the right model referring to sensor's application and characteristics.
- Clamp state observation or operating check by the air sensor should be made while air blow is OFF.

Pneumatic circuit diagram

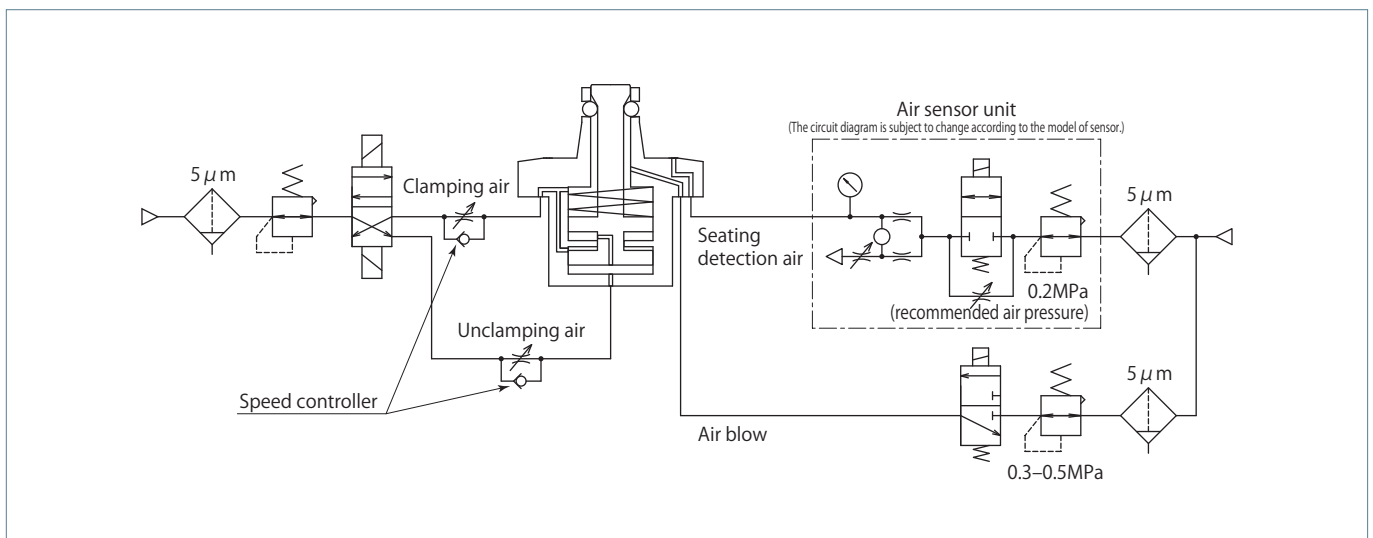

- Be sure to make inner diameter of air blow circuit 8 mm or more except for clamp mounting surface.
- Adjust full stroking time to be more than 1 second by a speed controller to avoid impact at the time of clamp or unclamp action.

Pal fix

Manual clamp

model **CPK**



Super-compact locating device makes you utilize a working space to the full.

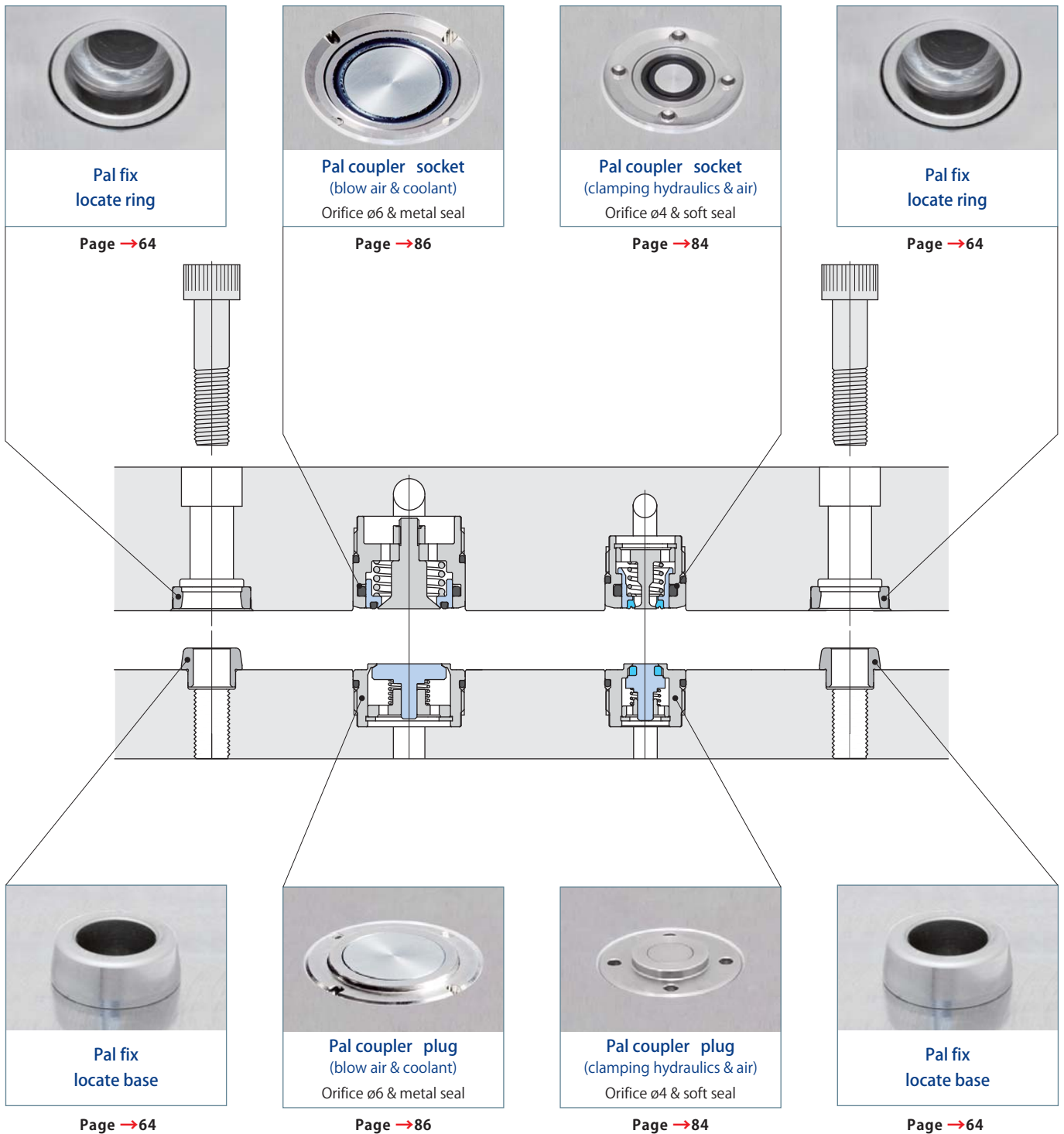

It is a taper cone model with dual surface contact to position high-accuracy.

Pallet change and coupler disconnected

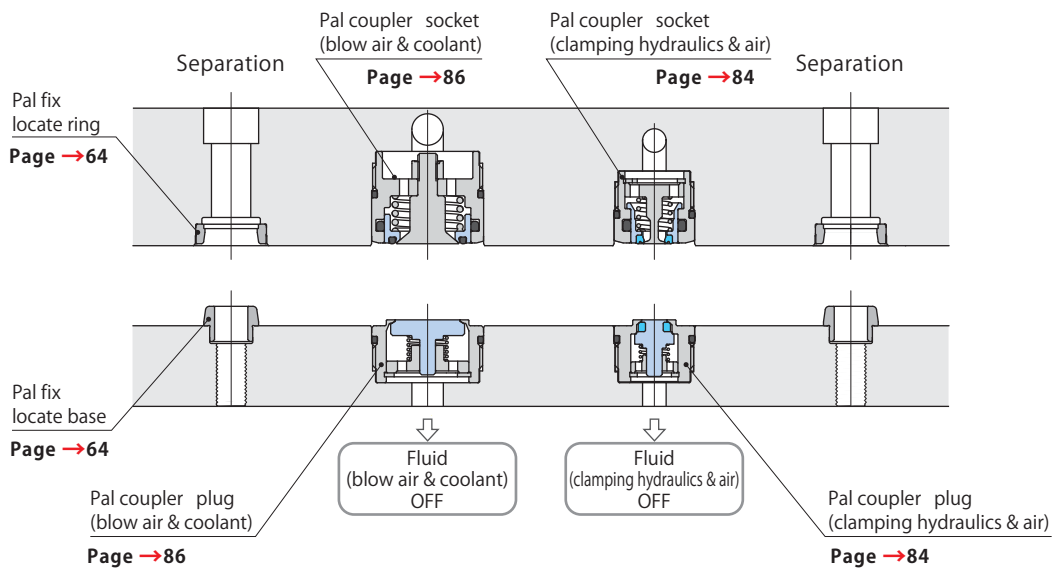

Pallet clamped and coupler connected

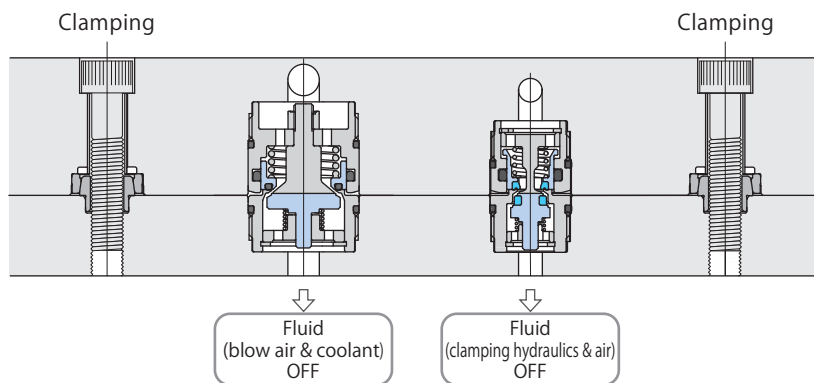

Precise positioning can be made by simply tightening the screws, and couplers can be connected at the same time.

Pallet clamped and circuit pressurized

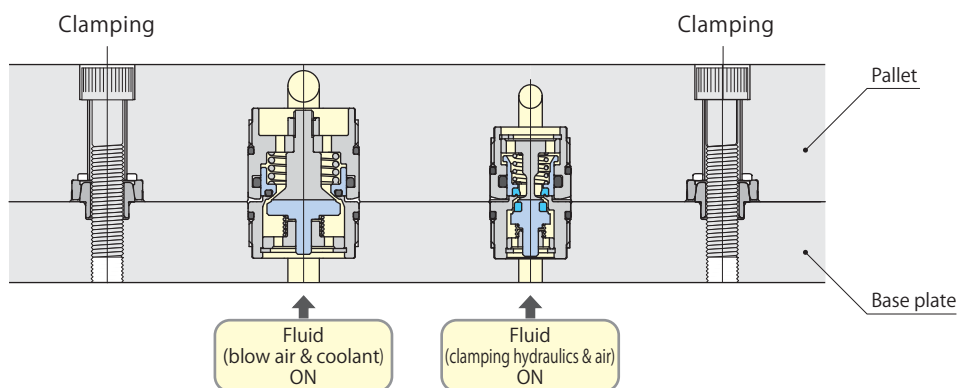

Pallet setting

- Bring pallet above the base plate. Lower it slowly after positioning. Pallet is centered along the tapered surface of the locate base.

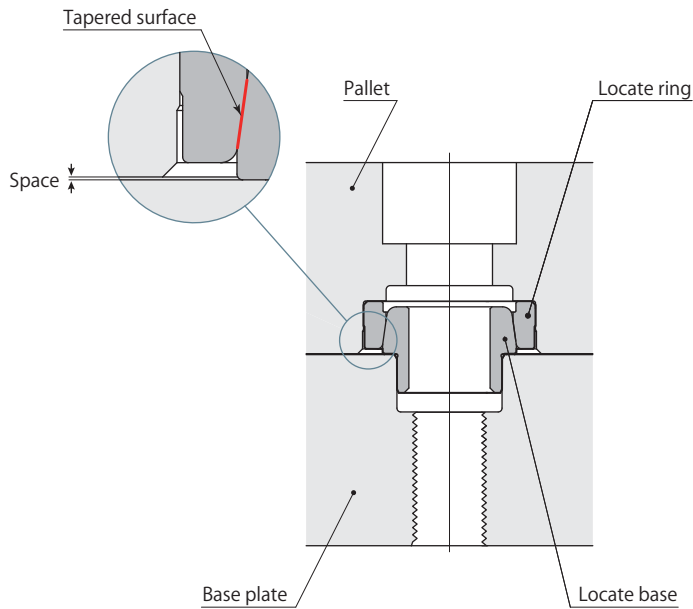

XYZ positioning (dual surface positioning)

- Tapered surface of locate ring is expanded and deformed in radial direction by the locate base to firmly position X axis and Y axis. Pallet is attached to seating surface of base plate and positions Z axis. The positioning of X, Y and Z axes by tapered surface and seating surface completes the XYZ positioning (dual surface positioning).

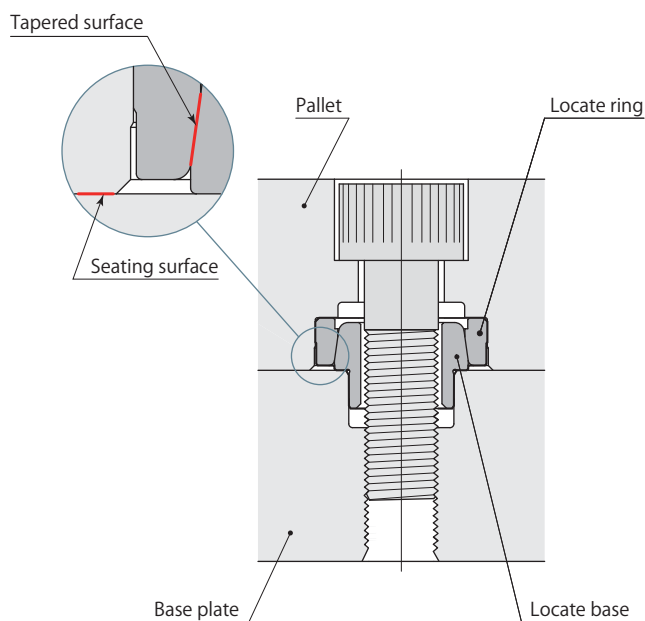

Realizing high-accuracy positioning

- In the case of ordinary positioning pin, it is common knowledge that the clearance is provided between the pin and the hole to allow the dimensional tolerance between the two pins, and to facilitate the positioning operation, however there is a risk of impairing the positioning repeatability depending on the volume of clearance so that the positioning re-adjustment must be done when re-setting the objects. Pal fix can exert $3\mu\text{m}$ of repeatability and requires no re-adjustment after setting the objects.

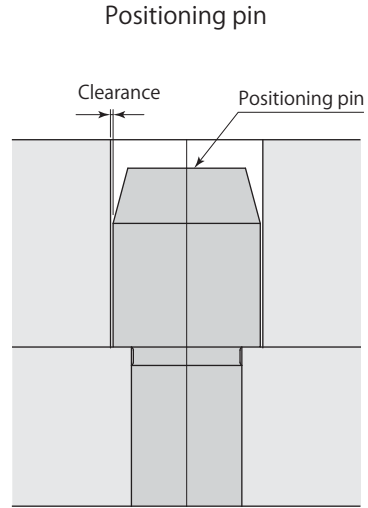
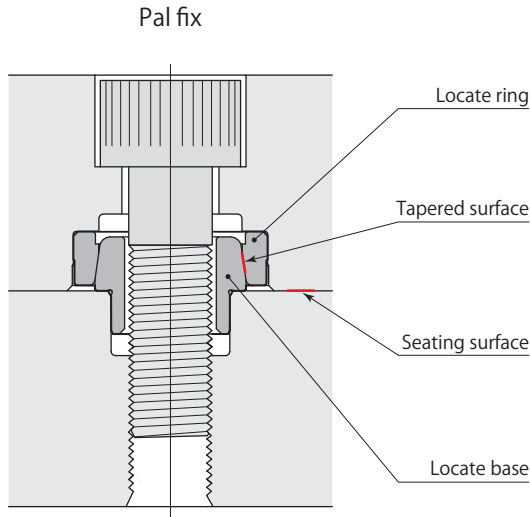

Taper cone makes attaching / detaching easy

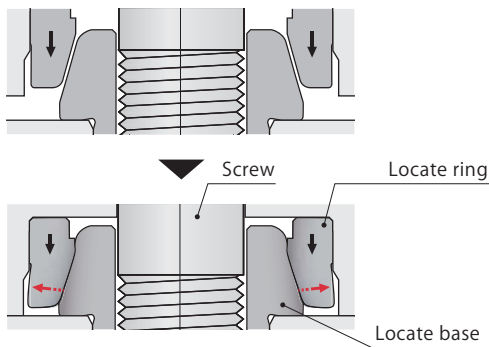

By means of elastic deformation

- Positioning repeatability : Within $3\mu\text{m}$
- Pitch tolerance allowance : $\pm 0.02\text{mm}$

Pal fix only keeps pitch accuracy.

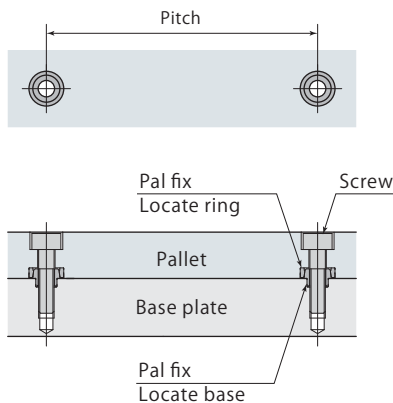

Round

Diamond

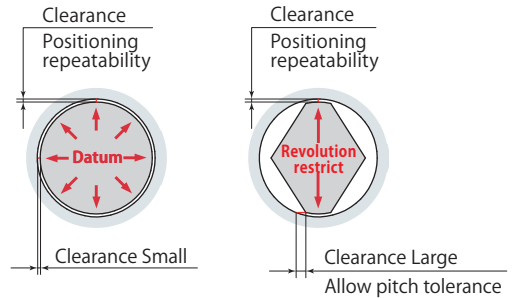

The positioning repeatability spoils when providing a large clearance. A small clearance impairs the operability.

The diamond pin must be mounted perpendicularly toward round pin in addition to keeping the pitch accuracy between the two.

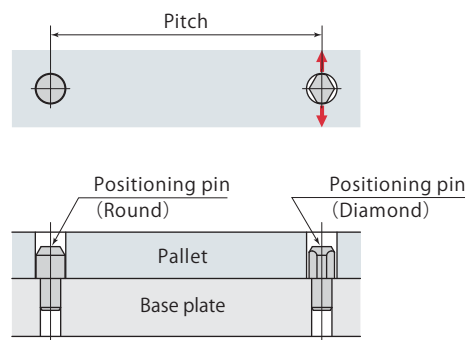

Combination of round and diamond pin

Pal fix

model **CPK** PAT.

The dual surface contact taper cone combines high precision machining (repeatability: $3 \mu\text{m}^*$) and makes attaching or detaching easy.

*: Repeatability dependent on mounting orientation and mass (weight)

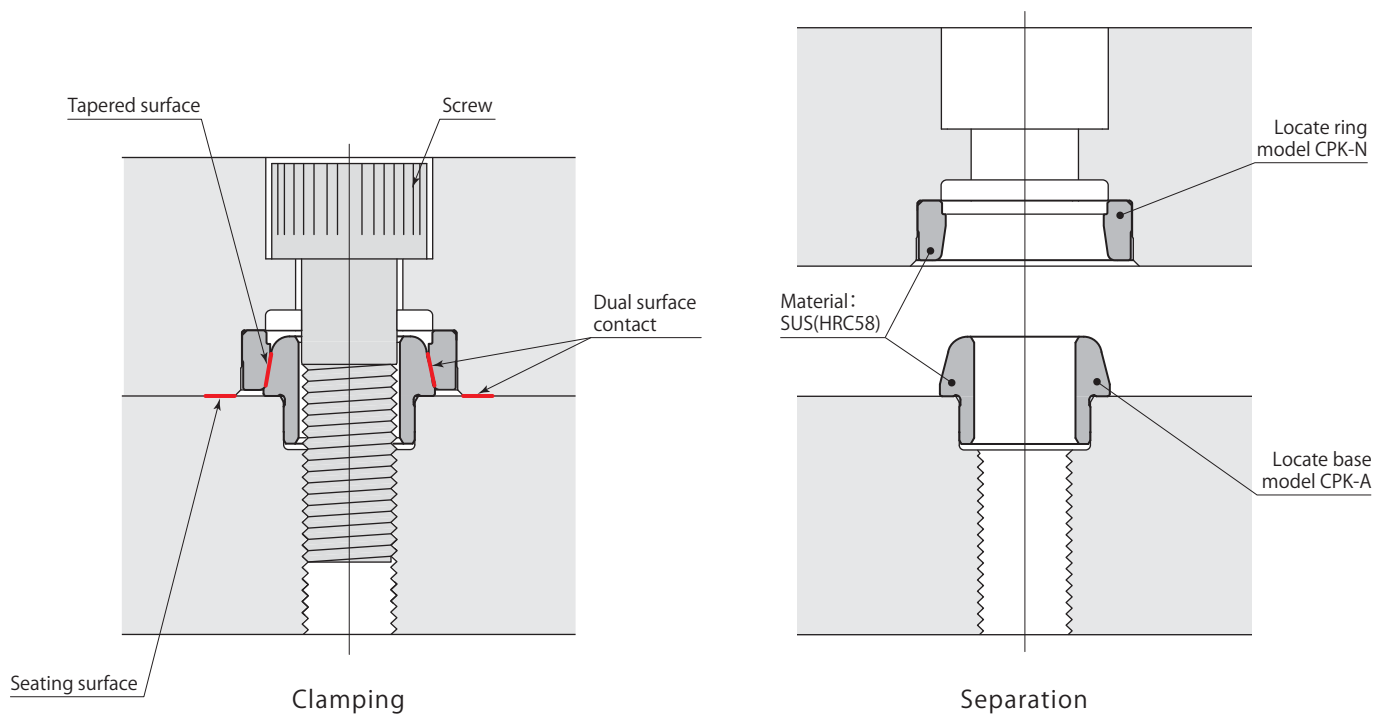

Specifications page → 67
 Dimensions page → 68
 Mounting details page → 69
 Option page → 71

Usage example

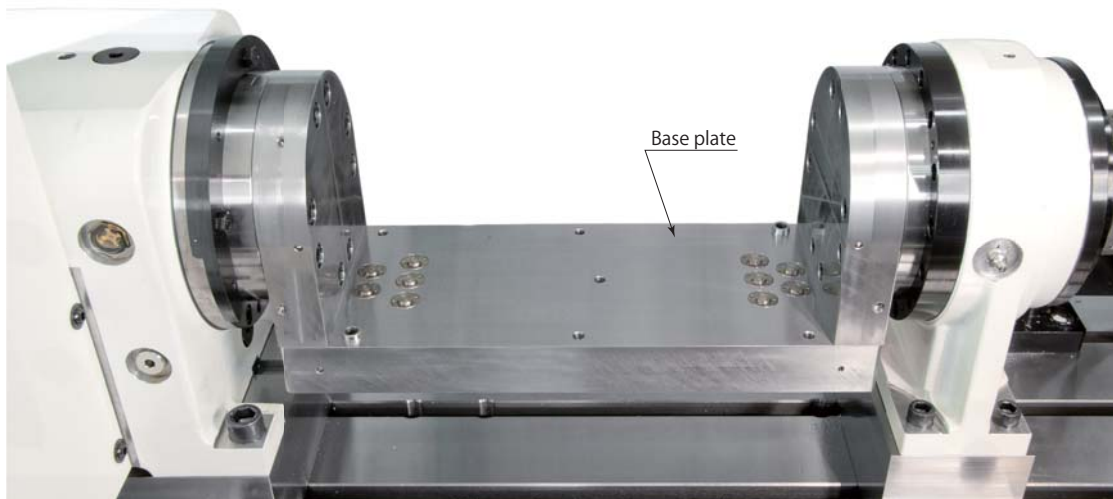
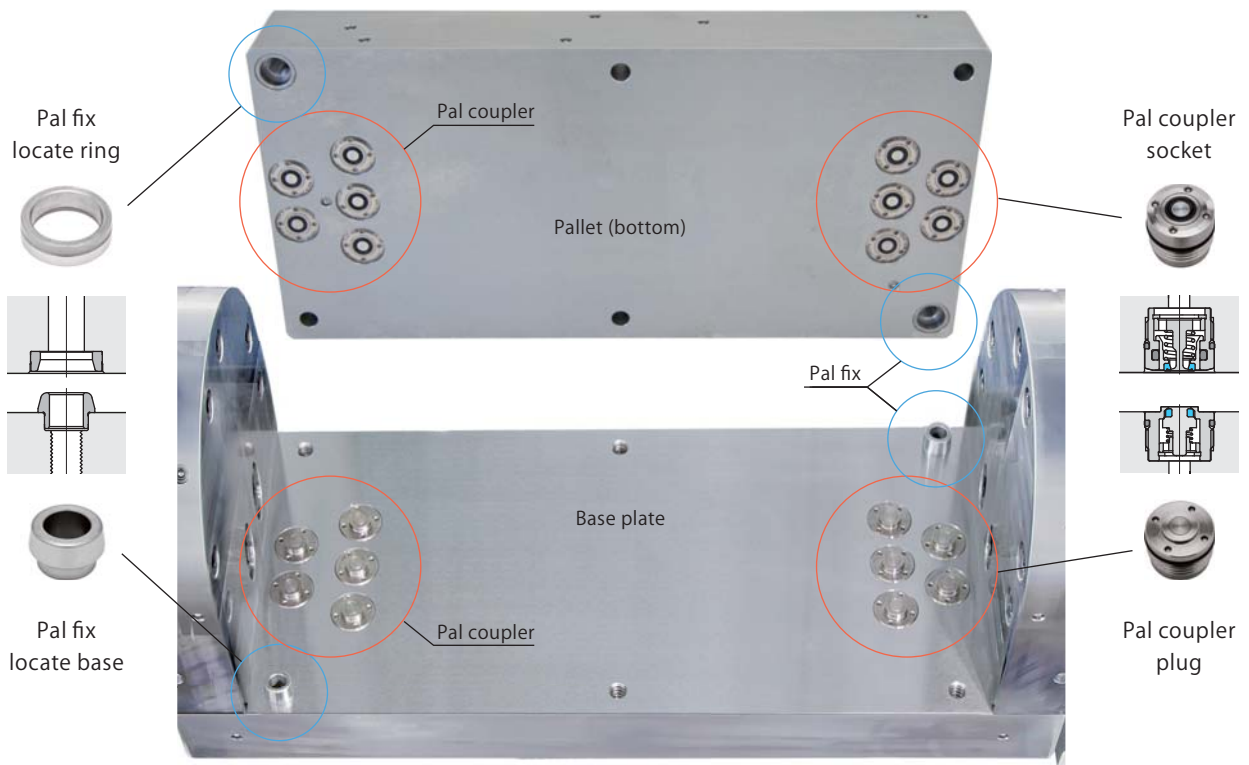

Compacting

Pal fix

Space (small)

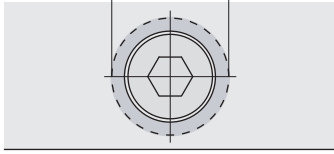

Space (small)

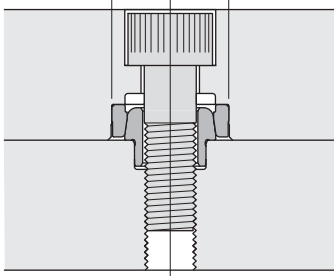

Positioning pin

Space (big)

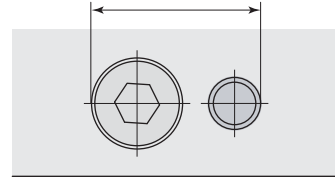

Space (big)

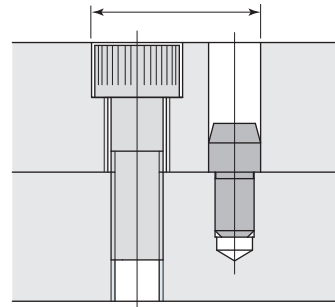

Easy attaching and detaching

Pal fix

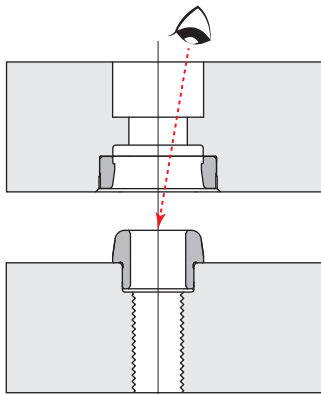

● Visual attaching and detaching.

Positioning pin

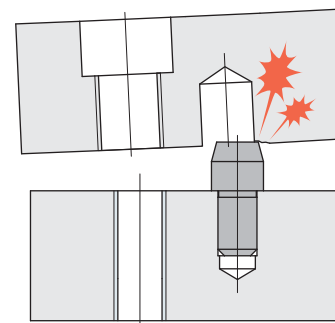

● With no visual, it is difficult to detach and attach. Seating surface will also be damaged.

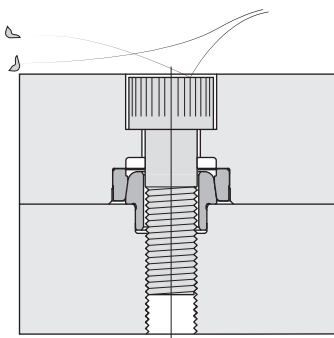

● Prevents intrusion of chips and foreign substances.

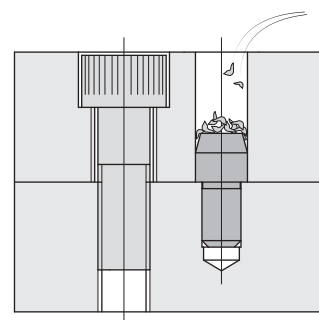

● Chips accumulate and are trapped, becoming difficult to remove.

Specifications

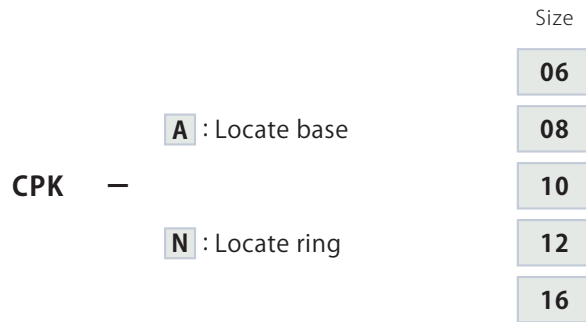

Model			CPK-□06	CPK-□08	CPK-□10	CPK-□12	CPK-□16	
Max. allowable load*1	Repeatability 3 μm	Horizontal mounting	kN	0.85	1.0	1.2	1.5	2.0
		Vertical mounting	kN	0.17	0.2	0.25	0.3	0.4
	Repeatability 5 μm	Horizontal mounting	kN	2.5	3.0	3.7	4.5	6.0
		Vertical mounting	kN	0.5	0.6	0.75	0.9	1.2
Min. clamping force*2			kN	7.5	9.0	12.5	15.5	21.5
Max. allowable eccentricity for pallet changing			mm	±0.5	±0.5	±0.5	±0.5	±1.0
Mass	Locate base		g	3.0	5.0	7.0	10.0	21.0
	Locate ring		g	3.0	4.0	7.0	11.0	22.0

*1: This is maximum allowable load of pallet, regardless of how many Pal fix are used.

*2: Indicates necessary force to position one pair of locate base and locate ring.



Scale 1:1

Dimensions

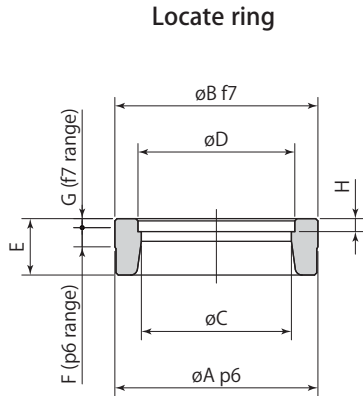

Locate ring

Model	CPK-N06	CPK-N08	CPK-N10	CPK-N12	CPK-N16
øA	15 ^{+0.029} / _{+0.018}	18 ^{+0.029} / _{+0.018}	22 ^{+0.035} / _{+0.022}	25 ^{+0.035} / _{+0.022}	32 ^{+0.042} / _{+0.026}
øB	15 ^{-0.016} / _{-0.034}	18 ^{-0.016} / _{-0.034}	22 ^{-0.020} / _{-0.041}	25 ^{-0.020} / _{-0.041}	32 ^{-0.025} / _{-0.050}
øC	10.9	13.3	16.1	18.4	24
øD	11.4	13.9	16.9	19.4	25.2
E	4.5	5	6	7	9
F	1.7	1.7	1.7	1.7	2
G	0.8	0.8	1	1.3	2
H	1.15	1.15	1.15	1.15	1.35

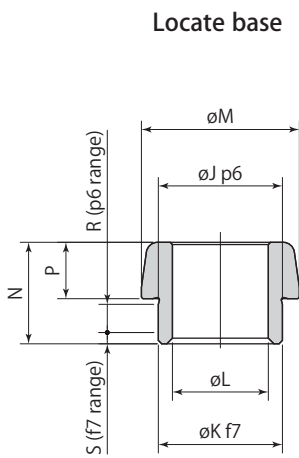

Locate base

Model	CPK-A06	CPK-A08	CPK-A10	CPK-A12	CPK-A16
øJ	9 ^{+0.024} / _{+0.015}	11 ^{+0.029} / _{+0.018}	14 ^{+0.029} / _{+0.018}	16 ^{+0.029} / _{+0.018}	21 ^{+0.035} / _{+0.022}
øK	9 ^{-0.013} / _{-0.028}	11 ^{-0.016} / _{-0.034}	14 ^{-0.016} / _{-0.034}	16 ^{-0.016} / _{-0.034}	21 ^{-0.020} / _{-0.041}
øL	6.5	8.5	11	13	17
øM	11.5	14	17	19.5	25.5
N	8.5	9	10	11.5	13.5
P	4.5	5	6	7	9
R	2.5	2.5	2.5	3	3
S	1	1	1	1	1

Mounting details

Locate ring mounting details

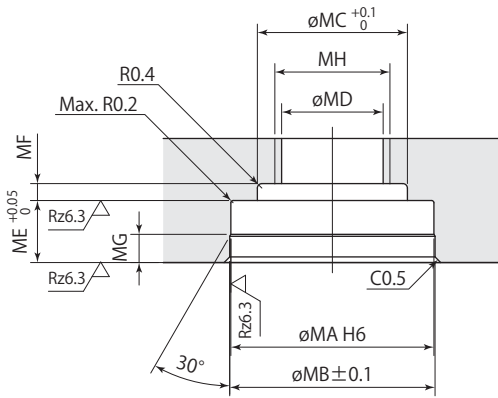

Rz: ISO4287(1997)

mm

Model	CPK-N06	CPK-N08	CPK-N10	CPK-N12	CPK-N16
ϕMA	15 $+0.011/0$	18 $+0.011/0$	22 $+0.013/0$	25 $+0.013/0$	32 $+0.016/0$
ϕMB	15.2	18.2	22.2	25.2	32.2
ϕMC	11.6	14.2	17.5	20.0	25.8
ϕMD	6.8	9	11	14	18
ME	5	5.5	6.5	7.5	9.5
MF	1.5	1.5	2	2	2
MG	2	2.5	3.5	4	5
MH*	M8	M10	M12	M16	M20

* : Thread MH is provided to mount model CPK-N.

Refer to **page →71** for mounting method.

● Refer to **page →70** for mounting pitch tolerance.

Locate base mounting details

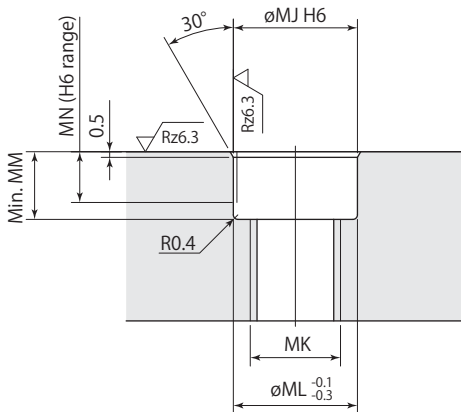

Rz: ISO4287(1997)

mm

Model	CPK-A06	CPK-A08	CPK-A10	CPK-A12	CPK-A16
ϕMJ	9 $+0.009/0$	11 $+0.011/0$	14 $+0.011/0$	16 $+0.011/0$	21 $+0.013/0$
MK	M6	M8	M10	M12	M16
ϕML	9	11	14	16	21
MM	5.5	6	6	7	7
MN	4.5	4.5	4.5	5	5

● Refer to **page →70** for mounting pitch tolerance.

Mounting pitch tolerance

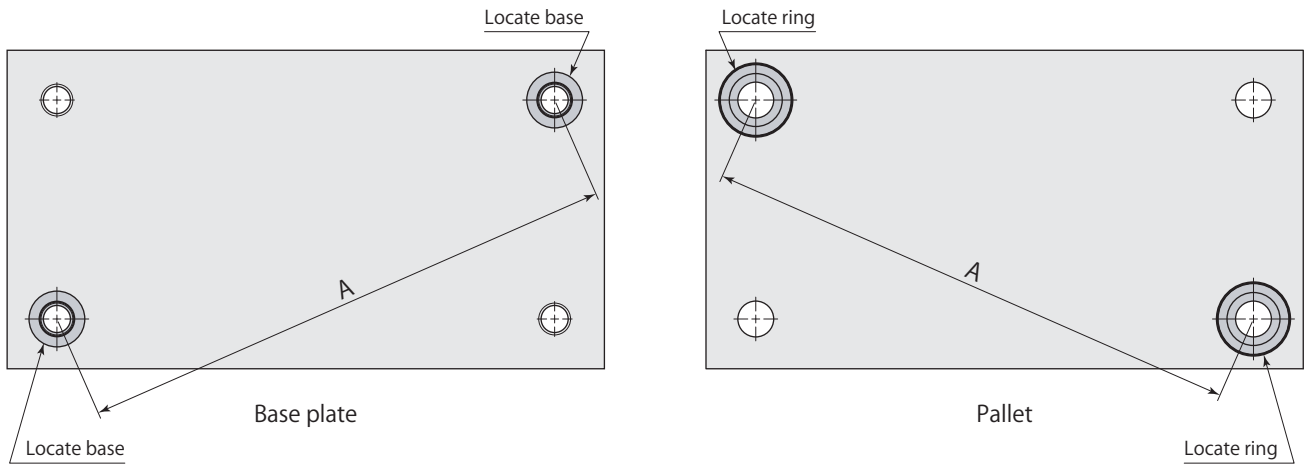

Pitch tolerance of A dimension

 $\pm 0.02 \text{ mm}$

Tightening turn for screws

- ① Tighten the screw up by hand until the seating surface of screw holding to other.
 - ② Tighten the screws tentatively in order as shown in the diagram on the right with a minimum force. (**page →67**)
 - ③ Tighten all of the screws again in order shown in the diagram.
- Make sure to tighten all screws evenly. Make sure not to give extra force only one or two screws on the same side. (e.c. : 1 and 3 on the right drawing.)

Tightening turn for screws

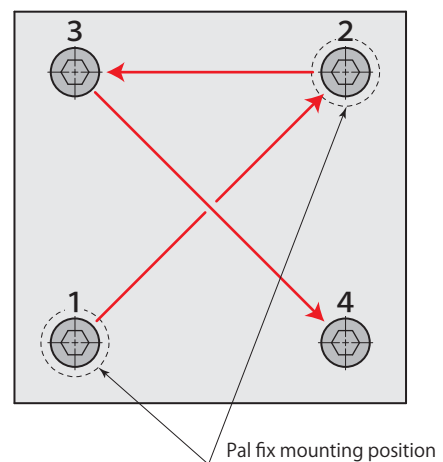

Mounting of locate ring

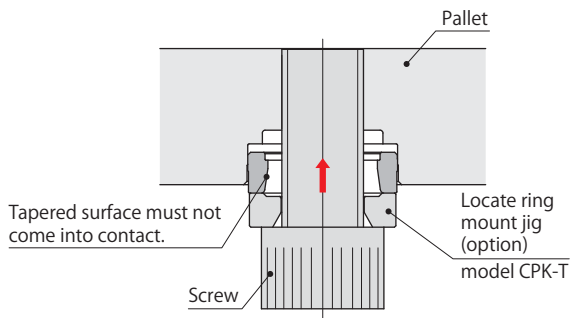

- Press a locate ring in the hole keeping it upright.

Dismounting of locate ring

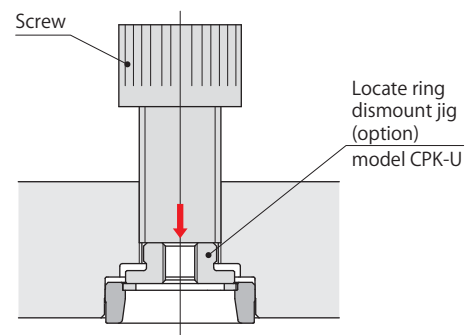
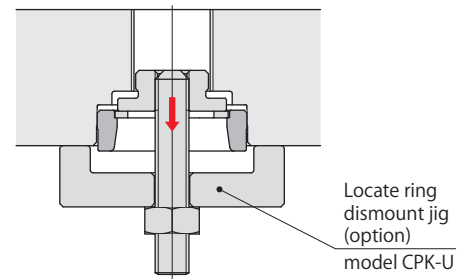

- The ring can be removed by a screw.

Mounting of locate base

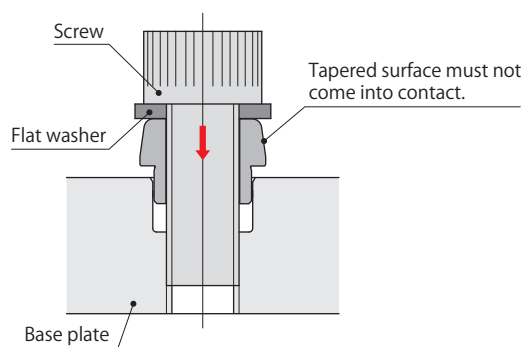

- Press a locate base in the hole keeping it upright. Be sure to use a flat washer to protect the locate base from damage.

Dismounting of locate base

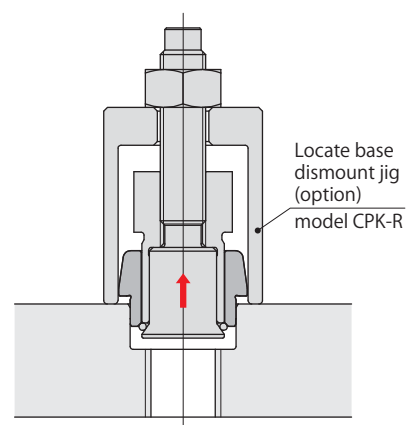

- Ask Pascal in the use of dismantling jig of locate ring and locate base.

Size

06

08

10

12

16

T : Locate ring mount jig

CPK —

U : Locate ring dismount jig

Locate ring mount jig

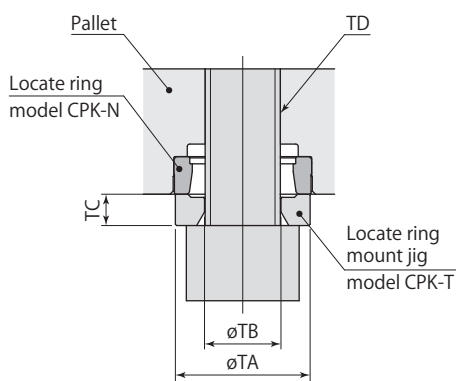

Locate ring dismount jig

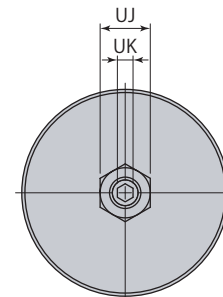
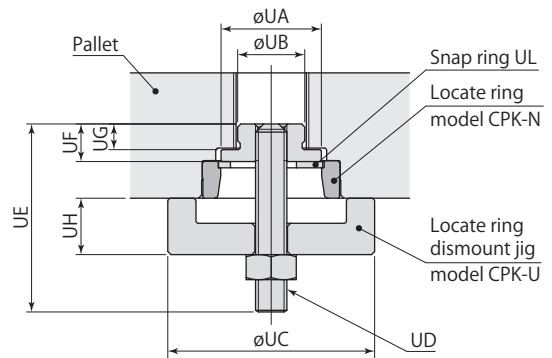

mm

Locate ring mount jig	CPK-T06	CPK-T08	CPK-T10	CPK-T12	CPK-T16
Locate ring dismount jig	CPK-U06	CPK-U08	CPK-U10	CPK-U12	CPK-U16
øTA	14.5	17.5	21.5	24.5	31.5
øTB	8.2	10.2	12.2	16.2	20.2
TC	4	4	5	5	6
TD	M8	M10	M12	M16	M20
øUA	10.8	13.2	16	18.3	23.9
øUB	6.5	8.7	10.7	13.7	17.7
øUC	25	27	33	35	43
UD	M4×0.7	M4×0.7	M5×0.8	M5×0.8	M6×1.0
UE	25	25	30	30	40
UF	5.5	5.5	6	6.5	9
UG	4.1	4.1	4.1	4.6	7.1
UH	8	8	9	9.5	11.5
UJ (nut width across flats)	7	7	8	8	10
UK (hex socket)	2	2	2.5	2.5	3
UL*	RTW-11	RTW-13	RTW-16	RTW-18	RTW-24
Locate ring	CPK-N06	CPK-N08	CPK-N10	CPK-N12	CPK-N16

* : Snap ring is made by Ochiai Corporation.

Size

06

08

10

12

16

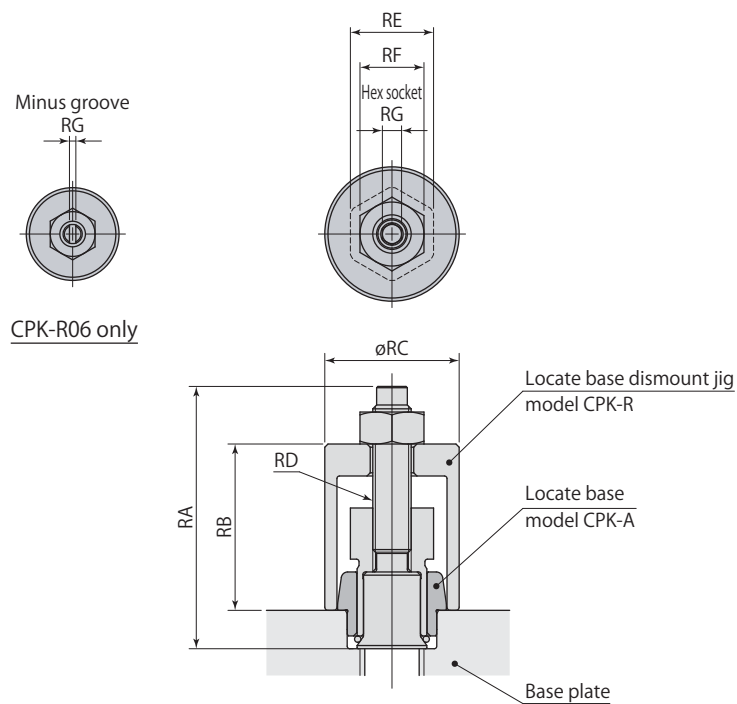
CPK — **R** : Locate base dismount jigLocate base dismount jig

Locate base dismount jig	CPK-R06	CPK-R08	CPK-R10	CPK-R12	CPK-R16
RA	33	36.5	41	43.5	55.5
RB	20.5	22.5	26	27.5	37
øRC	14.5	17	21	24	31
RD	M4×0.7	M5×0.8	M6×1.0	M6×1.0	M8×1.25
RE (hex width across flats)	10	10	13	17	22
RF (nut width across flats)	7	8	10	10	13
RG	1	2.5	3	3	4
Locate base	CPK-A06	CPK-A08	CPK-A10	CPK-A12	CPK-A16

Clamping

- Put the screws through Pal fix and tighten it.
Failure of the instruction may cause impair the repeatability.

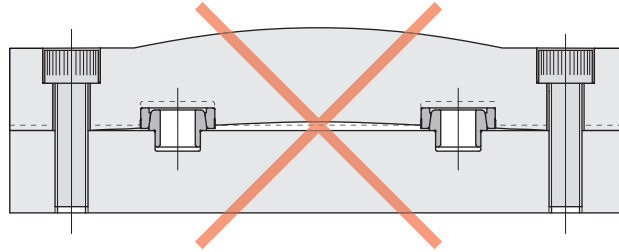

Mounting

- Make sure if locate base, locate ring are securely pressed into the end of the mounting hole.
Insufficient press-fit may cause mis-seating and excessive deformation, which results in breakage.

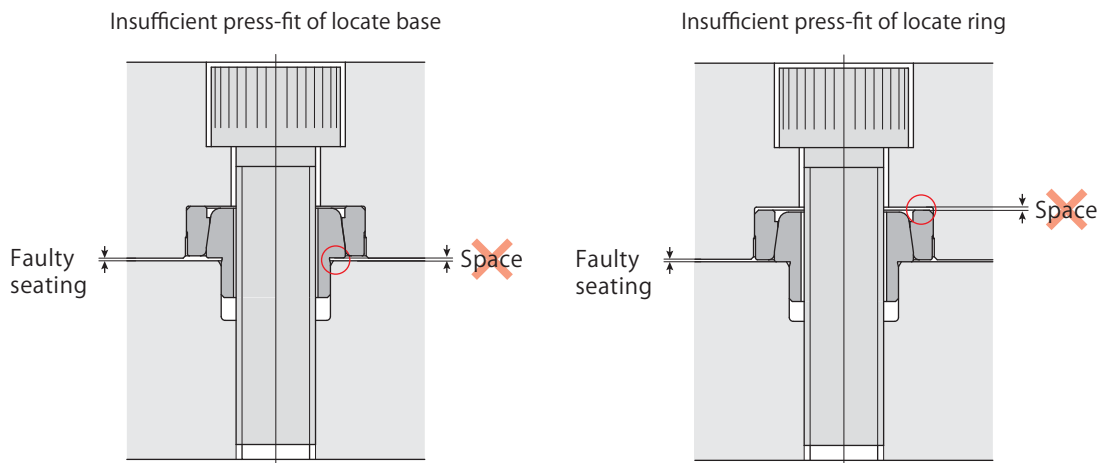

Defining fastening power

- Define the fastening power based on the load from the side.

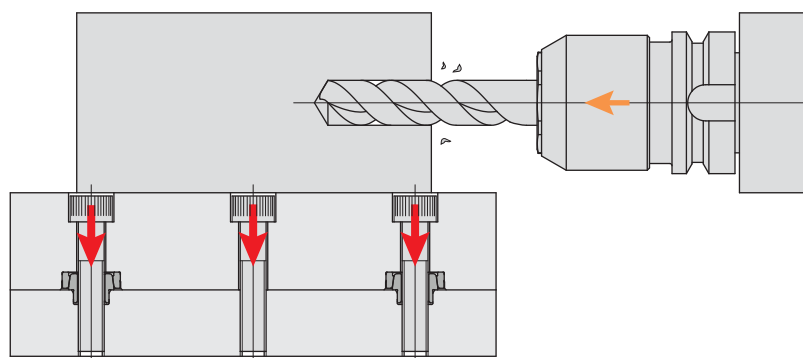

Reactive force of coupler

- Reactive force is generated when Pal couplers are used. The fastening power should be determined considering the reactive force of the coupler.

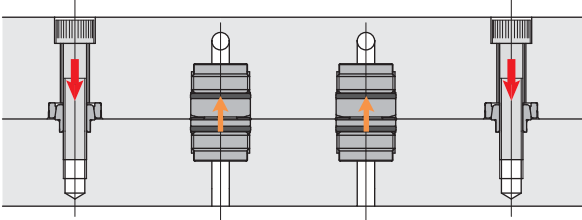

Fall protection

- The mechanical stopper must be provided to avoid pallet falling when changing the pallet.

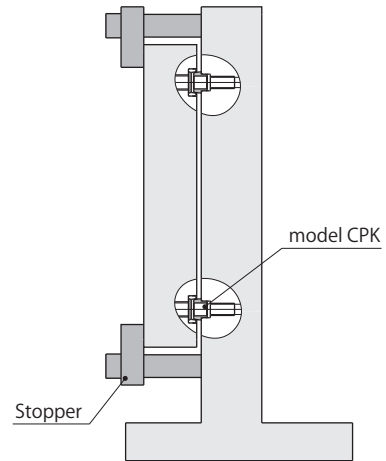

Cleaning

- Keep the seating and tapered surface clean.

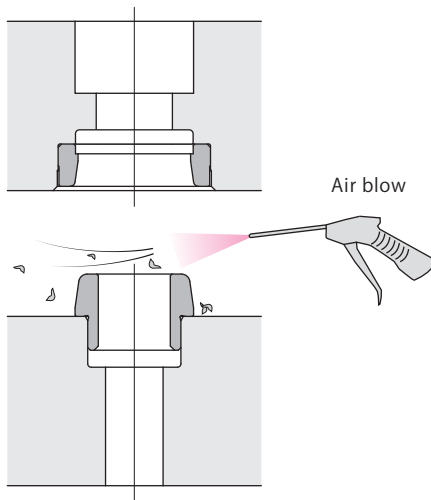

Max. allowable eccentricity

- Keep allowable eccentricity when loading or unloading the pallet.
(Refer to **page →67** for max. allowable eccentricity.)

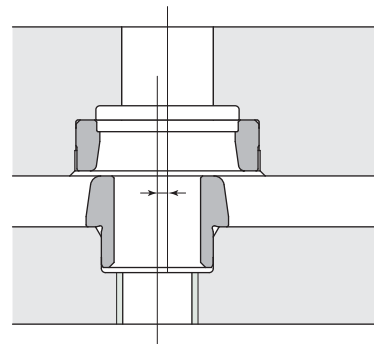

Coupler

model **WVP**



Pal coupler Hydraulic pressure 25MPa & air
model WVP-2BSH model WVP-2BPH



Pal coupler Air & coolant
model WVP-3DSN model WVP-3DPN



Pal coupler Hydraulic pressure 7MPa & air
model WVP-2FSL model WVP-2FPL



Pal coupler Air & coolant
model WVP-3GSN model WVP-3GPN



Pal coupler Air
model WVP-1FSN model WVP-1FPL



Pilot coupler Hydraulic pressure 7MPa
model WVP-2ESL model WVP-2EPL



Non-leak coupler Hydraulic pressure 7MPa
(Plug hydraulic pressure source)
model WVP-2HSL model WVP-2HPL



Non-leak coupler Hydraulic pressure 7MPa
(Socket hydraulic pressure source)
model WVP-2SSL model WVP-2SPL

Hydraulic and air coupler with zero hydraulic oil leak with special seal at tip section

Pal coupler socket
Hydraulic pressure 25 MPa & air
model **WVP-2BSH**



Pal coupler plug
Hydraulic pressure 25 MPa & air
model **WVP-2BPH-□□**

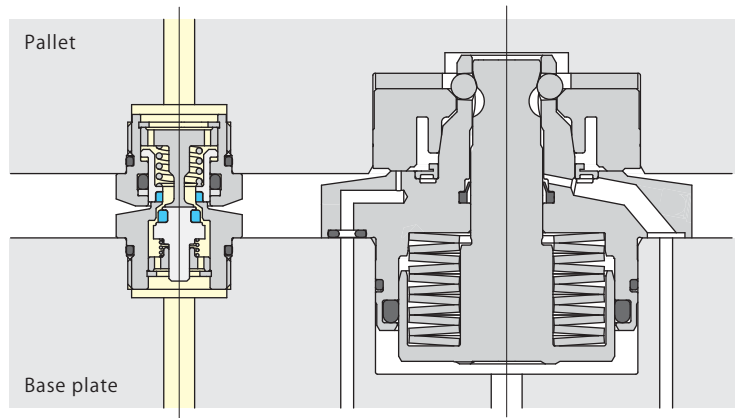

Coupling at same time with pallet clamp

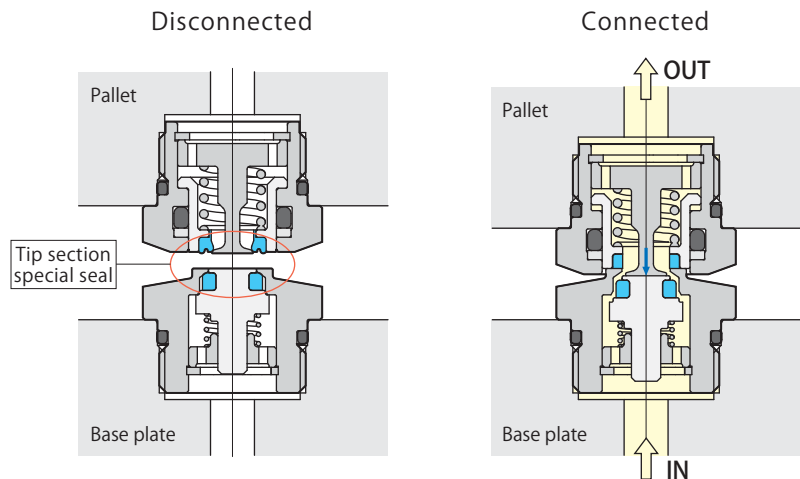

- Special soft seal at tip section enables plug (WVP-2BPH) to be pressurized under disconnected state. Socket (WVP-2BSH) can retain residual pressure of up to 0.3 MPa.
- Special seal installed on the tip of coupler socket and coupler plug can minimize the intrusion of air and spill of working fluid during connection and disconnection, furthermore, it prevents corruption of coolant by being miscible with spilled working fluid and air contamination of clamp circuit.
- Disconnection and connection of coupler is performed by lift stroke of pallet clamp and there is no need for connecting mechanism or stopper. No reactive force is generated when pallet is set, since coupler is not connected. (Refer to **page →3**)
- The couplers are selectable according to the size of pallet clamp and no spacer block is required.
- Height of coupler is maintained low in order to reduce thickness of pallet.
- The parts in the coupler are corrosion prevented (plating or stainless) and oil and air can be applied as a fluid.

Specifications

Pressure range	0–25 MPa	Circuit symbol
Proof pressure	37.5 MPa	
Orifice area	10.2 mm ²	
Fluid used	General mineral based hydraulic oil (ISO-VG32 equivalent) & air	
Allowable eccentricity	±0.5 mm	
Allowable inclination	0.3° or less	
Reactive force*	113 N per 1 MPa fluid pressure	
	Max. spring force for no pressure 40 N	
Operating temperature	0–70 °C	

* : Reactive force (N) = Fluid pressure (MPa) × 113 + 40

● Refer to **pages →80, 81** for details.

Air & coolant coupler with large orifice area and capability to accommodate large flow rates.

Pal coupler socket
Blow air & coolant
model **WVP-3DSN**



Pal coupler plug
Blow air & coolant
model **WVP-3DPN-□□**

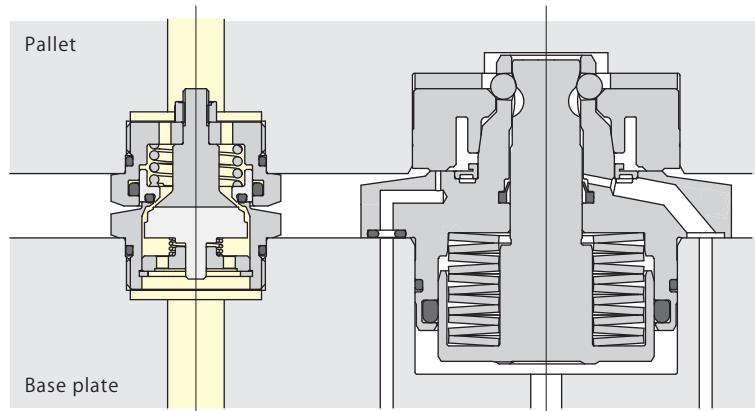

Coupling at same time with pallet clamp

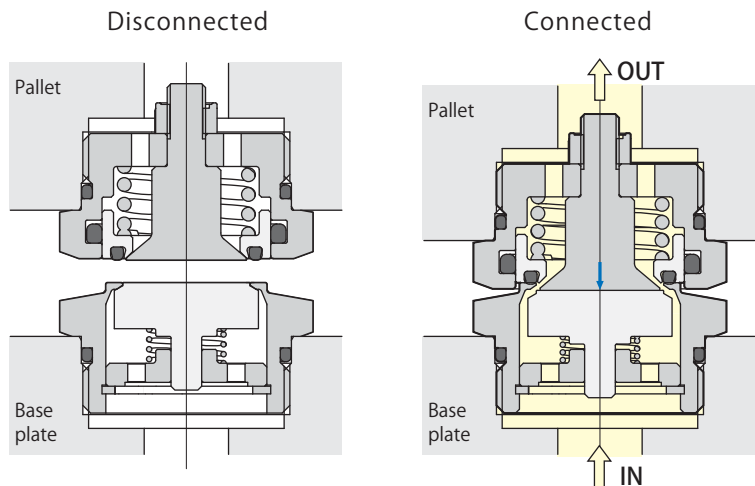

Specifications

- Height of coupler is maintained low in order to reduce thickness of pallet.
- Disconnection and connection of coupler is performed by lift stroke of pallet clamp and there is no need for connecting mechanism or stopper. No reactive force is generated when pallet is set, since coupler is not connected. (Refer to **page →3**)
- The couplers are selectable according to the size of pallet clamp and no spacer block is required.
- Large orifice area allows to supply large volume of coolant or blow air.

Pressure range	0–1 MPa	Circuit symbol Air & coolant Connect/disconnect : Incapable under pressure
Proof pressure	1.5 MPa	
Orifice area	29.0 mm ²	
Fluid used	Air & coolant	
Allowable eccentricity	±0.5 mm	
Allowable inclination	0.3° or less	
Reactive force*	380 N per 1 MPa fluid pressure Max. spring force for no pressure 60 N	
Operating temperature	0–70 °C	

* : Reactive force (N) = Fluid pressure (MPa) × 380 + 60

● Refer to **pages →82, 83** for details.

Dimensions

WVP-2BSH

Hydraulic pressure 25 MPa & air socket
Recommended tightening torque: 25 N·m

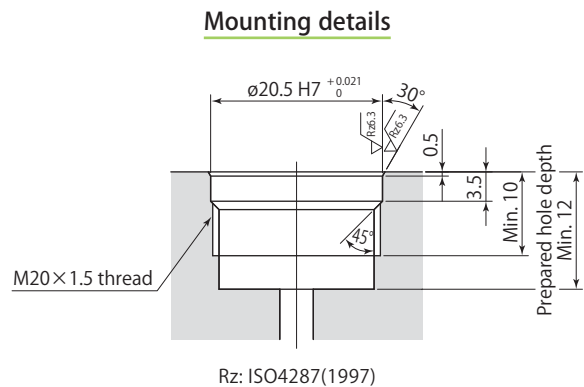
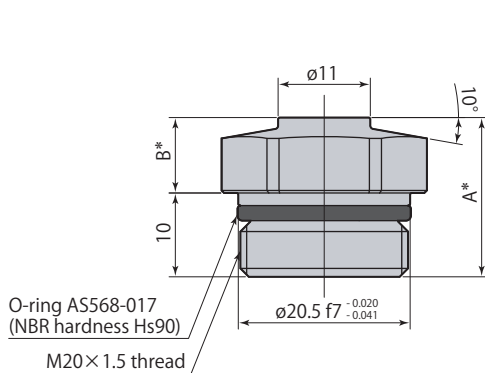
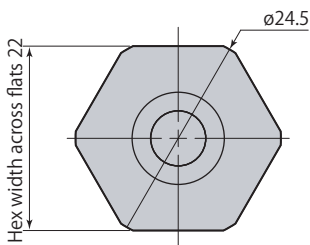
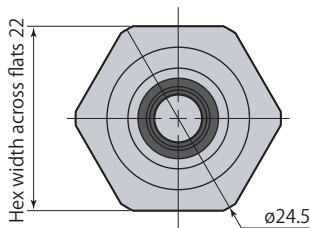
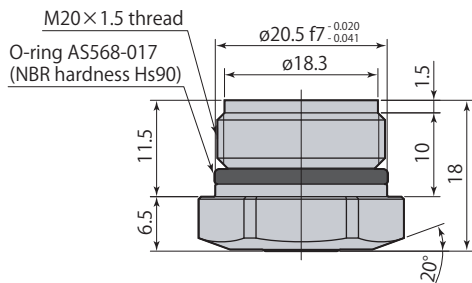

- Stop supplying fluid during disconnection and connection operations. Disconnecting or connecting coupler while fluid is flowing results in the leakage.
- Coupler has no built in filter. Ensure that foreign substances on connecting surfaces are removed by blowing air before connecting to prevent intrusion of foreign substances into piping.
- Make sure air bleeding in the hydraulic circuit is perfectly done when installation.

WVP-2BPH-10A, 16F, 25F, 40F
WVP-2BPH-16S, 25S, 40S only

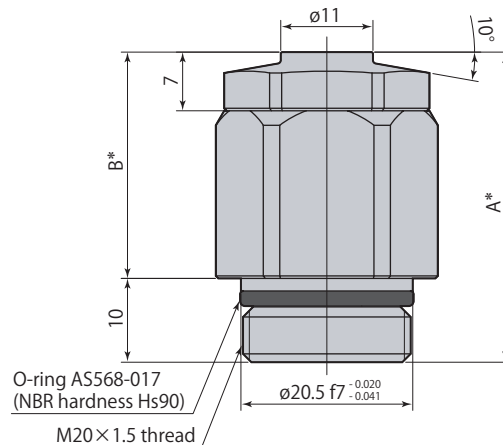
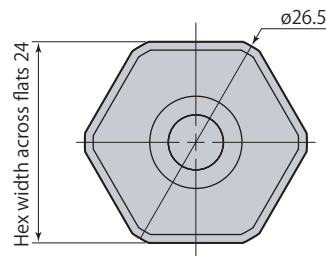

* : Dimension varies according to the size and model no of the coupler.

WVP-2BPH-□□ Hydraulic pressure 25 MPa & air plug Recommended tightening torque: 25 N·m

mm

Coupler	Socket	WVP-2BSH					
	Plug	WVP-2BPH-03T	WVP-2BPH-06T	WVP-2BPH-10T	WVP-2BPH-16T	WVP-2BPH-25T	WVP-2BPH-40T
A		16	17	19	22	26	32
B		6	7	9	12	16	22
H (distance to pallets)		11.5	12.5	14.5	17.5	21.5	27.5
Coupler mass	Socket	38 g					
	Plug	34 g	37 g	42 g	49 g	58 g	73 g

Applicable pallet clamp / locate ring

Pallet clamp	CPC-, CPH-	□03H	□06H	□10H	-	□16H	-	□25H	-	□40H	-
Air pallet clamp	CPY-	□02H, □03H	-	-	□04H	-	□06H	-	□10H	-	□06H
Locate ring	CPS-	□03T, D	□06T, D	□10T, D	□03T, D	□16T, D	□06T, D	□25T, D	□10T, D	□40T, D	□06F
Locate ring shim		S03T, D	S06T, D	S10T, D	S03T, D	S16T, D	S06T, D	S25T, D	S10T, D	S40T, D	-

mm

Coupler	Socket	WVP-2BSH						
	Plug	WVP-2BPH-03F	WVP-2BPH-06F	WVP-2BPH-10F	WVP-2BPH-10A	WVP-2BPH-16F	WVP-2BPH-25F	WVP-2BPH-40F
A		25.5	27	31	38	37	44.5	55.5
B		15.5	17	21	28	27	34.5	45.5
H (distance to pallets)		21	22.5	26.5	33.5	32.5	40	51
Coupler mass	Socket	38 g						
	Plug	57 g	61 g	71 g	95 g	92 g	114 g	147 g

Applicable pallet clamp / locate ring

Pallet clamp	CPC-, CPH-	□03H	□06H	□03H	□10H	-	□16H	□25H	□40H
Air pallet clamp	CPY-	□02H, □03H	-	□02H, □03H	-	□10H	-	-	-
Locate ring	CPS-	□03F	□06F	□03F	□10F	□10F	□16F	□25F	□40F
Locate ring shim		-	-	S03F	-	-	-	-	-

mm

Coupler	Socket	WVP-2BSH							
	Plug	WVP-2BPH-03B	WVP-2BPH-06S	WVP-2BPH-06B	WVP-2BPH-10S	WVP-2BPH-16S	WVP-2BPH-25S	WVP-2BPH-40S	
A		30	28.5	33.5	33	40	47.5	58.5	
B		20	18.5	23.5	23	30	37.5	48.5	
H (distance to pallets)		25.5	24	29	28.5	35.5	43	54	
Coupler mass	Socket	38 g							
	Plug	68 g	65 g	77 g	75 g	101 g	123 g	156 g	

Applicable pallet clamp / locate ring

Pallet clamp	CPC-, CPH-	-	□06H	-	-	□10H	□16H	-	□25H	□40H
Air pallet clamp	CPY-	□04H	-	□04H	□06H	-	-	□10H	-	-
Locate ring	CPS-	□03F	□06F	□03F	□06F	□10F	□16F	□10F	□25F	□40F
Locate ring shim		S03F	S06F	-	S06F	S10F	S16F	S10F	S25F	S40F

■ indicates made to order.

Caution in use

- The distance between the base and the pallet varies when the pallet clamp is mounted with the shim (model CPC-S, CPH-S, CPY-S). Install the Pal coupler to have the dimension $H_{-0.05}^{+0.05}$ set as shown in the above table when it is connected.
- Former pallet clamp (model CPC-□□F, CPH-□□F) cannot be used in combination with the couplers, as lift stroke is different.
- Ask Pascal in case it is used in combination with Pal coupling model CPM.
- Provide the stopper and the guide as shown in the diagram to protect coupler from damage unless it is used in combination with pallet clamp. Do not use a coupler as a guide or stopper when connecting. It may cause the damage. Install the stopper to have the dimension $H_{-0.05}^{+0.05}$ set as shown in the above table (See diagram on the right). Observe allowable eccentricity and inclination value when installing the guide. (Refer to **page →78** for details on allowable eccentricity and inclination value.)

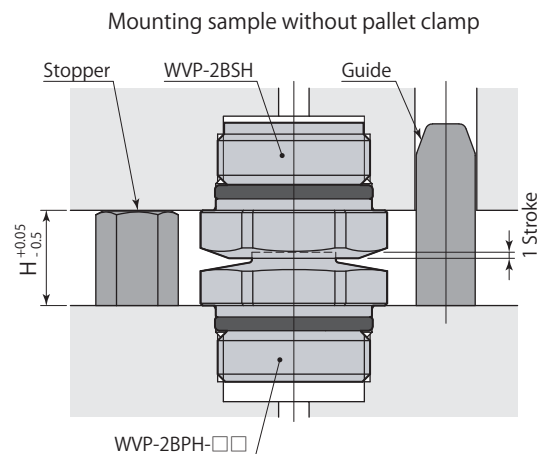

Dimensions

WVP-3DSN

Blow air & coolant socket
Recommended tightening torque : 30 N·m

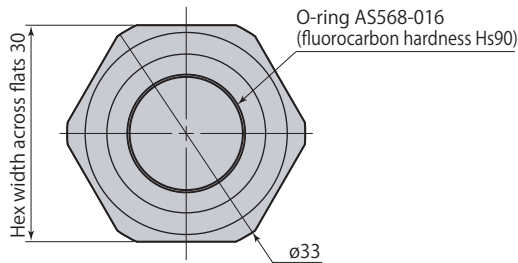
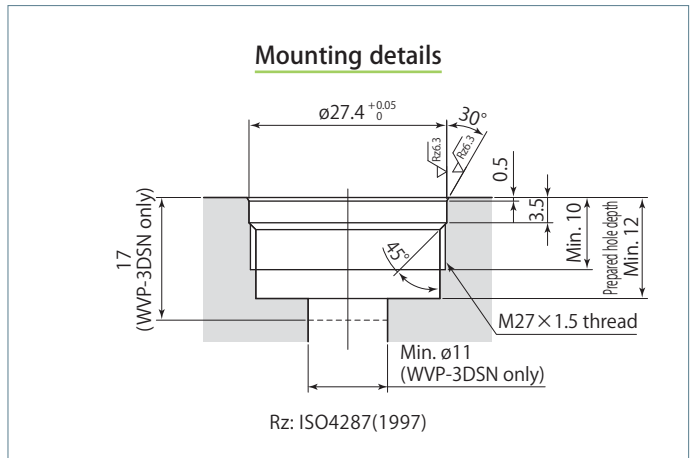
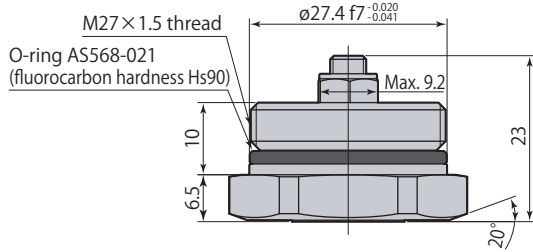

- Fluid leaks from the tip of coupler when supplying it under disconnected state.
- Stop supplying fluid during disconnection and connection operations. Disconnecting or connecting coupler while fluid is flowing results in the leakage.
- Coupler has no built in filter. Ensure that foreign substances on connecting surfaces are removed by blowing air before connecting to prevent intrusion of foreign substances into piping.

WVP-3DPN-10A, 16F, 25F, 40F
WVP-3DPN-16S, 25S, 40S only

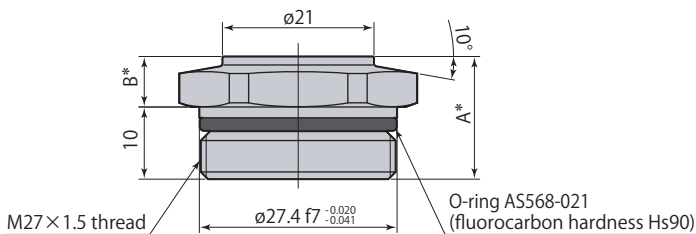
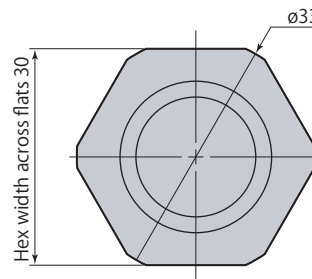
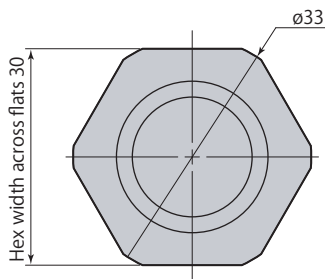

O-ring AS568-021 (fluorocarbon hardness Hs90)

M27 x 1.5 thread

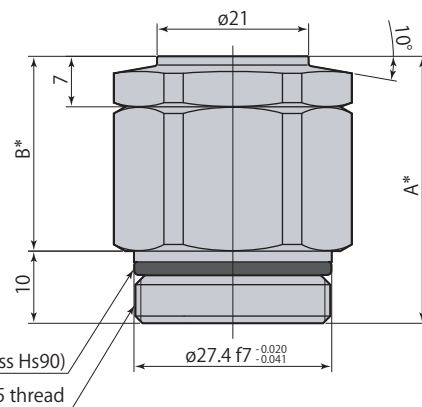

* : Dimension varies according to the size and model no of the coupler.

WVP-3DPN-□□ Blow air & coolant plug Recommended tightening torque : 30 N·m

WVP-3D□N	Pal coupler Air & coolant	1MPa
-----------------	--------------------------------------	-------------

mm

Coupler	Socket	WVP-3DSN					
	Plug	WVP-3DPN-03T	WVP-3DPN-06T	WVP-3DPN-10T	WVP-3DPN-16T	WVP-3DPN-25T	WVP-3DPN-40T
A		16	17	19	22	26	32
B		6	7	9	12	16	22
H (distance to pallets)		11.5	12.5	14.5	17.5	21.5	27.5
Coupler mass	Socket	70 g					
	Plug	57 g	60 g	67 g	77 g	90 g	111 g

Applicable pallet clamp / locate ring

Pallet clamp	CPC-, CPH-	□03H	□06H	□10H	-	□16H	-	□25H	-	□40H	-
Air pallet clamp	CPY-	□02H, □03H	-	-	□04H	-	□06H	-	□10H	-	□06H
Locate ring	CPS-	□03T, D	□06T, D	□10T, D	□03T, D	□16T, D	□06T, D	□25T, D	□10T, D	□40T, D	□06F
Locate ring shim		S03T, D	S06T, D	S10T, D	S03T, D	S16T, D	S06T, D	S25T, D	S10T, D	S40T, D	-

mm

Coupler	Socket	WVP-3DSN						
	Plug	WVP-3DPN-03F	WVP-3DPN-06F	WVP-3DPN-10F	WVP-3DPN-10A	WVP-3DPN-16F	WVP-3DPN-25F	WVP-3DPN-40F
A		25.5	27	31	38	37	44.5	55.5
B		15.5	17	21	28	27	34.5	45.5
H (distance to pallets)		21	22.5	26.5	33.5	32.5	40	51
Coupler mass	Socket	70 g						
	Plug	89 g	94 g	108 g	132 g	128 g	157 g	197 g

Applicable pallet clamp / locate ring

Pallet clamp	CPC-, CPH-	□03H	□06H	□03H	□10H	-	□16H	□25H	□40H
Air pallet clamp	CPY-	□02H, □03H	-	□02H, □03H	-	□10H	-	-	-
Locate ring	CPS-	□03F	□06F	□03F	□10F	□10F	□16F	□25F	□40F
Locate ring shim		-	-	S03F	-	-	-	-	-

mm

Coupler	Socket	WVP-3DSN						
	Plug	WVP-3DPN-03B	WVP-3DPN-06S	WVP-3DPN-06B	WVP-3DPN-10S	WVP-3DPN-16S	WVP-3DPN-25S	WVP-3DPN-40S
A		30	28.5	33.5	33	40	47.5	58.5
B		20	18.5	23.5	23	30	37.5	48.5
H (distance to pallets)		25.5	24	29	28.5	35.5	43	54
Coupler mass	Socket	70 g						
	Plug	104 g	99 g	116 g	114 g	139 g	168 g	208 g

Applicable pallet clamp / locate ring

Pallet clamp	CPC-, CPH-	-	□06H	-	-	□10H	□16H	-	□25H	□40H
Air pallet clamp	CPY-	□04H	-	□04H	□06H	-	-	□10H	-	-
Locate ring	CPS-	□03F	□06F	□03F	□06F	□10F	□16F	□10F	□25F	□40F
Locate ring shim		S03F	S06F	-	S06F	S10F	S16F	S10F	S25F	S40F

Caution in use

- The distance between the base and the pallet varies when the pallet clamp is mounted with the shim (model CPC-S, CPH-S, CPY-S). Install the Pal coupler to have the dimension $H_{-0.05}^{+0.05}$ set as shown in the above table when it is connected.
- Former pallet clamp (model CPC-□□F, CPH-□□F) cannot be used in combination with the couplers, as lift stroke is different.
- Ask Pascal in case it is used in combination with Pal coupling model CPM.
- Provide the stopper and the guide as shown in the diagram to protect coupler from damage unless it is used in combination with pallet clamp. Do not use a coupler as a guide or stopper when connecting. It may cause the damage. Install the stopper to have the dimension $H_{-0.05}^{+0.05}$ set as shown in the above table (See diagram on the right). Observe allowable eccentricity and inclination value when installing the guide. (Refer to **page →79** for details on allowable eccentricity and inclination value.)

■ indicates made to order.

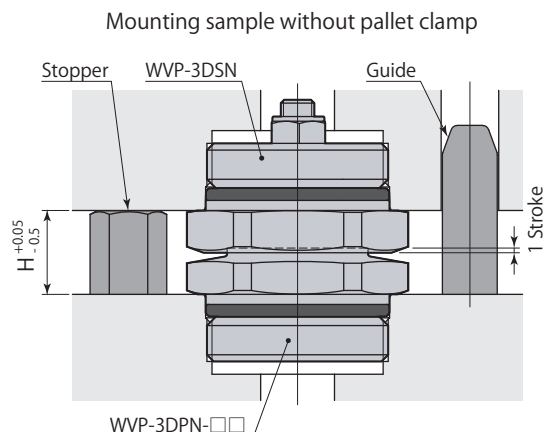

Hydraulic and air coupler with zero hydraulic oil leak with special seal at tip section

Pal coupler socket
Hydraulic pressure 7 MPa & air
model **WVP-2FSL**



Pal coupler plug
Hydraulic pressure 7 MPa & air
model **WVP-2FPL**

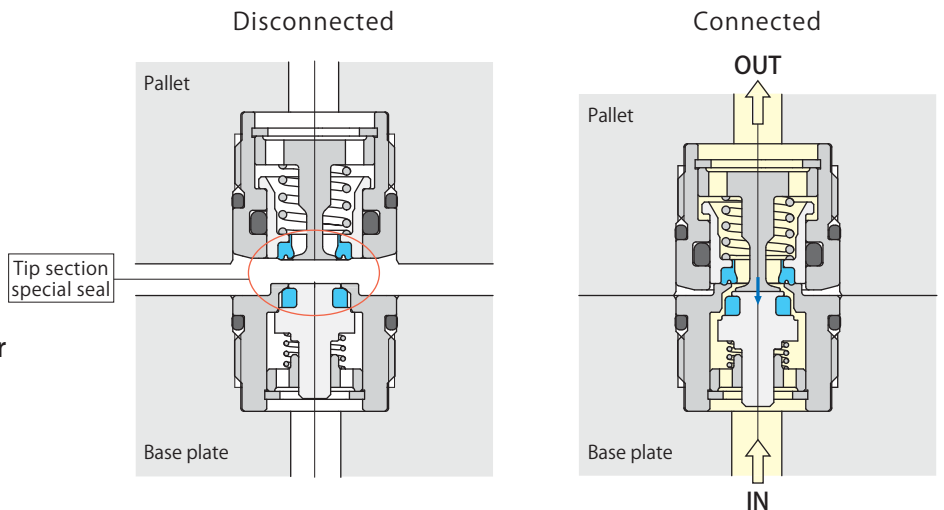
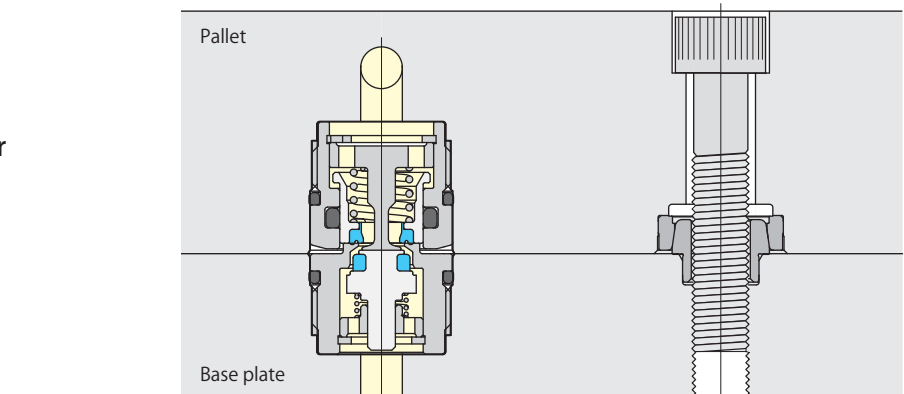

Specifications

- Special soft seal at tip section enables plug (WVP-2FPL) to be pressurized under disconnected state. Socket (WVP-2FSL) can retain residual pressure of up to 0.3 MPa.
- Special seal installed on the tip of coupler socket and coupler plug can minimize the intrusion of air and spill of working fluid during connection and disconnection, furthermore, it prevents corruption of coolant by being miscible with spilled working fluid and air contamination of clamp circuit.
- Height of coupler is maintained low in order to reduce thickness of pallet.
- This model is designed to use on flat mating faces with no protrusion from mount face.
- The parts in the coupler are corrosion prevented (plating or stainless) and oil and air can be applied as a fluid.

Pressure range	0–7 MPa	Circuit symbol
Proof pressure	10.5 MPa	
Orifice area	10.2 mm ²	
Fluid used	General mineral based hydraulic oil (ISO-VG32 equivalent) & air	
Allowable eccentricity	±0.5 mm	
Allowable inclination	0.3° or less	
Reactive force*	113 N per 1 MPa fluid pressure	
	Max. spring force for no pressure 40 N	
Operating temperature	0–70 °C	
Mass	WVP-2FSL : 31 g WVP-2FPL : 29 g	

* : Reactive force (N) = Fluid pressure (MPa) × 113 + 40

WVP-2FSL

Hydraulic pressure 7 MPa & air socket
Recommended tightening torque : 15 N·m

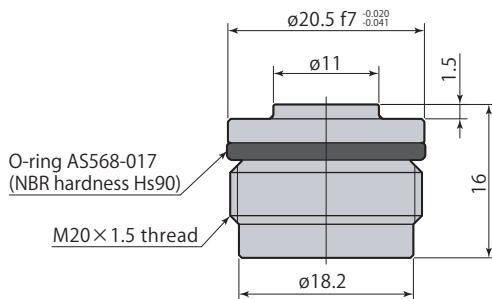
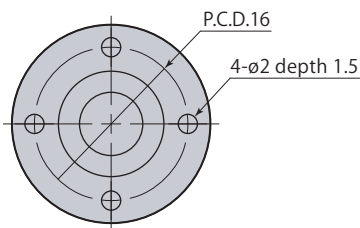
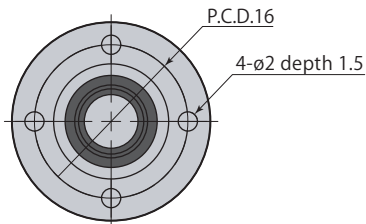
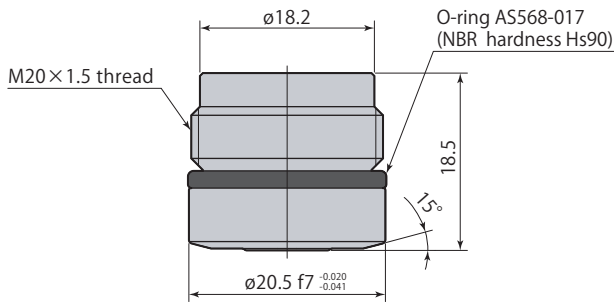

WVP-2FPL

Hydraulic pressure 7 MPa & air plug
Recommended tightening torque : 15 N·m

Dimensions

Mounting details

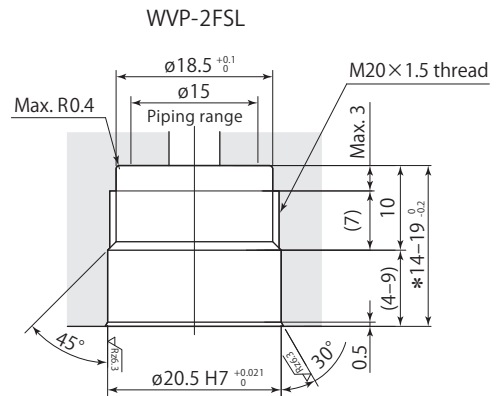

* :When using Pal fix as a set, be sure to set depth to 19_{-0.2}⁰. Refer to pages →64-75 for details on Pal fix.

Mounting details

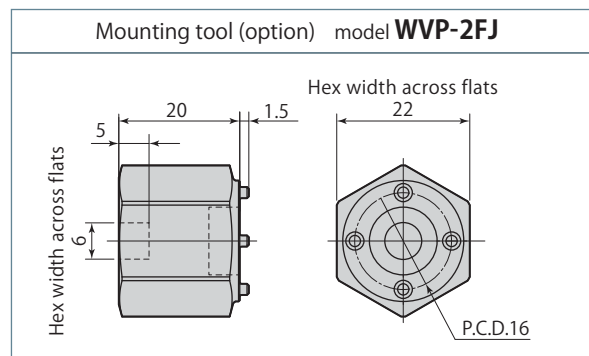
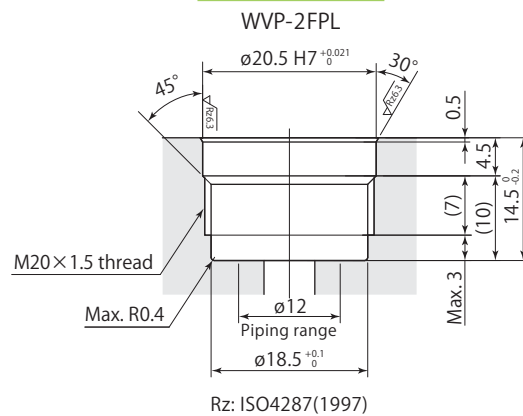

Caution in use

- Stop supplying fluid during disconnection and connection operations. Disconnecting or connecting coupler while fluid is flowing results in the leakage.
- Coupler has no built in filter. Ensure that foreign substances on connecting surfaces are removed by blowing air before connecting to prevent intrusion of foreign substances into piping.
- Make sure air bleeding in the hydraulic circuit is perfectly done when installation.
- Provide the stopper and the guide as shown in the diagram to protect coupler from damage unless it is used in combination with Pal fix. Do not use a coupler as a guide or stopper when connecting. It may cause the damage. Install the stopper to have the dimension 33.5_{-0.5}⁰ (See diagram on the right). Observe allowable eccentricity and inclination value when installing the guide. (Refer to page →84 for details on allowable eccentricity and inclination value.)

Mounting sample without Pal fix

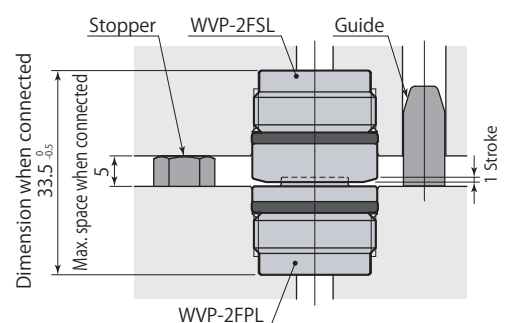

Air & coolant coupler with large orifice area and capability to accommodate large flow rates.

Pal coupler socket
Blow air & coolant
model **WVP-3GSN**



Pal coupler plug
Blow air & coolant
model **WVP-3GPN**

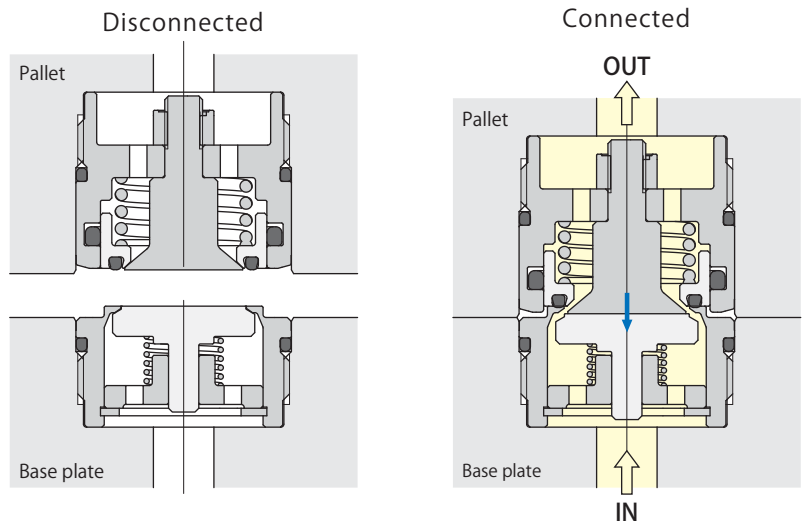
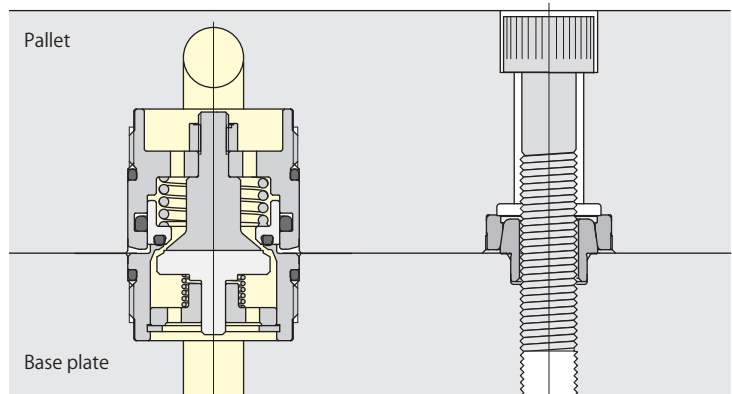

Specifications

- Large orifice area allows to supply large volume of coolant or blow air.
- Height of coupler is maintained low in order to reduce thickness of pallet.
- This model is designed to use on flat mating faces with no protrusion from mount face.

Pressure range	0–1 MPa	Circuit symbol Air & coolant Connect/disconnect under pressure : Incapable
Proof pressure	1.5 MPa	
Orifice area	29.0 mm ²	
Fluid used	Air & coolant	
Allowable eccentricity	±0.5 mm	
Allowable inclination	0.3° or less	
Reactive force*	380 N per 1 MPa fluid pressure	
	Max. spring force for no pressure 60 N	
Operating temperature	0–70 °C	
Mass	WVP-3GSN : 77 g WVP-3GPN : 48 g	

* : Reactive force (N) = Fluid pressure (MPa) × 380 + 60

Dimensions

WVP-3GSN

Blow air & coolant socket
Recommended tightening torque : 30 N·m

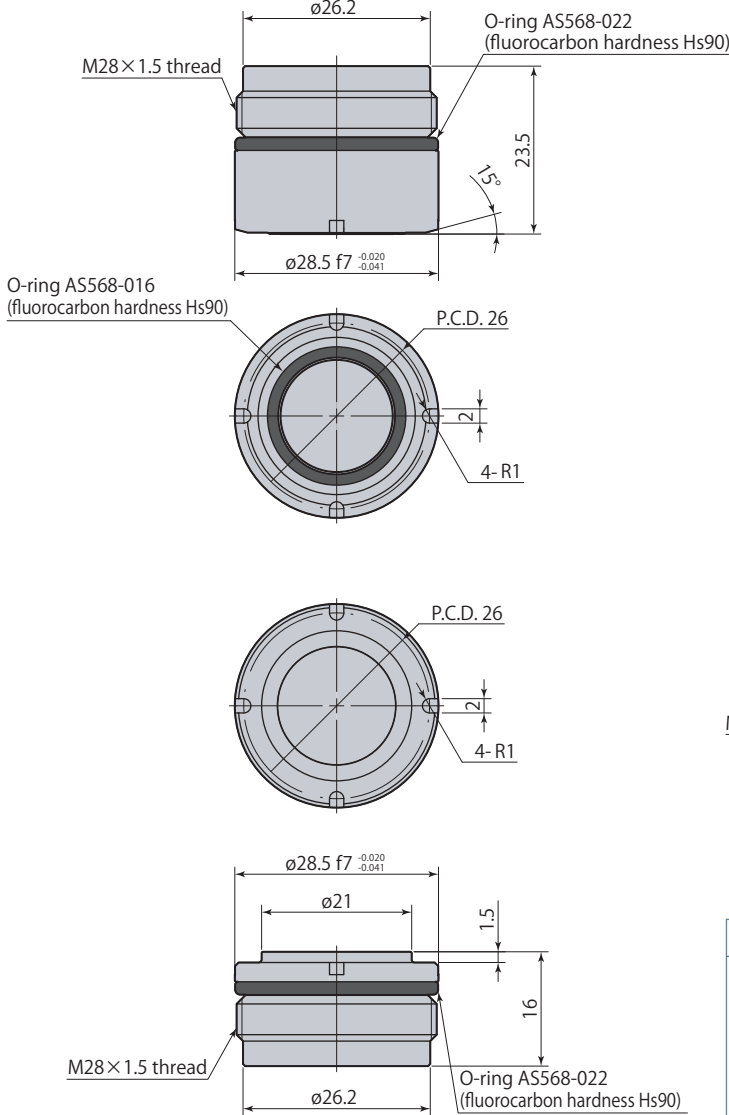

WVP-3GPN

Blow air & coolant plug
Recommended tightening torque : 30 N·m

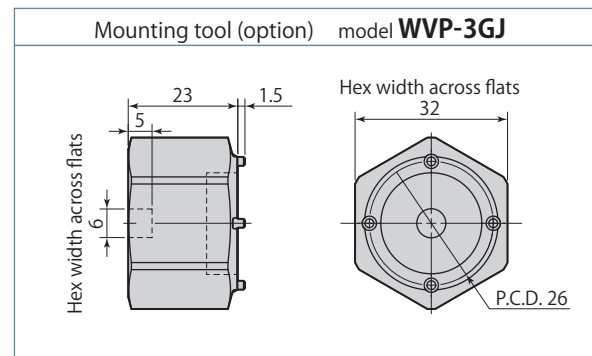
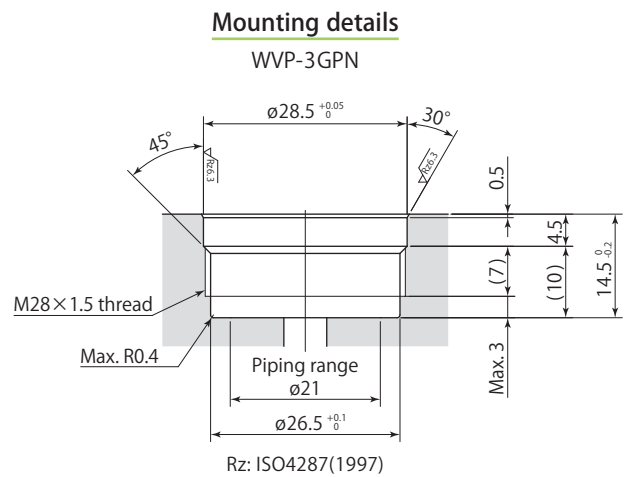
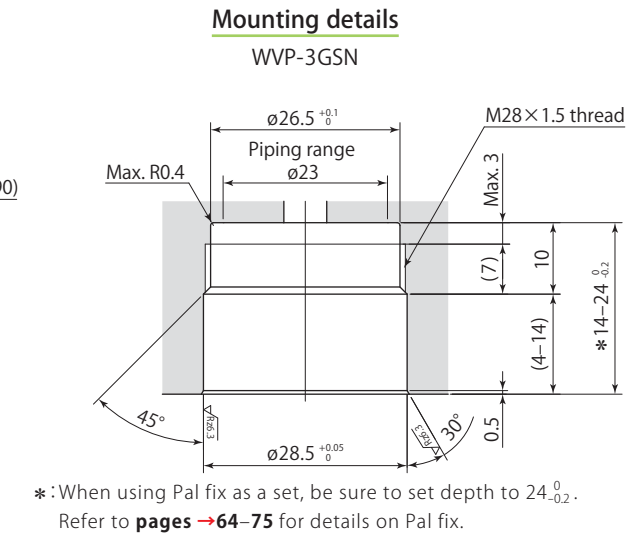

Caution in use

- Fluid leaks from the tip of coupler when supplying it under disconnected state.
- Stop supplying fluid during disconnection and connection operations. Disconnecting or connecting coupler while fluid is flowing results in the leakage.
- Coupler has no built in filter. Ensure that foreign substances on connecting surfaces are removed by blowing air before connecting to prevent intrusion of foreign substances into piping.
- Provide the stopper and the guide as shown in the diagram to protect coupler from damage unless it is used in combination with Pal fix. Do not use a coupler as a guide or stopper when connecting. It may cause the damage. Install the stopper to have the dimension 38.5_{0.5} (See diagram on the right). Observe allowable eccentricity and inclination value when installing the guide. (Refer to page →86 for details on allowable eccentricity and inclination value.)

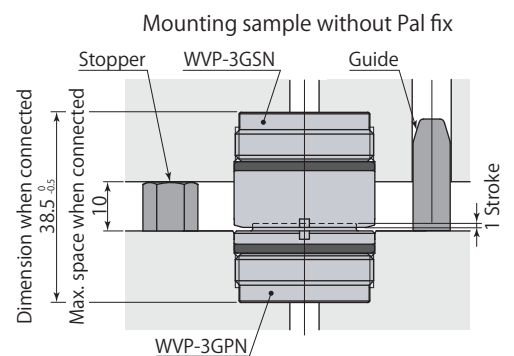

Downsized air coupler but maintaining same flow rate with existing models.

Pal coupler socket
Air
model **WVP-1FSN**



Pal coupler plug
Air
model **WVP-1FPN**

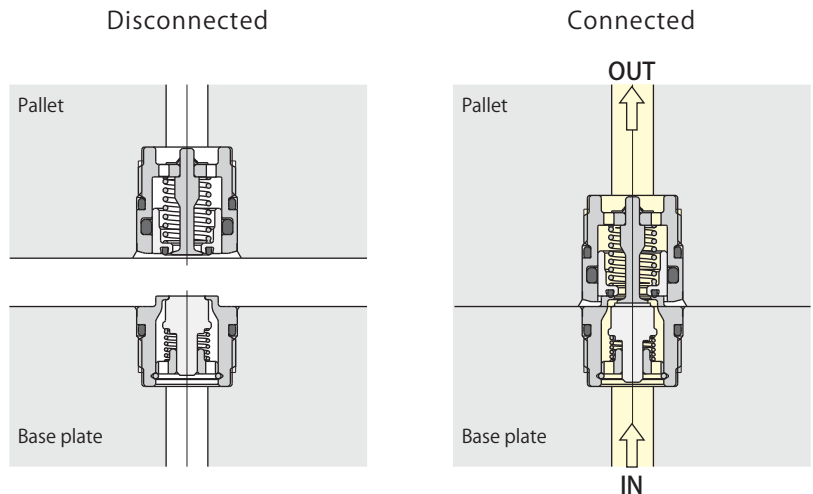
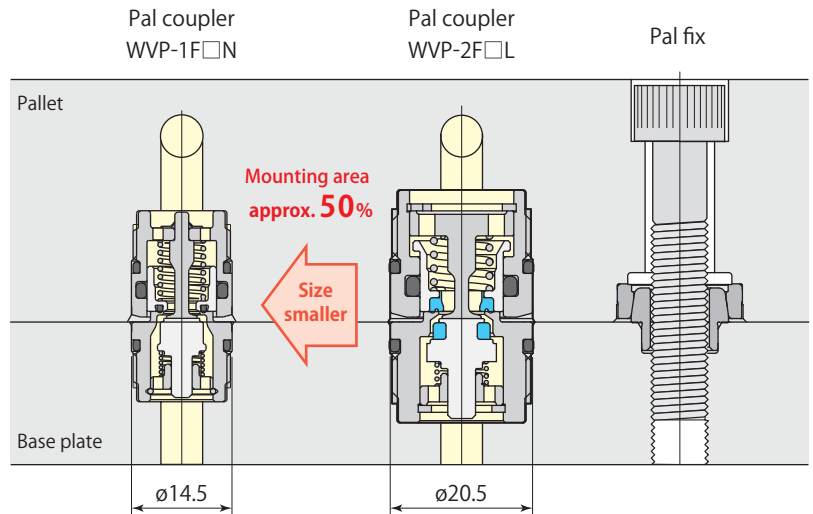

Specifications

- This model is designed to use on flat mating faces with no protrusion from mount face.
- The parts in the coupler are corrosion prevented (stainless).

Pressure range	0–1 MPa	Circuit symbol Air Connect/disconnect under pressure : Incapable
Proof pressure	1.5 MPa	
Orifice area	8 mm ²	
Fluid used	Air	
Allowable eccentricity	±0.4 mm	
Allowable inclination	0.3° or less	
Reactive force*	79 N per 1 MPa fluid pressure Max. spring force for no pressure 24 N	
Operating temperature	0–70 °C	
Mass	WVP-1FSN : 12.5 g WVP-1FPN : 10.5 g	

* : Reactive force (N) = Fluid pressure (MPa) × 79 + 24

WVP-1FSN

Air socket

Recommended tightening torque : 5 N·m

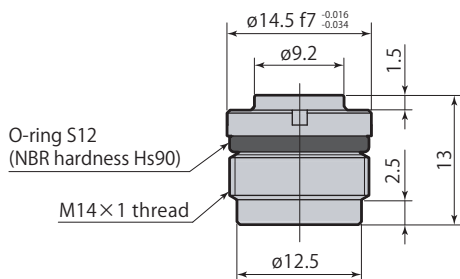
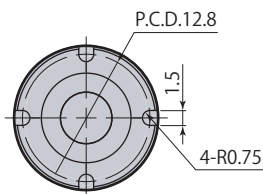
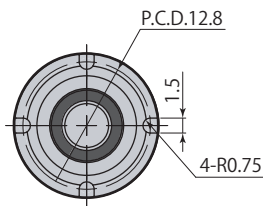
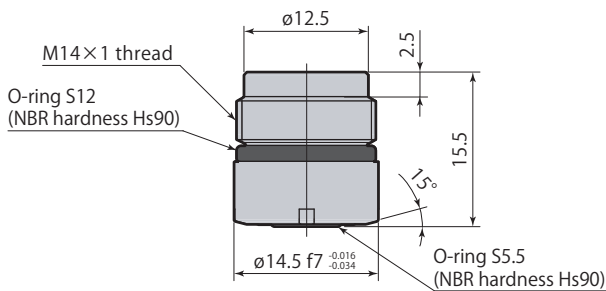

WVP-1FPN

Air plug

Recommended tightening torque : 5 N·m

Dimensions

Mounting details

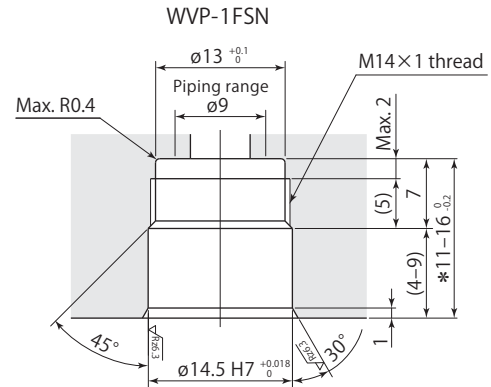

*: When using Pal fix as a set, be sure to set depth to 16_{-0.2}⁰. Refer to pages →64-75 for details on Pal fix.

Mounting details

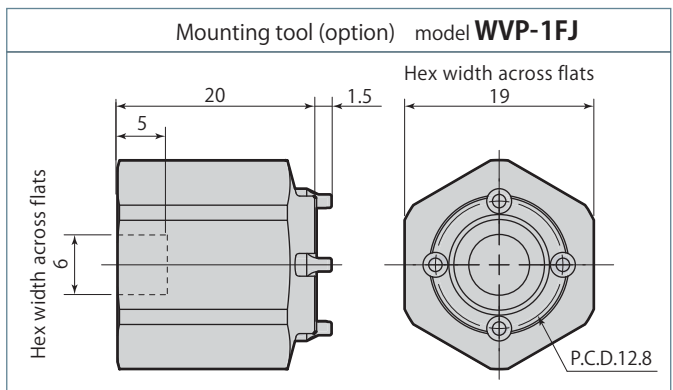
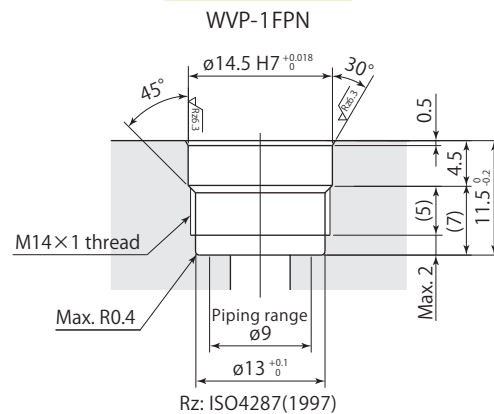

Caution in use

- Stop supplying fluid during disconnection and connection operations. Disconnecting or connecting coupler while fluid is flowing results in the leakage.
- Coupler has no built in filter. Ensure that foreign substances on connecting surfaces are removed by blowing air before connecting to prevent intrusion of foreign substances into piping.
- Provide the stopper and the guide as shown in the diagram to protect coupler from damage unless it is used in combination with Pal fix. Do not use a coupler as a guide or stopper when connecting. It may cause the damage. Install the stopper to have the dimension 27.5_{-0.5}⁰ (See diagram on the right). Observe allowable eccentricity and inclination value when installing the guide. (Refer to page →88 for details on allowable eccentricity and inclination value.)

Mounting sample without Pal fix

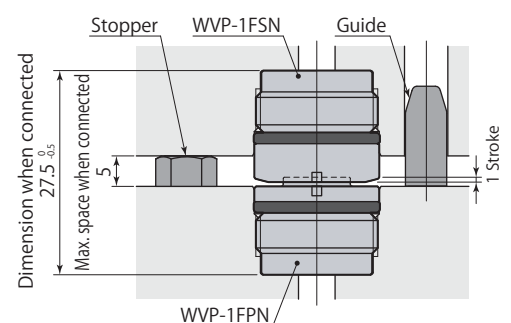

Special seal mechanism ensures leak of operating oil is zero for connecting and disconnecting

7 MPa Non-leak coupler socket

model **WVP-2HSL**

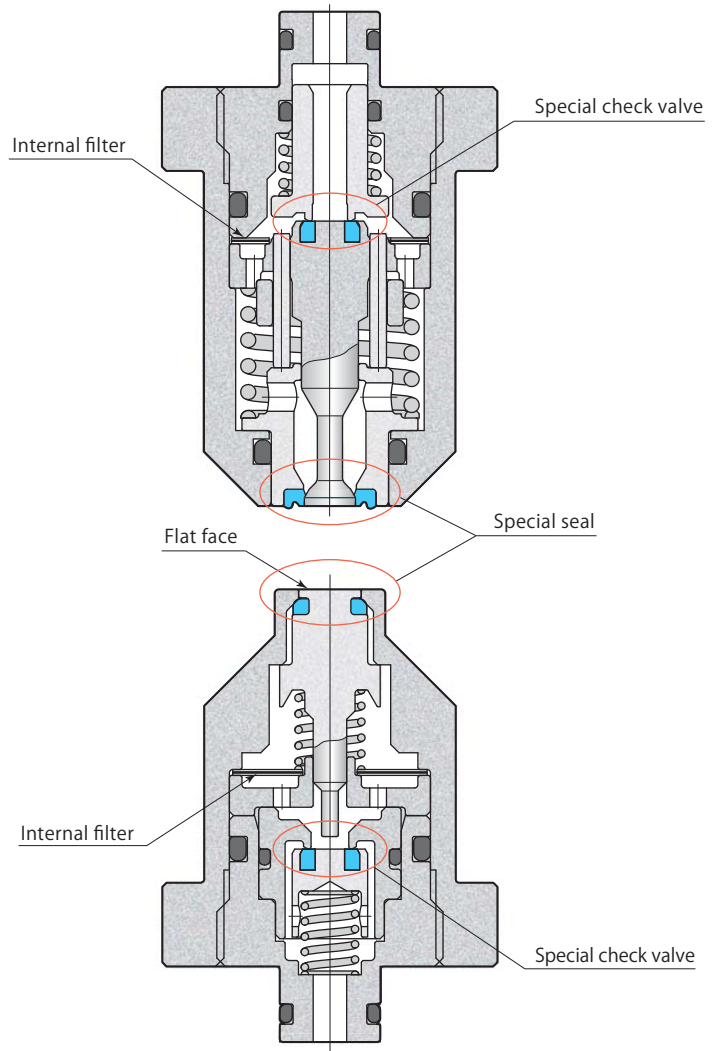

7 MPa Non-leak coupler plug

model **WVP-2HPL**

Spill amount (liquid drip amount per connection or disconnection) 0.01 mL or less

Specifications

- Special seal installed on the tip of coupler socket and coupler plug can minimize the intrusion of air and spill of working fluid during connection and disconnection, furthermore, it prevents corruption of coolant by being miscible with spilled working fluid and air contamination of clamp circuit.
- Model WVP-2H incorporates filter and protects internal check valves and clamps from foreign substances.
- Connection and disconnection, which had been difficult to perform with conventional couplers while hydraulic pressure is applied, can be performed smoothly.
- Pressure in the circuit is retained for a long time after disconnection of coupler.

Pressure range	1–7 MPa	Circuit symbol Plug hydraulic pressure source 7MPa Connect/disconnect: Capable under pressure
Proof pressure	10.5 MPa	
Orifice area	12.5 mm ²	
Fluid used	General mineral based hydraulic oil (ISO-VG32 equivalent)	
Allowable eccentricity	±0.4 mm	
Allowable inclination	0.2° or less	
Reactive force*	154 N per 1 MPa fluid pressure	
	Max. spring force for no pressure 157 N	
Operating temperature	0–70 °C	
Mass	WVP-2HSL : 270 g	WVP-2HPL, 2HDL : 230 g

*: Reactive force (N) = Fluid pressure (MPa) × 154 + 157

- Supply operating oil from plug.
- Mixed use with model WVP-2S□L is not possible.

Non-leak coupler fixed

Coupler lower section hydraulic pressure supply

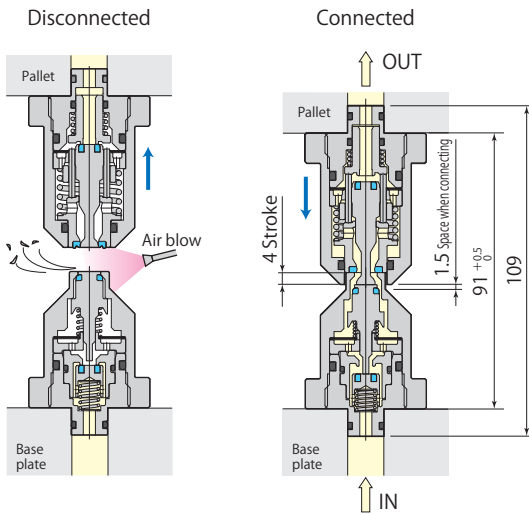

Non-leak coupler float

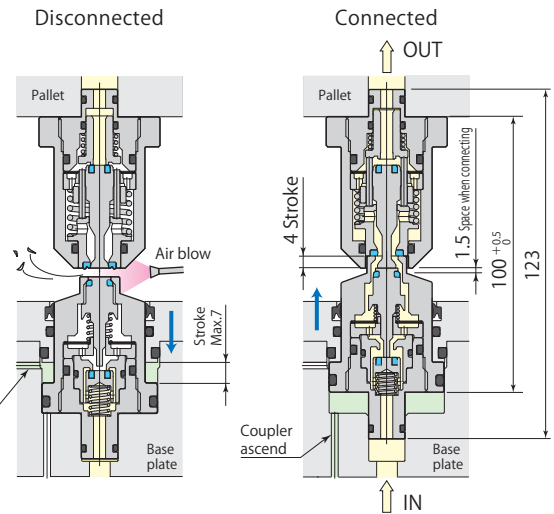

WVP-2HSL socket (fixed)

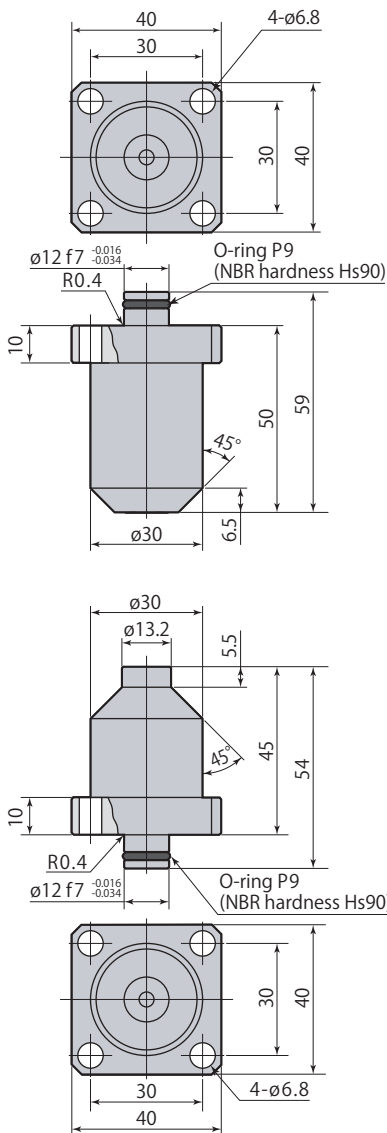

WVP-2HPL plug (fixed)

Dimensions

Mounting details

WVP-2HSL
WVP-2HPL

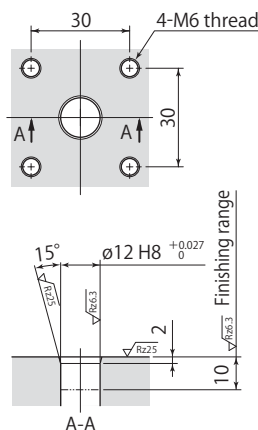

WVP-2HDL plug (floating)

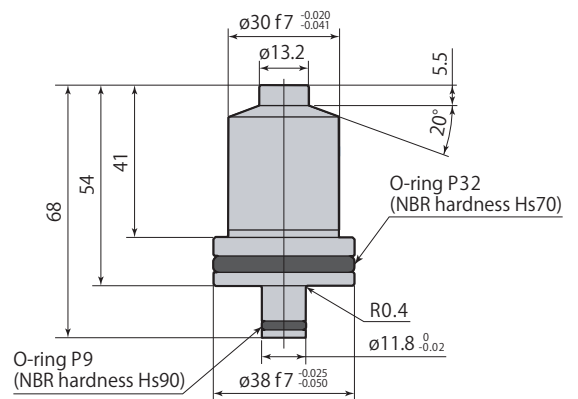

Mounting details

WVP-2HDL

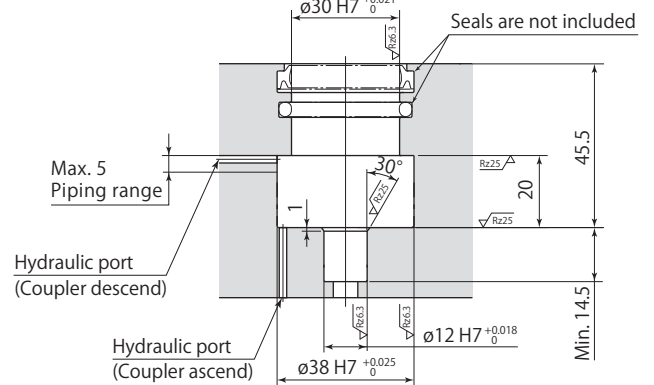

● Mounting screws are not included.

Rz: ISO4287(1997)

Special seal mechanism ensures leak of operating oil is zero for connecting and disconnecting

7 MPa Non-leak coupler socket

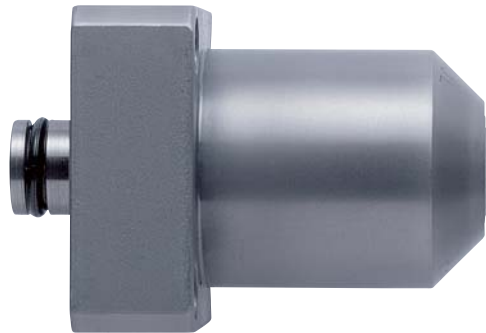
model **WVP-2SSL**

7 MPa Non-leak coupler plug

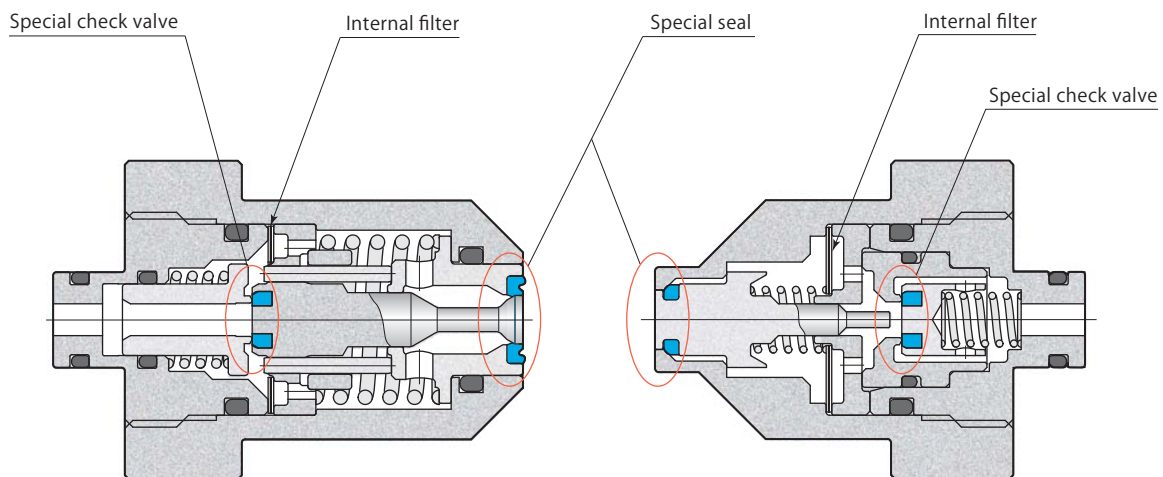
model **WVP-2SPL**

Spill amount (liquid drip amount per connection or disconnection) 0.01 mL or less

Specifications

- Special seal installed on the tip of coupler socket and coupler plug can minimize the intrusion of air and spill of working fluid during connection and disconnection, furthermore, it prevents corruption of coolant by being miscible with spilled working fluid and air contamination of clamp circuit.
- Model WVP-2S incorporates filter and protects internal check valves and clamps from foreign substances.
- Connection and disconnection, which had been difficult to perform with conventional couplers while hydraulic pressure is applied, can be performed smoothly.
- Pressure in the circuit is retained for a long time after disconnection of coupler.
- Jig pallet fabrication cost is kept low by using an economically priced plug for coupler of pallet.

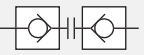
Pressure range	1–7 MPa	Circuit symbol 
Proof pressure	10.5 MPa	
Orifice area	12.5 mm ²	
Fluid used	General mineral based hydraulic oil (ISO-VG32 equivalent)	Socket hydraulic pressure source 7MPa Connect/disconnect: Capable under pressure
Allowable eccentricity	±0.4 mm	
Allowable inclination	0.2° or less	
Reactive force*	154 N per 1 MPa fluid pressure	
	Max. spring force for no pressure 162 N	
Operating temperature	0–70 °C	
Mass	WVP-2SSL : 300 g	WVP-2SPL : 260 g

* : Reactive force (N) = Fluid pressure (MPa) × 154 + 162

- Supply operating oil from socket.
- Mixed use with model WVP-2H□L is not possible.

Non-leak coupler fixed

Horizontal mounting of coupler

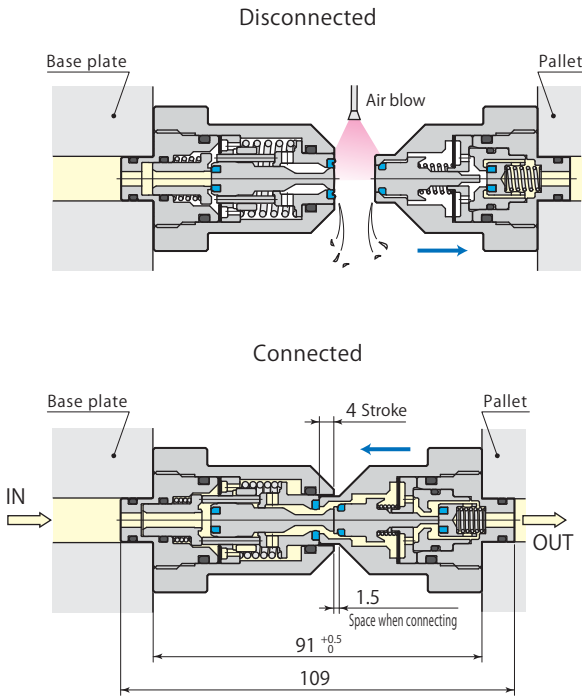

Dimensions

WVP-2SSL socket (fixed)

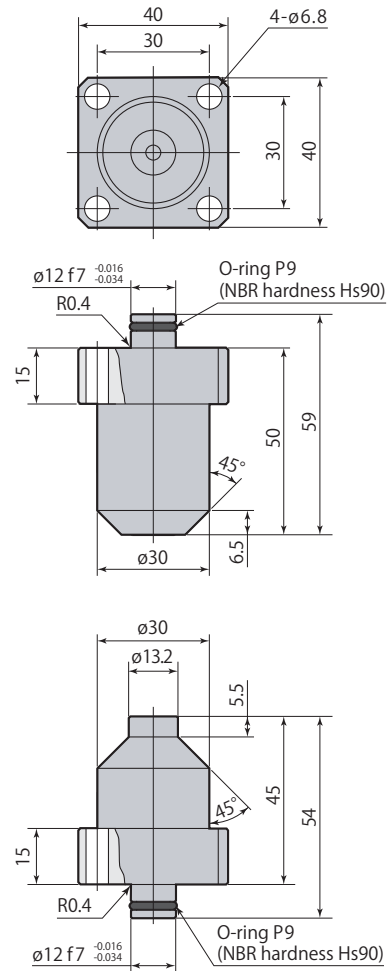

Non-leak coupler fixed

Coupler upper section hydraulic pressure supply

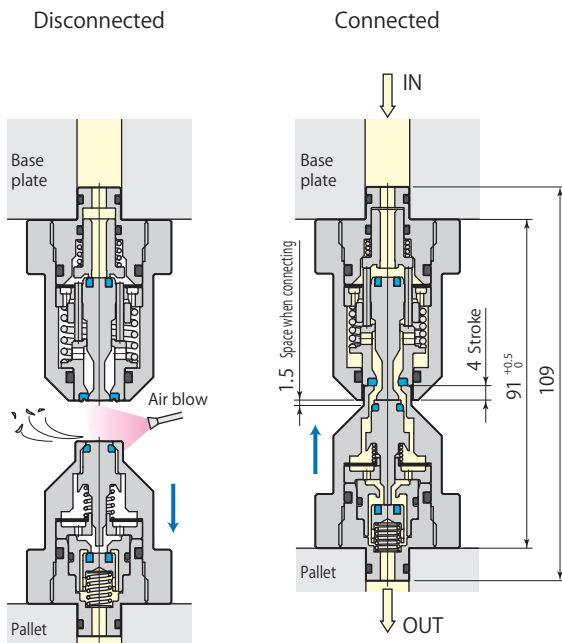

WVP-2SPL plug (fixed)

● Mounting screws are not included.

Mounting details

WVP-2SSL, WVP-2SPL

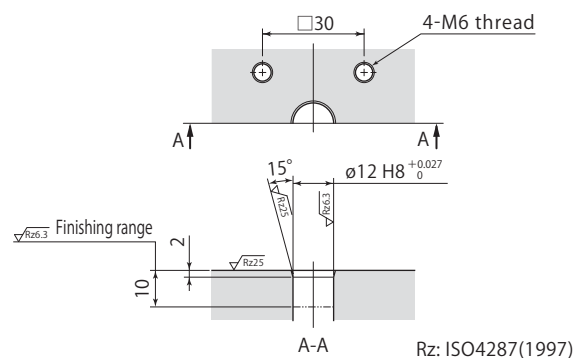

● Perform installation with plug below so metal chips are less likely to adhere and air blowing can be performed properly.

Compact coupler that has less reactive force when connecting by means of a pilot check valve

7 MPa Pilot coupler plug

model **WVP-2EPL**

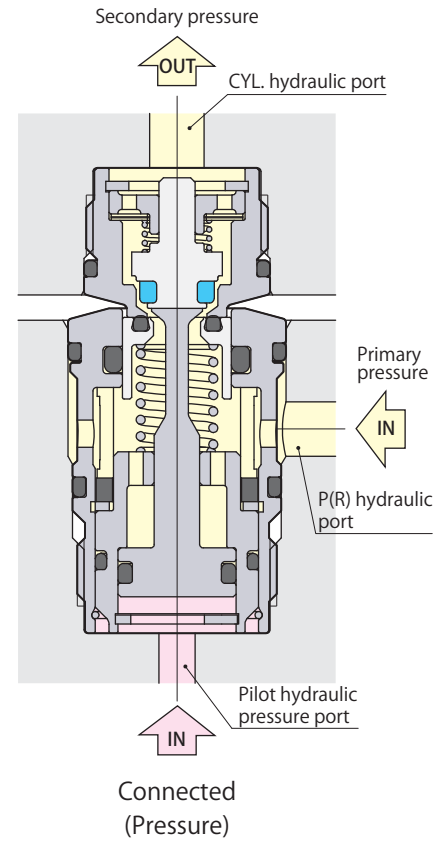
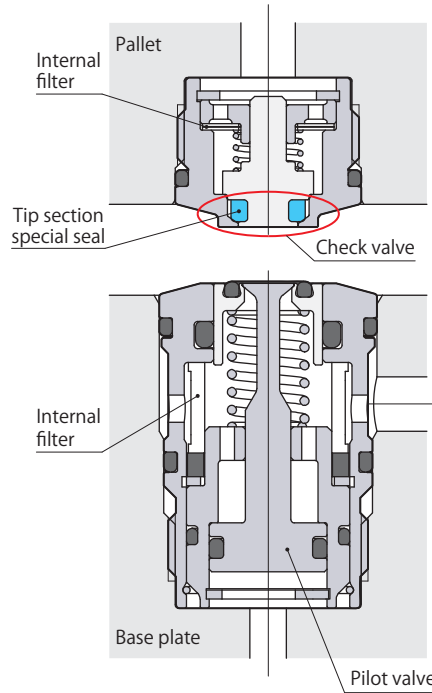

7 MPa Pilot coupler socket

model **WVP-2ESL**

Disconnected

Connected (Pressure)

Specifications

- A pilot check mechanism enables the reactive force when connecting to lower.

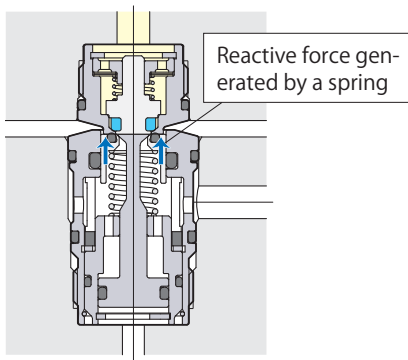

- Unique seal on the tip of coupler ensures a long-term retaining the circuit pressure even after disconnection.
- Filter is fitted inside coupler to prevent intrusion of metal chips and debris into hydraulic circuit.

Pressure range	1–7 MPa	Circuit symbol OIL 7MPa Secondary pressure retainable
Proof pressure	10.5 MPa	
Orifice area	10.2 mm ²	
Fluid used	General mineral based hydraulic oil (ISO-VG32 equivalent)	
Allowable eccentricity	±0.5 mm	
Allowable inclination	0.3° or less	
Reactive force	Spring force when connected 28 N	
	Reactive force when pressurized $113 \times P^{*1} + 36$ N	
Pilot pressure	$0.4 \times P^{*2} + 0.1$ MPa or more	
Operating temperature	0–70 °C	
Mass	WVP-2EPL : 29 g WVP-2ESL : 82 g	

* 1 : P = Primary side hydraulic pressure (MPa)

* 2 : P = Secondary side hydraulic pressure (MPa)

WVP-2EPL

Hydraulic pressure 7MPa plug
Recommended tightening torque : 15 N·m

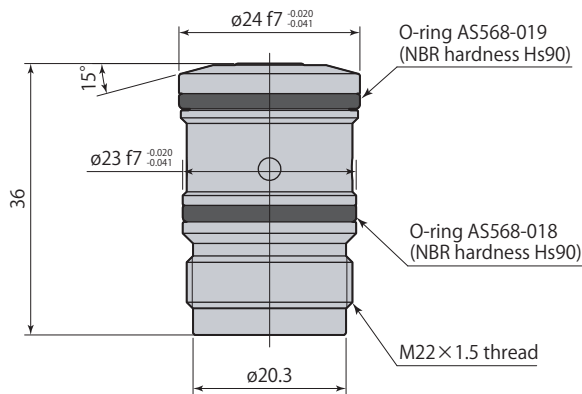
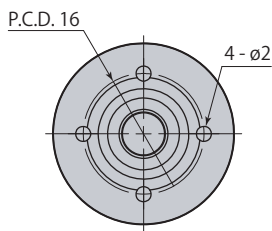
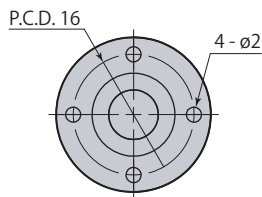
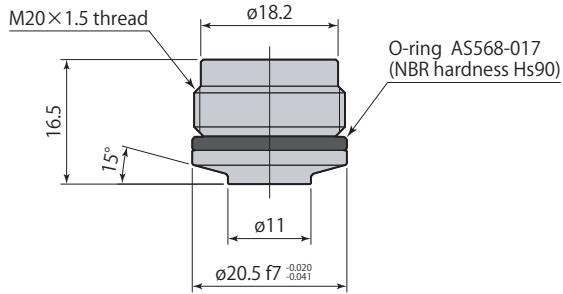

WVP-2ESL

Hydraulic pressure 7MPa socket
Recommended tightening torque : 15 N·m

Dimensions

Mounting details

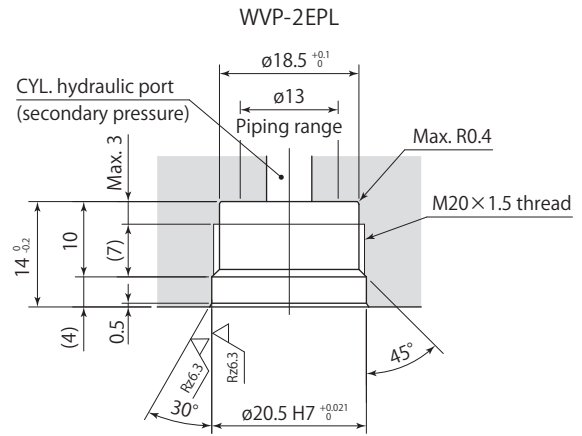

Mounting details

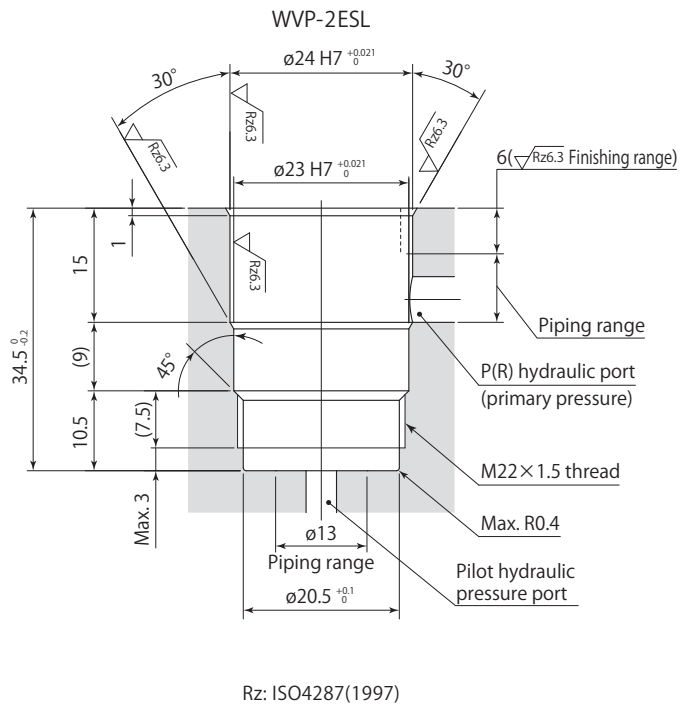

Rz: ISO4287(1997)

- Do not supply pressure to P port (primary) and pilot port under disconnected state or during connecting and disconnecting action.
- No check valve provided in a socket. Do not supply pressure when coupler disconnected state.
- Make sure air bleeding in the hydraulic circuit is perfectly done when installation.
- Reactive force generates when primary pressure is supplied. Locking device which exerts bigger force than reactive force should be mounted after couplers are connected.

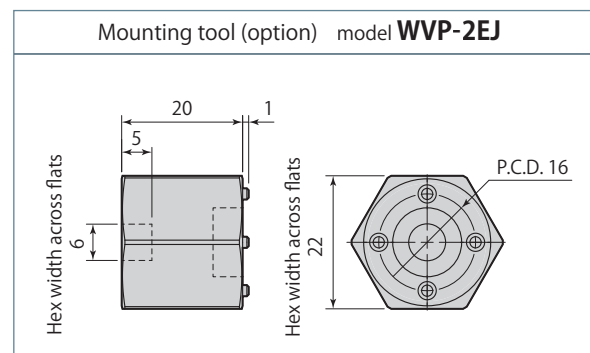

Clamp pressure holding action

- ① Disconnected state
- ② Connecting
- ③ Build pressure-1
- ④ Build pressure-2

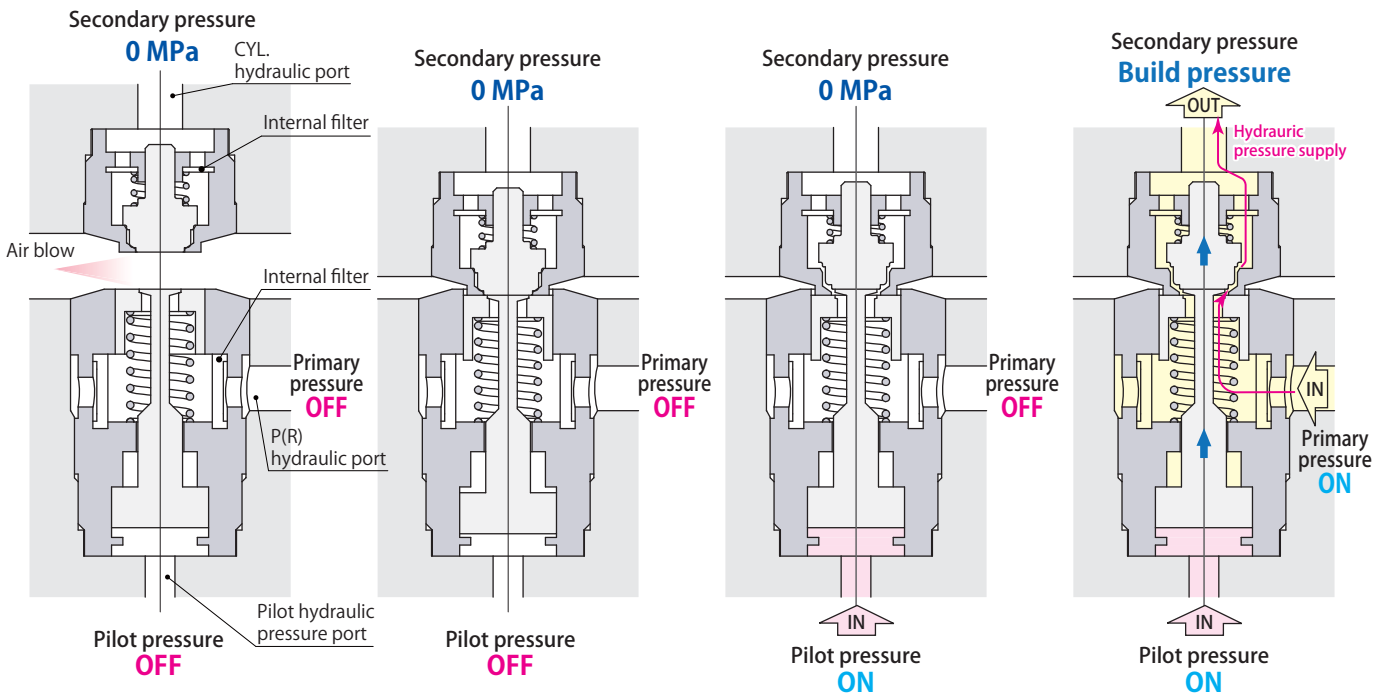

Do not supply primary and pilot pressure when coupler disconnected state.

Connect the couplers.

Supply pilot pressure to open the check valve.

Supply primary pressure after pilot pressure is supplied.

Clamp pressure release action

- ① Disconnected state
- ② Connecting
- ③ Clamp pressure release action-1

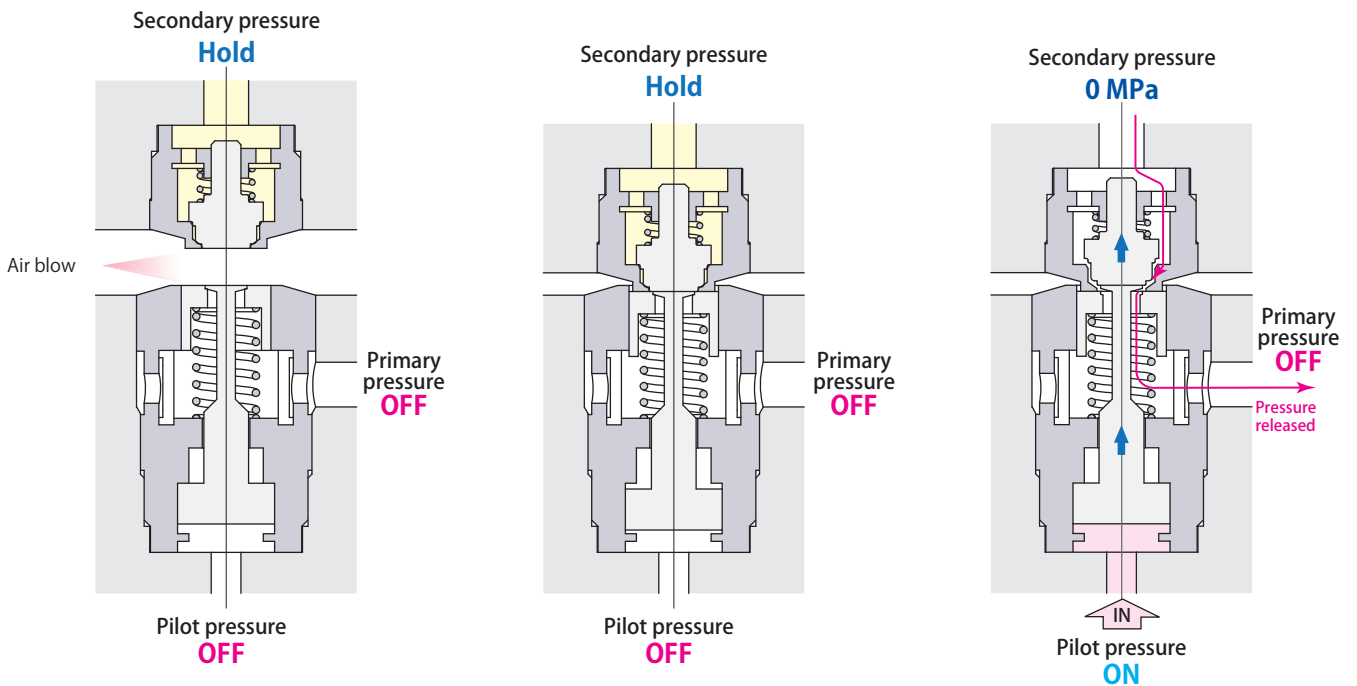

Do not supply primary and pilot pressure when coupler disconnected state.

Connect the couplers.

Supply pilot pressure after connection and release the clamp pressure.

Pilot coupler

WVP Oil

⑤ Pressure holding action-1

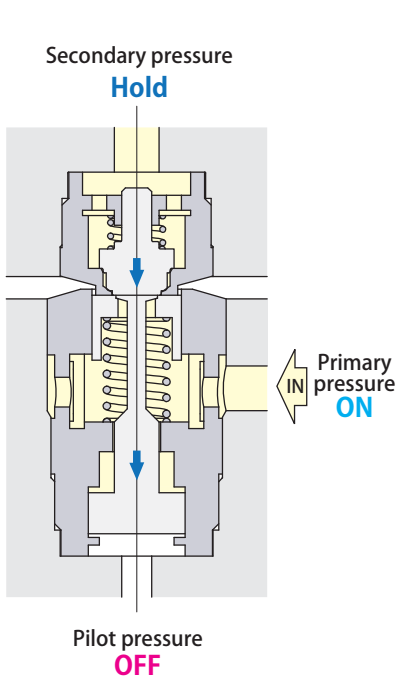

Stop supplying pilot pressure after secondary pressure is built up.

⑥ Pressure holding action-2

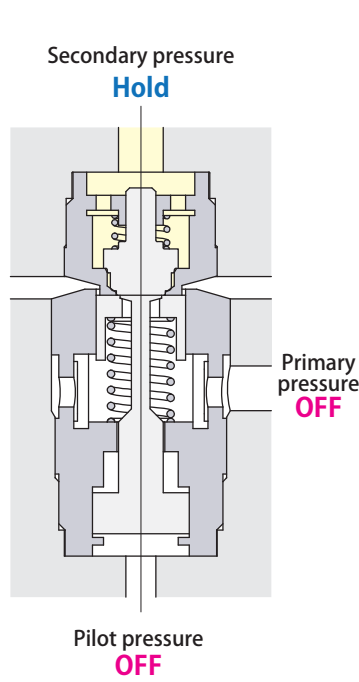

Stop supplying primary pressure after pilot pressure is supplied.

⑦ Coupler disconnecting action

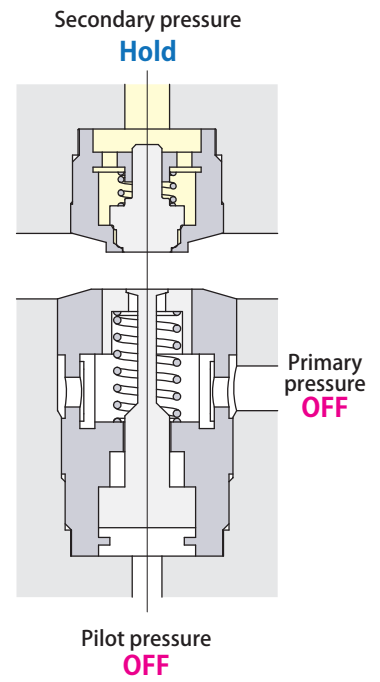

Clamp pressure is kept even after coupler is disconnected.

④ Clamp pressure release action-2

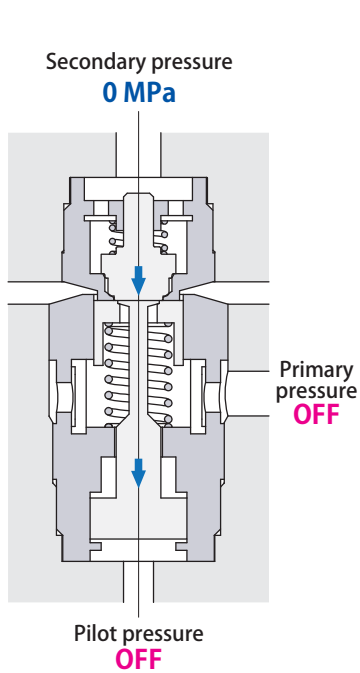

Stop supplying pilot pressure after clamp pressure is released.

⑤ Coupler disconnecting action

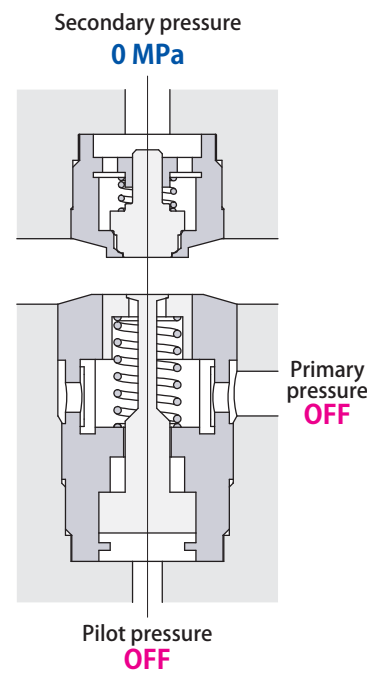

Disconnect couplers.

Caution in use

- Install the stopper to have the dimension $51.5_{-0.5}^0$ (See diagram on the below).
Observe allowable eccentricity and inclination value when installing the guide (Refer to **page →94**).

- Prepare a spacer block (by customer) separately when coupler is used with a pallet clamp.

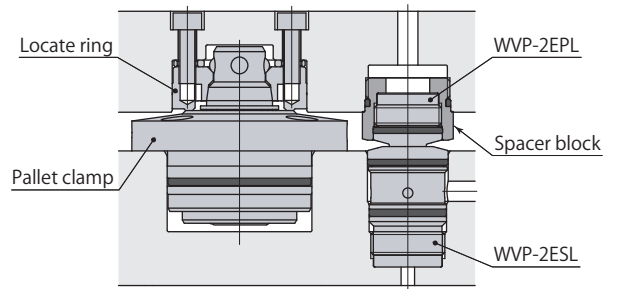
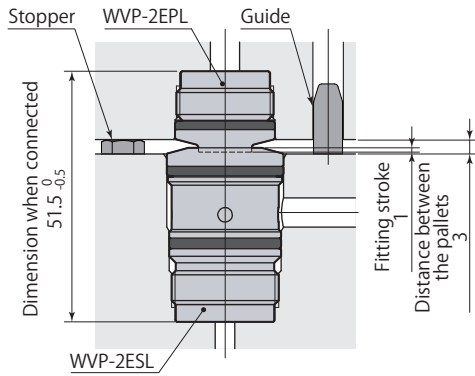

Hydraulic circuit diagram for double acting clamp

Hydraulic circuit diagram for single acting clamp

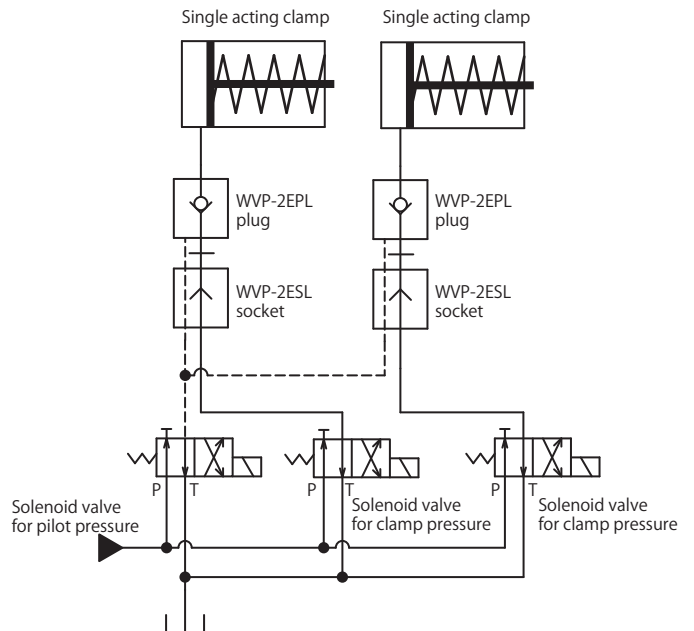
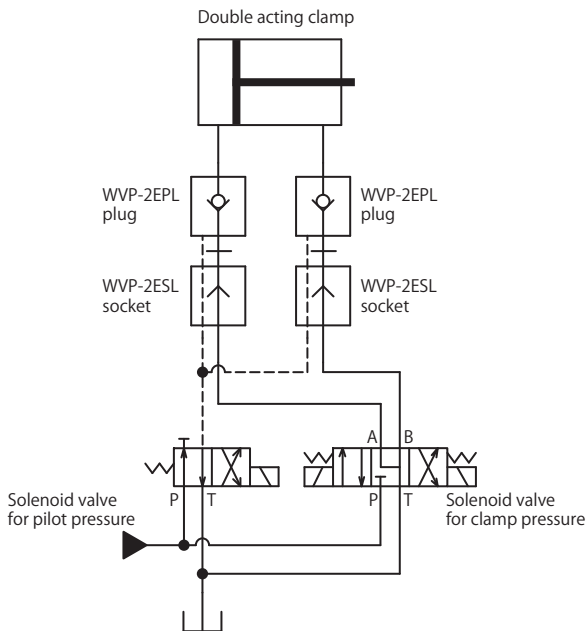

- 3 position, center tank-port solenoid valve should be used for clamp pressure circuit to avoid back pressure. A solenoid valve which switches to Tank port connection except supplying pressure to the circuit should be used.

- A solenoid valve which switches to Tank port connection except supplying pressure to the circuit should be used to avoid back pressure.

Caution in use

- Perform complete air bleeding of the circuit when using couplers under pressure type. Insufficient air bleeding may cause the oil spill when connecting or circuit pressure drop.
- Do not connect the couplers with metal chips or coolant on the tip of it. Perform air blow to clean it off if there is a risk of adherence.
- Provide complete flushing to the oil pass of the manifold block to avoid contamination of the burrs or debris in the circuit. Failure of this instruction may cause damage of seals and result in the oil leakage because all models of coupler does not have preventive filters to protect contamination from oil supply side.
- Set coupling force to be same or more than reactive force of each model. Reactive force remains active until coupler has been totally disconnected.
- Provide the guide pin separately because coupler does not contain a guide or stopper block.
- Do not mount the couplers on the place where coolant oil builds up.

Reactive force calculation example

Piping specification

Hydraulic pressure	Two double acting clamp circuits (5 MPa each) Coupler models : WVP-2BPH×2, WVP-2BSH×2
Air	One seating detection circuit (0.3 MPa) Coupler models : WVP-3DPN, WVP-3DSN

Reactive force against clamping

Clamping circuit

Spring force 40 (N) + Hydraulic pressure 5 (MPa) × 113 = 605 (N)

Unclamping circuit

Spring force 40 (N)

Air circuit

Spring force 60 (N) + Air pressure 0.3 (MPa) × 380 = 174 (N)

Total reactive force



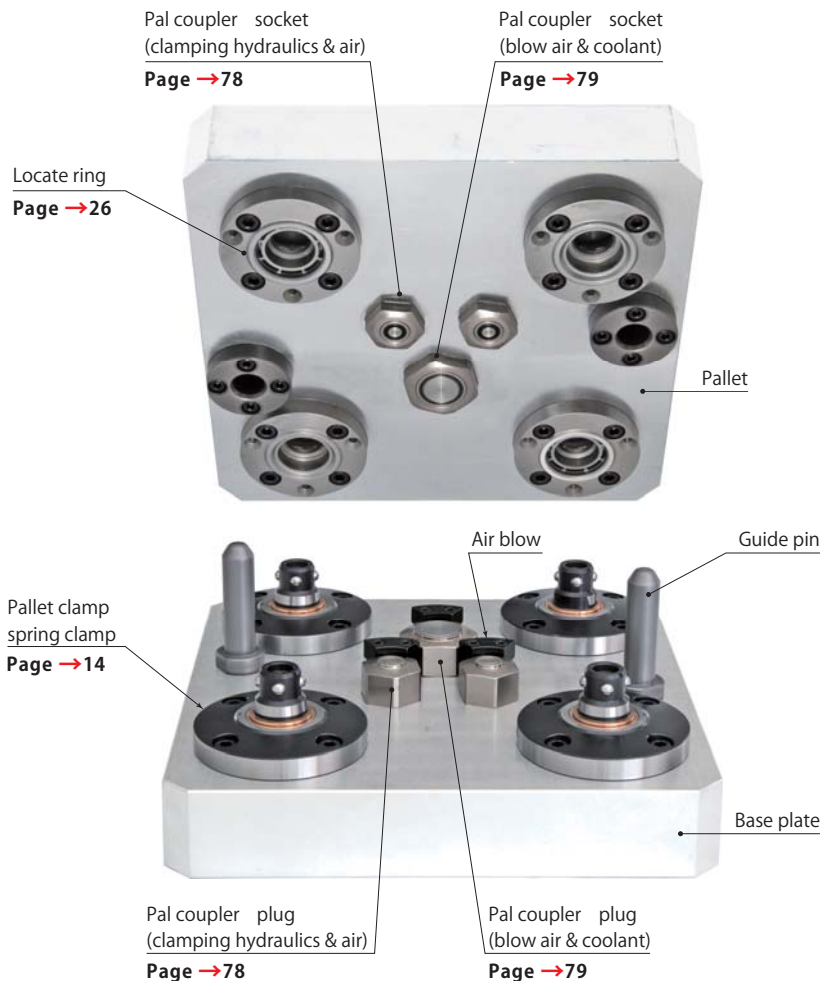







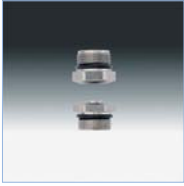



Hydraulic coupler 605 (N) + 40 (N) + Air coupler 174 (N) = 819 (N)



Standard Pal system configuration example

Coupler

WVP

<p>25MPa Pal coupler</p>  <p>Fluid used Oil, air Orifice 10.2 mm² Built in filter Not included Connect/disconnect under pressure Incapable</p> <p>Socket model WVP-2BSH Plug model WVP-2BPH</p> <p>Page →78</p>	<p>1MPa Pal coupler</p>  <p>Fluid used Air, coolant Orifice 29.0 mm² Built in filter Not included Connect/disconnect under pressure Incapable</p> <p>Socket model WVP-3DSN Plug model WVP-3DPN</p> <p>Page →79</p>	<p>7MPa Pal coupler</p>  <p>Fluid used Oil, air Orifice 10.2 mm² Built in filter Not included Connect/disconnect under pressure Incapable</p> <p>Socket model WVP-2FSL Plug model WVP-2FPL</p> <p>Page →84</p>	<p>1MPa Pal coupler</p>  <p>Fluid used Air, coolant Orifice 29.0 mm² Built in filter Not included Connect/disconnect under pressure Incapable</p> <p>Socket model WVP-3GSN Plug model WVP-3GPN</p> <p>Page →86</p>
<p>1MPa Pal coupler</p>  <p>Fluid used Air Orifice 8 mm² Built in filter Not included Connect/disconnect under pressure Incapable</p> <p>Socket model WVP-1FSN Plug model WVP-1FPN</p> <p>Page →88</p>	<p>7MPa Non-leak coupler Plug hydraulic pressure source</p>  <p>Fluid used Oil Orifice 12.5 mm² Built in filter Included Connect/disconnect under pressure Capable</p> <p>Socket (fixed) model WVP-2HSL Plug (fixed) model WVP-2HPL Plug (floating) model WVP-2HDL</p> <p>Page →90</p>	<p>7MPa Non-leak coupler Socket hydraulic pressure source</p>  <p>Fluid used Oil Orifice 12.5 mm² Built in filter Included Connect/disconnect under pressure Capable</p> <p>Socket model WVP-2SSL Plug model WVP-2SPL</p> <p>Page →92</p>	<p>7MPa Pilot coupler</p>  <p>Fluid used Oil Orifice 10.2 mm² Built in filter Included Connect/disconnect under pressure Incapable*</p> <p>*:Secondary pressure retainable</p> <p>Socket model WVP-2ESL Plug model WVP-2EPL</p> <p>Page →94</p>
<p>35MPa Non-leak coupler Plug hydraulic pressure source</p>  <p>Fluid used Oil Orifice 12.5 mm² Built in filter Included Connect/disconnect under pressure Capable</p> <p>Socket (fixed) model WVP-2HSH Plug (fixed) model WVP-2HPH Plug (floating) model WVP-2HDH</p> <p>Request a catalog separately.</p>	<p>35MPa Non-leak coupler Socket hydraulic pressure source</p>  <p>Fluid used Oil Orifice 12.5 mm² Built in filter Included Connect/disconnect under pressure Capable</p> <p>Socket model WVP-2SSH Plug model WVP-2SPH</p> <p>Request a catalog separately.</p>	<p>1MPa Air coupler</p>  <p>Fluid used Air Orifice 16.7 mm² Built in filter Included Connect/disconnect under pressure Incapable</p> <p>Socket model WVP-2WSN Plug model WVP-2WPN</p> <p>Request a catalog separately.</p>	<p>1MPa Coolant coupler</p>  <p>Fluid used Coolant Orifice 54.5 mm² Built in filter Not included Connect/disconnect under pressure Incapable</p> <p>Socket model WVP-4KSN Plug model WVP-4KPN</p> <p>Request a catalog separately.</p>
<p>7MPa Compact coupler</p>  <p>Fluid used Oil, air Orifice 12.5 mm² Built in filter Included Connect/disconnect under pressure Incapable</p> <p>Socket (fixed) model WVP-2CSL Socket (embedded) model WVP-2CFL Plug (fixed) model WVP-2CPL</p> <p>Request a catalog separately.</p>	<p>7MPa Pal coupler</p>  <p>Fluid used Oil, air Orifice 12.6 mm² Built in filter Not included Connect/disconnect under pressure Incapable</p> <p>Socket model WVP-2MSH Plug model WVP-2MDL</p> <p>Request a catalog separately.</p>	<p>25MPa Mini coupler</p>  <p>Fluid used Oil, air Orifice 12.6 mm² Built in filter Not included Connect/disconnect under pressure Incapable</p> <p>Socket model WVP-2MSH Plug model WVP-2MPH</p> <p>Request a catalog separately.</p>	