



Model designation

HCS D - H **G2** **S** **S** **S** - **U**

Control voltage DC24V

\* In case of other solenoid valve voltage, contact Pascal separately.  
In case of AC voltage, CE and UL standard are not applicable.

- 1 Pascal pump
- 2 Hydraulic circuit
- 3 Hydraulic gauge for each circuit

Hydraulic pressure circuit

XXX circuit

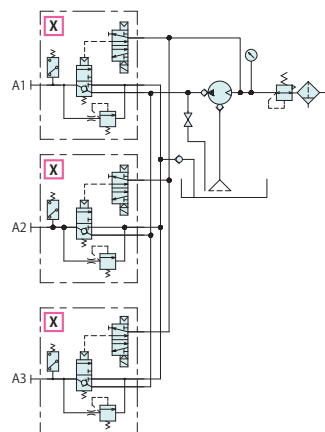

Hydraulic pressure circuit

SSS circuit

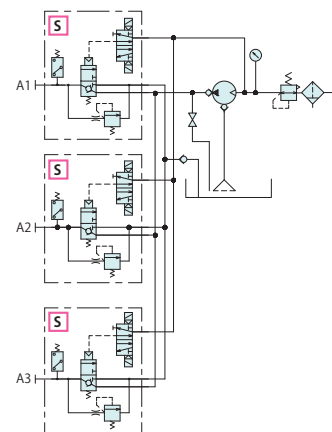

1 Pascal pump (model × quantity)

For use of mineral oil, contact Pascal separately.

**G2** : X6308UG × 1unit

2 Hydraulic circuit

Number of clamp circuit		Pascal pump model × quantity	Control unit model	
Fixed side	Movable side		Single solenoid valve	Double solenoid valve
	1	X6308UG × 1unit	X	S
1	1	X6308UG × 1unit	XX	SS
1	2	X6308UG × 1unit	XXX	SSS
2	2	X6308UG × 1unit	XXXX	SSSS

Clamp circuit Single solenoid valve + relief valve : X Double solenoid valve + relief valve : S

3 With hydraulic gauge for each circuit

: Without

: With

Specifications

Model	HCS D-HG2□-□	
Pump model × quantity	X6308UG × 1unit	
Valve switching system	Pilot air	
Discharge pressure	MPa	24.5
Driving air pressure	MPa	0.47
Discharge volume (at no load)	L/min	1.3
Oil tank capacity	L	LOW-LEVEL : 1.5 / UPPER : 3.5
Set pressure of pressure switch	MPa	14.7 (INC.)
Set pressure of relief valve	MPa	27.9
Air consumption rate	Nm <sup>3</sup> /min	Max. 0.4
Operating temperature	°C	5 ~ 50

● Fluid : water glycol system working oil

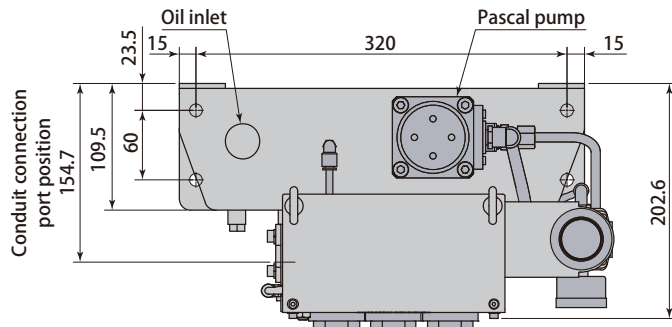

● The drawings showing : HCS-D-HG2SSS.  
For 4 circuits application, contact Pascal for details.

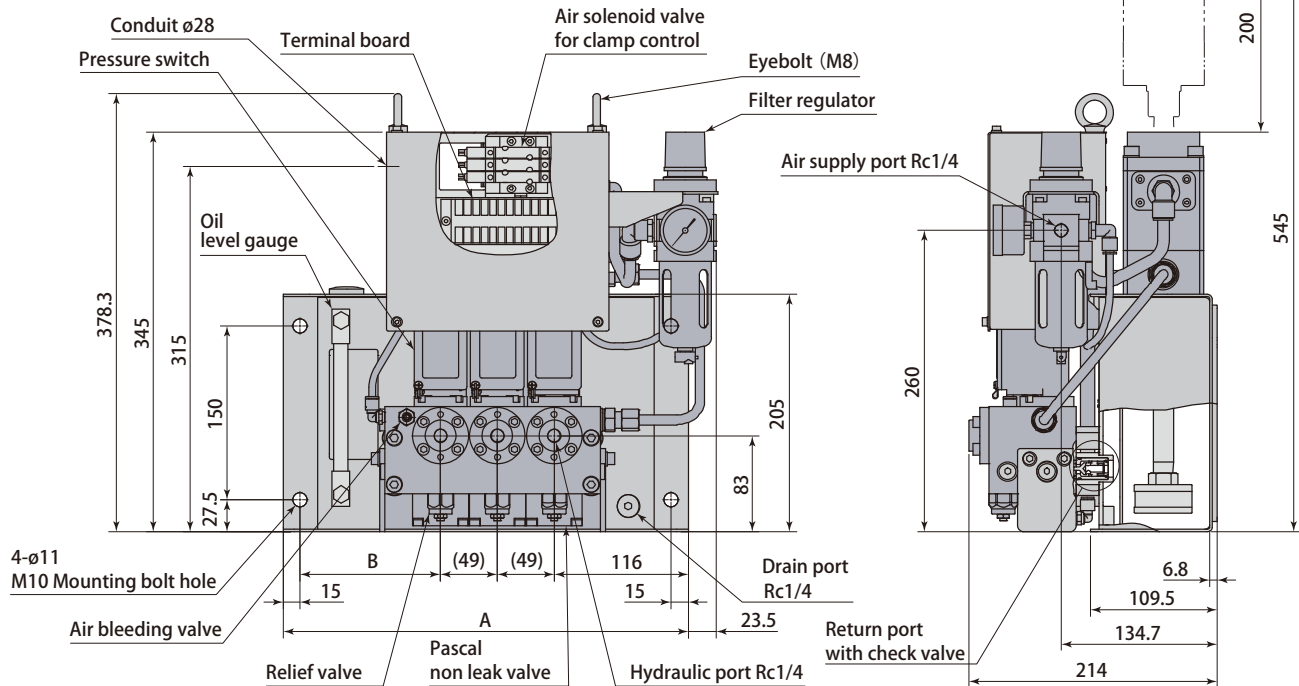

Control unit  
HCS

Number of hydraulic circuit		1	2	3	4
<b>A</b>	mm	350	350	350	400
<b>B</b>	mm	234	185	136	137
<b>Weight</b>	kg	18	21	24	27

- Model HCL should be chosen in case of the following cases.
1. Double pump type is required.
  2. The signal of abnormal high pressure is required for interlocking.
  3. More than five circuits of hydraulic valve are required.

**Anti vibration rubber (option)**

model ZPS-B5

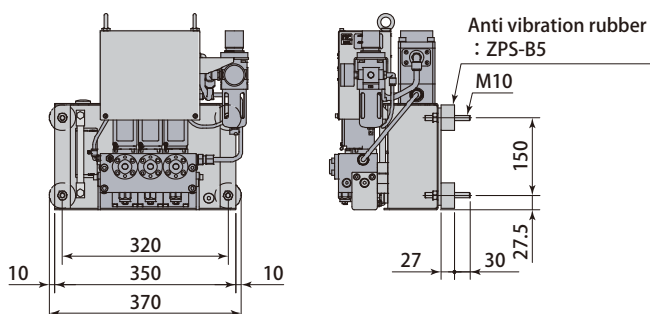

**Stand (option)**

model ZPS-S0

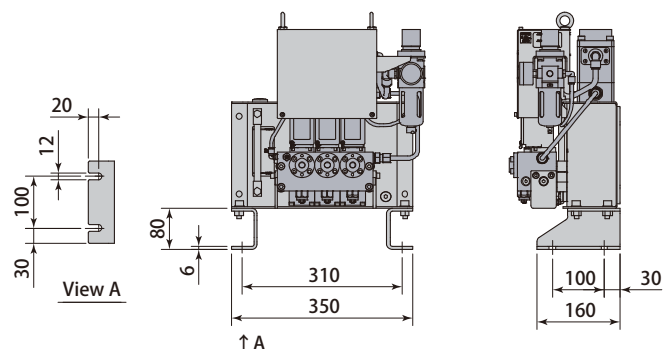



Model designation

HCL D - H G2 S S S - L

Control voltage DC24V

\* It can not correspond to voltage other than DC24 V.

- 1 Pascal pump
- 2 Hydraulic circuit  
\* Indicated in 3-4 alphabets.
- 3 Special specification

Hydraulic and air pressure circuit  
XXX circuit

XXX circuit

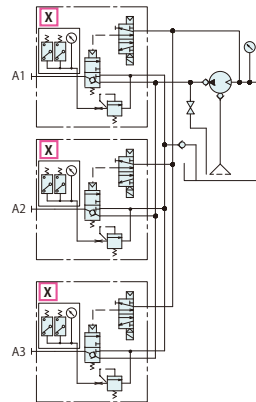

Hydraulic and air pressure circuit  
SSS circuit

SSS circuit

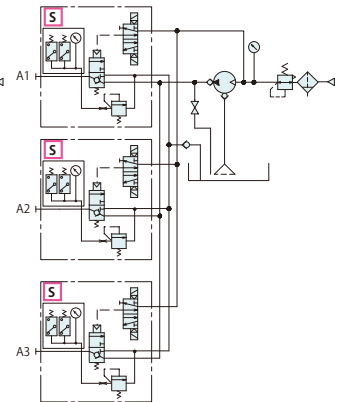

1 Pascal pump (model × quantity)

For use of mineral oil, contact Pascal separately.

G2 : X6308UG × 1unit

G22 : X6308UG × 2units

3 Special specification

∅ : Without

L : Low oil level detection switch

T2 : 2-position double air solenoid valve equipped × 2  
(for vertical clamp slider and die positioning pin)

T3 : 3-position center exhaust air solenoid valve equipped × 2  
(for horizontal clamp slider)

2 Hydraulic circuit

Number of clamp circuit		Pascal pump model × quantity	Control unit model	
Fixed side	Movable side		Single solenoid valve	Double solenoid valve
1	2	X6308UG × 1unit	XXX	SSS
2	2	X6308UG × 1unit	XXXX	SSSS
1	2	X6308UG × 2units	XXX	SSS
2	2	X6308UG × 2units	XXXX	SSSS

Clamp circuit Single solenoid valve + relief valve : X Double solenoid valve + relief valve : S

Specifications

Model	HCLD-HG2□-□	HCLD-HG22□-□
Pump model × quantity	X6308UG × 1unit	X6308UG × 2units
Valve switching system	Air pilot system	
Discharge pressure	MPa	24.5
Driving air pressure	MPa	0.47
Discharge volume (at no load)	L/min	1.3
Oil tank capacity	L	LOW-LEVEL : 1.5 / UPPER : 3.5
Set pressure of digital pressure gauge	MPa	14.7 / 30.8 (at excessively high pressure)
Set pressure of relief valve	MPa	27.9
Air consumption rate	Nm <sup>3</sup> /min	Max. 0.4
Operating temperature	°C	5 ~ 50

● Fluid : water glycol system working oil

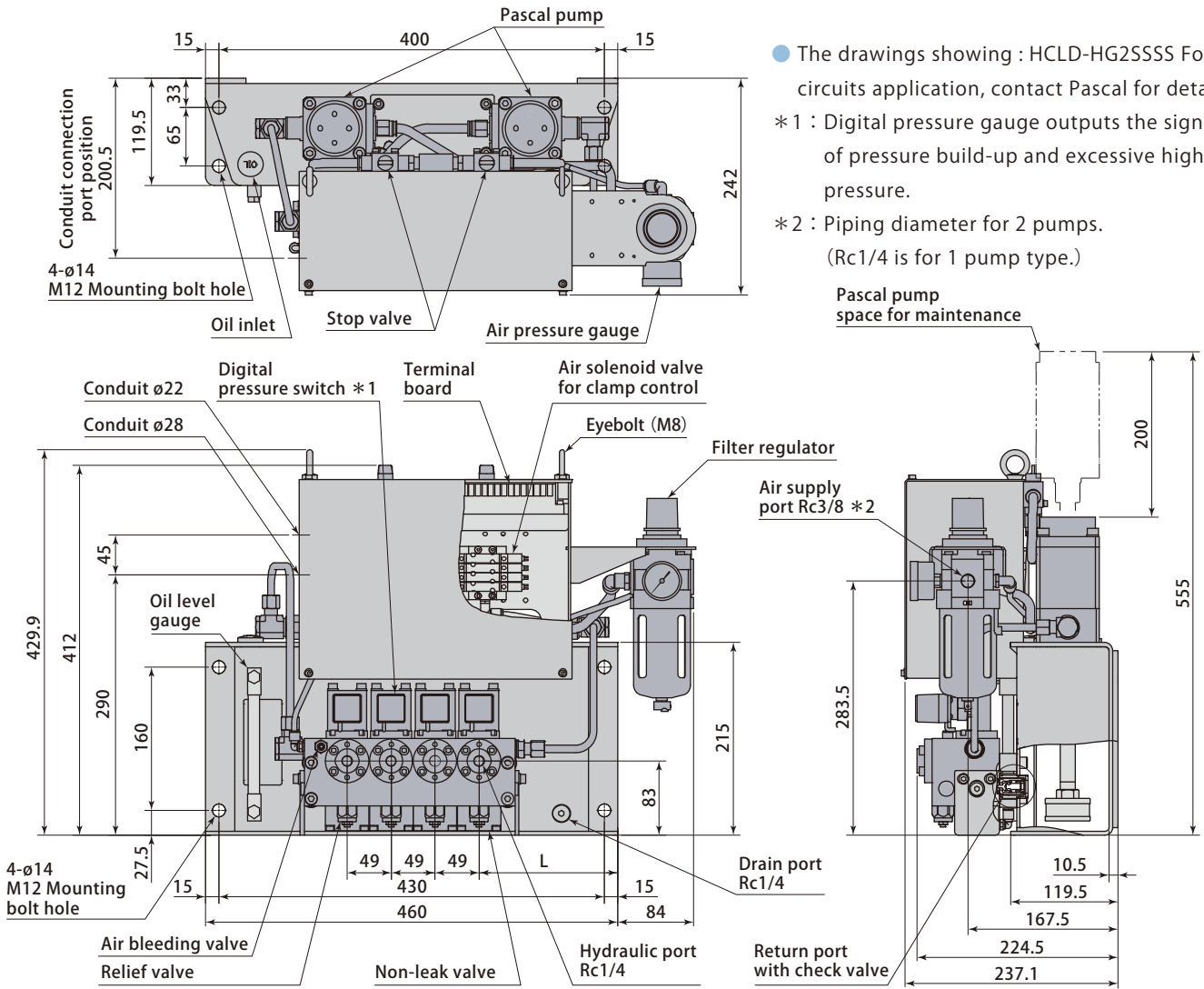

- The drawings showing : HCLD-HG2SSSS For 5 circuits application, contact Pascal for details.
- \*1 : Digital pressure gauge outputs the signal of pressure build-up and excessive high pressure.
- \*2 : Piping diameter for 2 pumps. (Rc1/4 is for 1 pump type.)

Number of hydraulic circuit		1	2	3	4
L	mm	204	179.5	155	155
Weight	kg	26	29	32	34

● Weight for 1 unit of pump (dried) . 3kg to be added when 2 pumps are applied.

Anti vibration rubber (option)  
model ZPS-B6

Stand (option)  
model ZPS-S4

Stand (option)  
model ZPS-PZXA7320

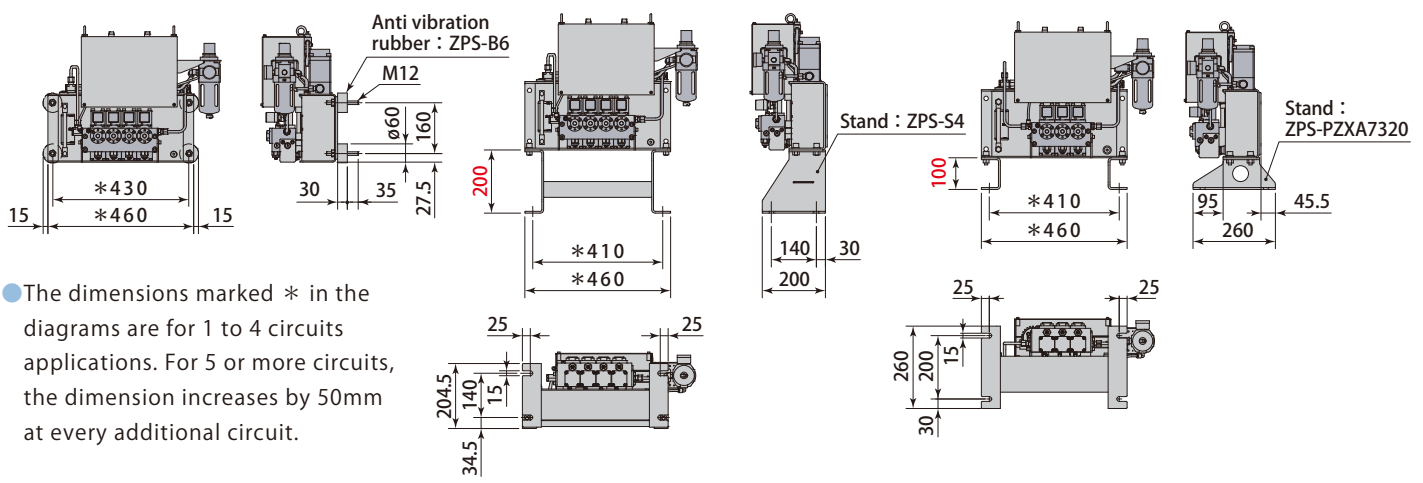

● The dimensions marked \* in the diagrams are for 1 to 4 circuits applications. For 5 or more circuits, the dimension increases by 50mm at every additional circuit.